



# Air-Cooled Condensers

---

20 to 120Tons





## Introduction

---

# Air-Cooled Condensers Built for Every Need

**Trane has the right condenser...** If you are designing a new system or replacing an existing air-cooled condenser, Trane can satisfy virtually any application need. Whether coupled with an industrial compressor, a single zone commercial self-contained unit, compressor chiller or a Cold Generator® chiller, Trane has the right air-cooled condenser for the job. When teamed with any one of a

wide range of compressor-evaporator combinations, Trane air-cooled condensers, available in 20 to 120 tons, are ideal for multistory office buildings, hotels, schools, municipal and industrial facilities.



# Contents

---

<b>Introduction</b>	2
<b>Features and Benefits</b>	4
<b>Application Considerations</b>	5
<b>Selection Procedure</b>	6
Model Number Description	8
<b>General Data</b>	9
<b>Performance Data</b>	11
Performance Adjustment Factors	10
<b>Electric Power</b>	12
<b>Dimension and Weights</b>	13
<b>Mechanical Specifications</b>	23



# Features and Benefits

---

## 20 to 120 Ton Units

Trane 20 to 120 ton air-cooled condensers have an operating range of 40 F to 115 F, with a low ambient option down to 0 F.

The control panel is factory-installed and wired to prevent potential damage and to provide weathertight protection.

The control panel contains:

- fan motor contactors.
- fan cycling controls.
- terminal point connection for compressor interlock.
- 115-volt control power transformer.

These standard features reduce installation costs and provide easy interface with control logic.

All Trane air-cooled condenser coils are tube-in-sheet construction with copper tubing mechanically bonded to configurated aluminum fins. 20 to 30 ton condensers are single circuit; 40 to 120 ton units are dual circuited; all feature integral subcooling.

Copper coils are optional.

## Durable Construction

Trane 20 to 120 ton condensers are built for long life. The unit frame is constructed of 14 gauge galvanized steel. Louvered panels provide excellent coil protection while enhancing unit appearance and strength. The unit surface is phosphatized and finished with Trane Slate Grey air-dry paint. This air dry-paint finish exceeds 500 consecutive hour salt spray resistance in accordance with ASTM B117.

# Application Considerations

Certain application constraints should be considered when sizing, selecting, and installing air-cooled condensers. Unit and system reliability depends on properly and completely acknowledging these considerations. Consult your local Trane sales engineer if your application varies from these guidelines.

## Setting the Unit

A base or foundation is not required if the selected unit location is level and strong enough to support the operating weight. Refer to the Weights section for the weight of individual units.

## Isolation and Sound Emission

The most effective method of noise isolation is proper unit location. Units should be placed away from noise sensitive areas. Structurally transmitted noise can be reduced with the use of spring isolators and they are recommended for acoustically sensitive applications. Flexible electrical conduit, for maximum isolation effectiveness, will

reduce sound transmitted through electrical conduit.

State and local codes on sound emissions should always be considered. Since the environment in which a sound source is located affects sound pressure, unit placement must be carefully evaluated.

## Servicing

Recommended minimum space envelopes for servicing are located in the Dimensional Data section and serve as guidelines for providing adequate clearance. The minimum space envelopes also allow for control panel door swing and routine maintenance requirements.



# Application Considerations

## Unit Location

Unobstructed flow of condenser air is essential to maintaining capacity and operating efficiency. When determining unit placement, careful consideration must be given to assure a sufficient flow of air across the condenser heat transfer surface. Two detrimental conditions are possible and must be avoided: Warm air recirculation and coil starvation.

Warm air recirculation occurs when discharge air from the condenser fans is recycled back at the condenser coil inlet. Coil starvation occurs when free airflow to the condenser is restricted.

Both warm air recirculation and coil starvation cause reductions in unit efficiency and capacity because of the higher head pressures associated with them. In more severe cases, nuisance unit shutdowns will result from excessive head pressures.

Cross winds, those perpendicular to the condenser, tend to aid efficient operation in warmer ambient conditions. However, they tend to be detrimental to operation in lower ambients or when hot gas bypass is used due to the accompanying loss of adequate head pressure. As a result, it is advisable to protect air-cooled condensers from continuous direct winds exceeding 10 miles per hour.

Debris, trash, supplies, etc., should not be allowed to accumulate in the vicinity of the air-cooled condenser. Supply air movement may draw debris into the condenser coil, blocking spaces between coil fins and causing coil starvation. Special consideration should be given to low ambient units. Condenser coils and fan discharge must be kept free of snow or other obstructions to permit adequate airflow for satisfactory unit operation.

## Clearance

Vertical condenser air discharge must be unobstructed. While it is difficult to predict the degree of warm air recirculation, a unit installed with a ceiling or other obstruction above it will lose capacity and the maximum ambient operation will be reduced. Nuisance high head pressure tripouts may also occur.

The inlet to the coil must also be unobstructed. A unit installed closer than the minimum recommended distance to a wall or other vertical riser may experience a combination of coil starvation and warm air recirculation, resulting in unit capacity and efficiency reductions, as well as possible excessive head pressures. The recommended lateral distances are listed in the Dimensional Data section.

## Voltage

Nominal voltage is the nameplate rating voltage. The actual range of line voltages at which the equipment can satisfactorily operate is given below:

Nominal Voltage	Voltage Utilization Range
200/220	180-220 or 208-254
460	416-508
575	520-635

200/230-volt units ship from the factory set for operation in the 180 through 220-volt range. By changing leads on unit transformers, the unit will operate in the 208 through 254-volt range.

## Effects of Altitude

The tables in the Performance Data section are for use at sea level. At elevations substantially above sea level, the decreased air density will decrease condenser capacity. Refer to the Performance Adjustment Factors section to correct performance at other altitudes.

## Ambient Limitations

Trane condensers are designed for year-around applications in ambients from 0 F through 115 F. For operation below 0 F or above 115 F, contact the local Trane sales office.

Start-up and operation of Trane condensers at lower ambient temperatures require that sufficient head pressure be maintained for proper operation. Minimum operating ambient temperatures for standard unit selections and units with hot gas bypass are shown in the General Data section. These temperatures are based on still conditions (winds not exceeding five mph.) Greater wind velocities will result in a drop in head pressure, therefore, increasing the minimum starting and operating ambient temperatures.

Units with the low ambient option are capable of starting and operating in ambients down to 0 F, 10 F with hot gas bypass. Optional low ambient units use a condenser fan damper arrangement that controls condenser capacity by modulating in response to head pressure.

Maximum cataloged ambient temperature operation of a standard condenser is 115 F. Operation at design ambients above 115 F can result in excessive head pressures. For operation above 115 F, contact the local Trane sales office.



# Selection Procedures

When selecting a combination of equipment, it becomes necessary to match the compressor and condenser performance. The following procedure should be used in determining the correct condenser.

**First:**

Determine the total cooling load and the evaporator sst and compressor required.

**Example:**

- Given - Total cooling load = **96 tons**
- Ambient temp = **95 F**
- Evaporator sst = **45 F**
- Compressor - **CUAB-D10E**

The compressor was selected from **COM-DS-1** catalog according to the sst and maximum acceptable condensing temperature for adequate compressor capacity.

**a**

Plot at least two gross compressor capacities (less subcooling) at the design suction temperature and different condensing temperatures. (subcooling factor is .047% per deg. F subcooling, **16 F** for **CUAB-D10E**)

**Example:**

(From **COM-DS-1**)

**CUAB-D10E** Compressor at **45 F** sst.

With:

**115 F** condensing temperature = 113.5 tons divided by 1.075 subcooling factor = **105.6** tons.

With:

**125 F** condensing temperature = 105.1 tons divided by 1.075 subcooling factor = **97.8** tons

**b**

Plot two gross condenser heat rejection points on chart PD-1 divided by the compressor **N** factor (Table PD-1 to PD-3) at different condensing temperatures.

**Example: Anticipating 100 ton condenser to meet design load of 96 tons.**

Cond. Temp	ITD		Gross Heat of Rejection (MBh)	=	Tons	÷	N Factor	=	Tons
115	at 20	=	830	=	69.2	÷	1.25*	=	55.4
125	at 30	=	1285	=	107.1	÷	1.30*	=	82.3

\*N factor corrected from Table PD-2  
 sst - saturated suction temperature  
 F - degree Fahrenheit  
 N - compressor factor  
 ITD - initial temperature difference

**c**

Transfer the results from the compressor and condenser plots to Chart SP-1 and do the following. Draw a line through the two points representing gross heat compressor capacities less subcooling (**105.6** and **82.3**). Draw a line through the two points representing condenser gross heat of rejection (**55.4** and **82.3**).

**d**

At the point of intersection of the compressor and condenser lines draw dashed lines to the left and bottom margins of Chart SP-1. The end points of these lines will show a resultant gross condenser capacity of **93.8** tons at **129.4 F** condensing temperature.

**e**

From chart PD-2 calculate the percent increase in capacity due to subcooling.

**Example:**

At **95 F** ambient and **129.4 F** condensing temperature there is a **10.1%** increase in capacity due to subcooling. This yields a system net capacity of **93.8** tons x **110%** = **103.2** tons.

**f**

If necessary use the values in Table PD-4 to adjust the system capacity for altitude.

**g**

Compare this result with the design capacity and condensing temperature.

The required cooling load is **96** tons, therefore, the **CAUC-D10** is the proper selection.

Repeat the process steps **B** through **G** as necessary to achieve the most economic condenser selection.

# Selection Example

Chart SP-1 - Selection Example

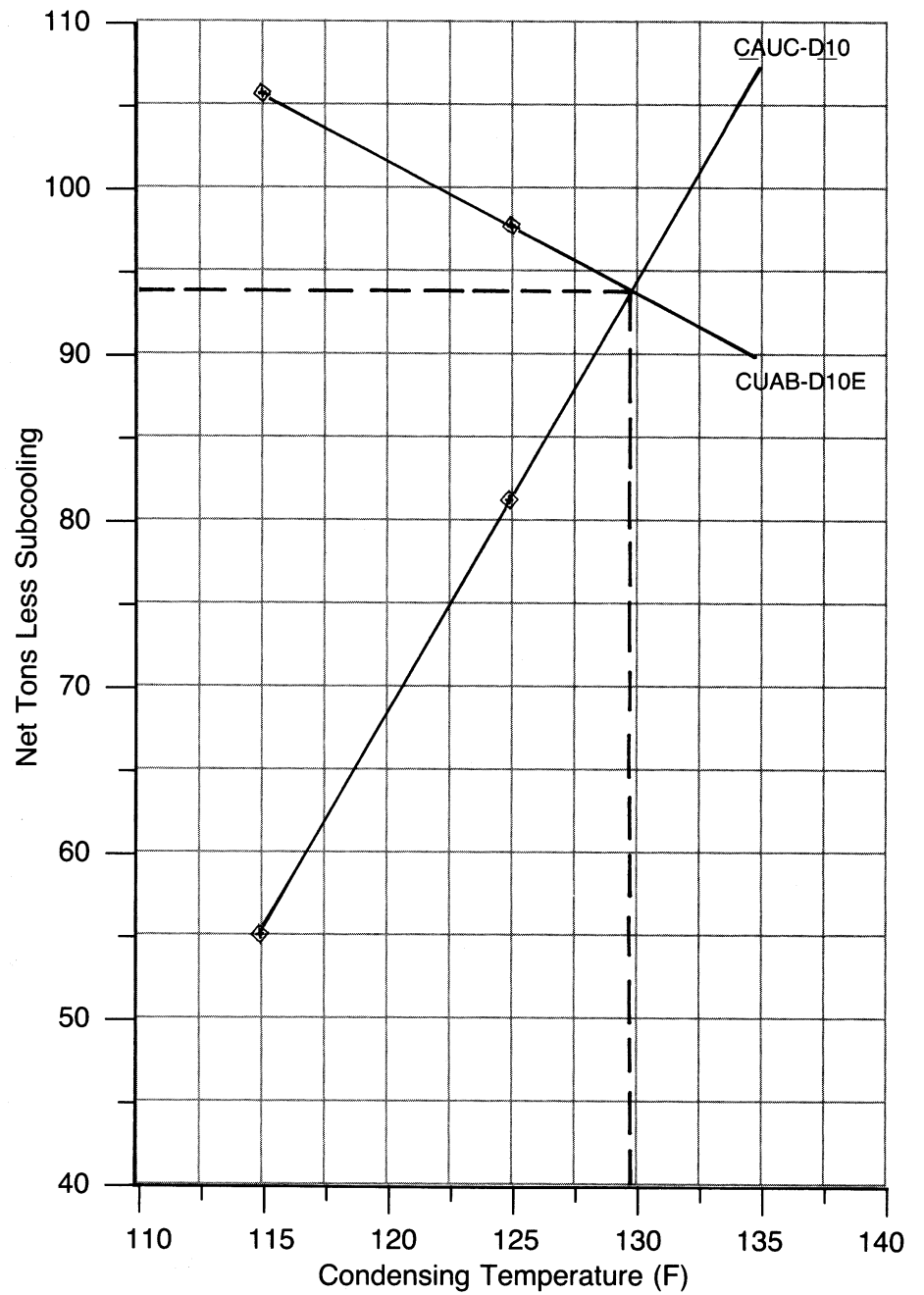



# Model Number Description

## 20To 60Ton Model Nomenclature

C A U C C20 4 1 \* 0 3 H 0<sup>1</sup>  
 1 2 3 4 5,6,7 8 9 10 11 12 13 14

**Digit 1 – Unit Type**

C = Condenser

**Digit 2 – Condenser**

A = Air-Cooled

**Digit 3 – Airflow**

U = Upflow

**Digit 4 – Development Sequence**

C = Third

**Digit s 5,6,7 – Nominal Capacity**

C20 = 20Tons      C40 = 40Tons  
 C25 = 25Tons      C50 = 50Tons  
 C30 = 30Tons      C60 = 60Tons

**Digit 8 – Power Supply**

G = 200/230/60/3 XL  
 4 = 460/60/3 XL  
 5 = 575/60/3 XL

**Digit 9 – Condenser Circuit**

1 = Single (20-30 Ton)  
 2 = Dual (40-60 Ton)

**Digit 10 – Design Sequence**

\* = Factory Assigned

**Digit 11 – Ambient Control**

0 = Standard  
 1 = 0 F

**Digit 12 – Agency Approval**

0 = None  
 3 = UL/CSA

**Digits 13, 14 – Miscellaneous**

H = Copper Fins  
 1 = Spring Isolators  
 2 = Rubber Isolators

## 80To 120Ton Model Nomenclature

C A U C C80 4 2 A 0 3 H 0<sup>1</sup>  
 1 2 3 4 5,6,7 8 9 10 11 12 13 14

**Digit 1 – Unit Type**

C = Condenser

**Digit 2 – Condenser**

A = Air-Cooled

**Digit 3 – Airflow**

U = Upflow

**Digit 4 – Development Sequence**

C = Third

**Digits 5,6,7 – Nominal Capacity**

C80 = 80 Tons  
 D10 = 100 Tons  
 D12 = 120 Tons

**Digit 8 – Power Supply**

F = 230/60/3  
 4 = 460/60/3  
 5 = 575/60/3  
 E = 200/60/3

**Digit 9 – Condenser Circuit**

2 = Dual Circuit

**Digit 10 – Design Sequence**

A = First

**Digit 11 – Ambient Control**

0 = Standard  
 1 = 0 F

**Digit 12 – Agency Approval**

0 = None  
 2 = CSA  
 3 = UL/CSA

**Digits 13, 14 – Miscellaneous**

H = Copper Fins  
 1 = Spring Isolators

1. The service digit for each model number contains 14 digits; all 14 digits must be referenced.



# General Data

**Table GD-1 – General Data**

	20Ton	25Ton	30Ton	40Ton	50Ton	60Ton	80Ton	100Ton	120Ton
<b>Model Number</b>	CAUC-C20	CAUC-C25	CAUC-C30	CAUC-C40	CAUC-C50	CAUC-C60	CAUC-C80	CAUC-D10	CAUC-D12
Gross Heat Rejection (MBh) <sup>1</sup>	301	373	455	614	712	888	1244	1425	1819
<b>Condenser Fan Data</b>									
Number/Size/Type	2/26"/Prop	3/26"/Prop	3/26"/Prop	4/26"/Prop	6/26"/Prop	6/26"/Prop	8/26"/Prop	12/26"/Prop	12/26"/Prop
Fan Drive	Direct	Direct	Direct	Direct	Direct	Direct	Direct	Direct	Direct
No. of Motors/Hp (Each)	2/1.0	3/1.0	3/1.0	4/1.0	6/1.0	6/1.0	8/1.0	12/1.0	12/1.0
Nominal Cfm	12,400	16,700	19,000	24,800	33,400	38,000	49,600	66,800	76,000
<b>Condenser Coil Data</b>									
No./Size (In.)	1/63x71	1/71x71	1/45x71 1/49x71	2/65x70	2/51x96	2/66x90	4/65x70	4/51x96	4/66x90
Face Area (Sq. Ft.)	31.0	35.0	46.1	63.2	67.1	88.0	126.4	136.0	165.0
Rows/Fins Per Ft.	3/168	3/156	3/168	3/168	3/156	3/168	3/168	3/156	3/168
<b>General Data</b>									
No. Refrigerant Circuits	1	1	1	2	2	2	2	2	2
Operating Charge <sup>2</sup> (Lbs of R-22)	25	28	37	52	56	74	104	112	148
Condenser Storage Capacity <sup>3</sup>	67	76	96	136	142	184	272	284	368
<b>Ambient Temperature Operating Range</b>									
Standard Ambient (F)	40-115	40-115	40-115	40-115	40-115	40-115	40-115	40-115	40-115
Low Ambient Option (F)	0-115	0-115	0-115	0-115	0-115	0-115	0-115	0-115	0-115

**Notes:**

- Gross Heat Rejection is at a 30 F ITD (Initial Temperature Difference) between condensing temperature and ambient air entering condenser (includes the effect of subcooling).
- Operating charge is for entire unit.
- At conditions of 95 F ambient, condenser is 95 percent full.



# Performance Adjustment Factors

Chart PD-2- Compressor-Condenser Capacity Increase Due To Subcooling (R-22)

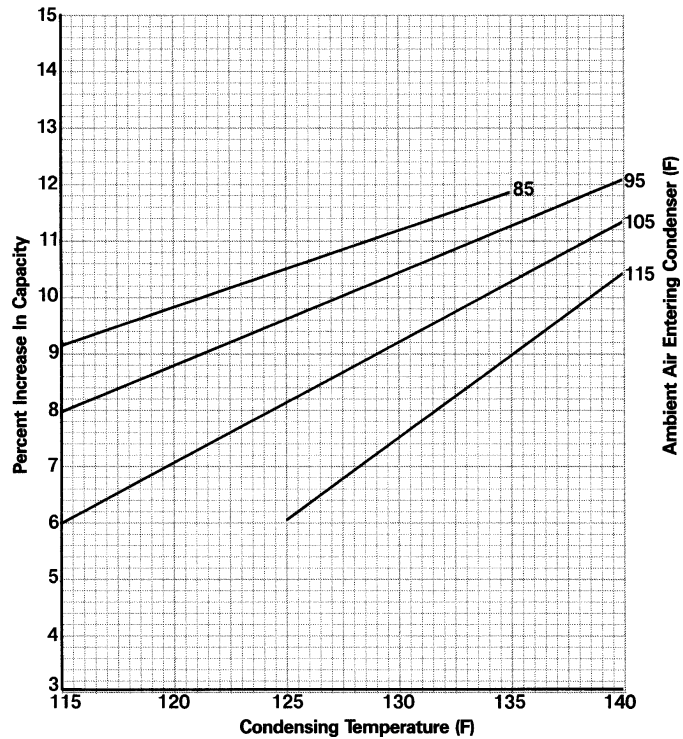

Table PD-1 - - N Factor - - Semihermetic Compressors

Cond. Temp.	Saturated Suction Temperature (F)				
	30	35	40	45	50
110	1.34	1.32	1.29	1.27	1.25
115	1.36	1.34	1.31	1.29	1.27
120	1.40	1.37	1.34	1.32	1.30
125	1.43	1.40	1.37	1.34	1.32
130	1.48	1.44	1.40	1.38	1.35
135	1.52	1.48	1.44	1.41	1.38
140	1.58	1.54	1.49	1.45	1.42
145	1.65	1.59	1.54	1.49	1.46

Note:

- In order to determine N factor for CUAB units, find proper factor corresponding with the proper suction and condensing temperature from Table 9-1. This factor should be adjusted by adding or subtracting the correction value from Table 9-2.

Table PD-2 - - N Factor - - Open Compressors

Cond. Temp.	Saturated Suction Temperature (F)				
	30	35	40	45	50
110	1.245	1.225	1.215	1.195	1.175
115	1.260	1.240	1.230	1.210	1.190
120	1.275	1.255	1.245	1.225	1.205
125	1.290	1.270	1.260	1.240	1.220
130	1.305	1.285	1.275	1.255	1.235
135	1.320	1.300	1.290	1.270	1.250
140	1.335	1.315	1.305	1.285	1.265

Table PD-4 - - N Factor Correction - - Compressor

Compressor	Correction Factor
CUAB-015M	+ 0.02
020M	---
025M	- 0.01
030M	+ 0.01
040R	- 0.02
050R	- 0.04
060R	- 0.04
075E	- 0.02
100E	- 0.04

Table PD-3 - - Altitude Correction Multiplier For Cooling Capacity - - Air-Cooled Condenser

Altitude (Ft)	2,000	4,000	6,000	8,000	10,000
Correction Multiplier	0.977	0.949	0.917	0.881	0.843

# Performance Data

Chart PD-1 – Condenser Heat Rejection (R-22), 20-120 Ton

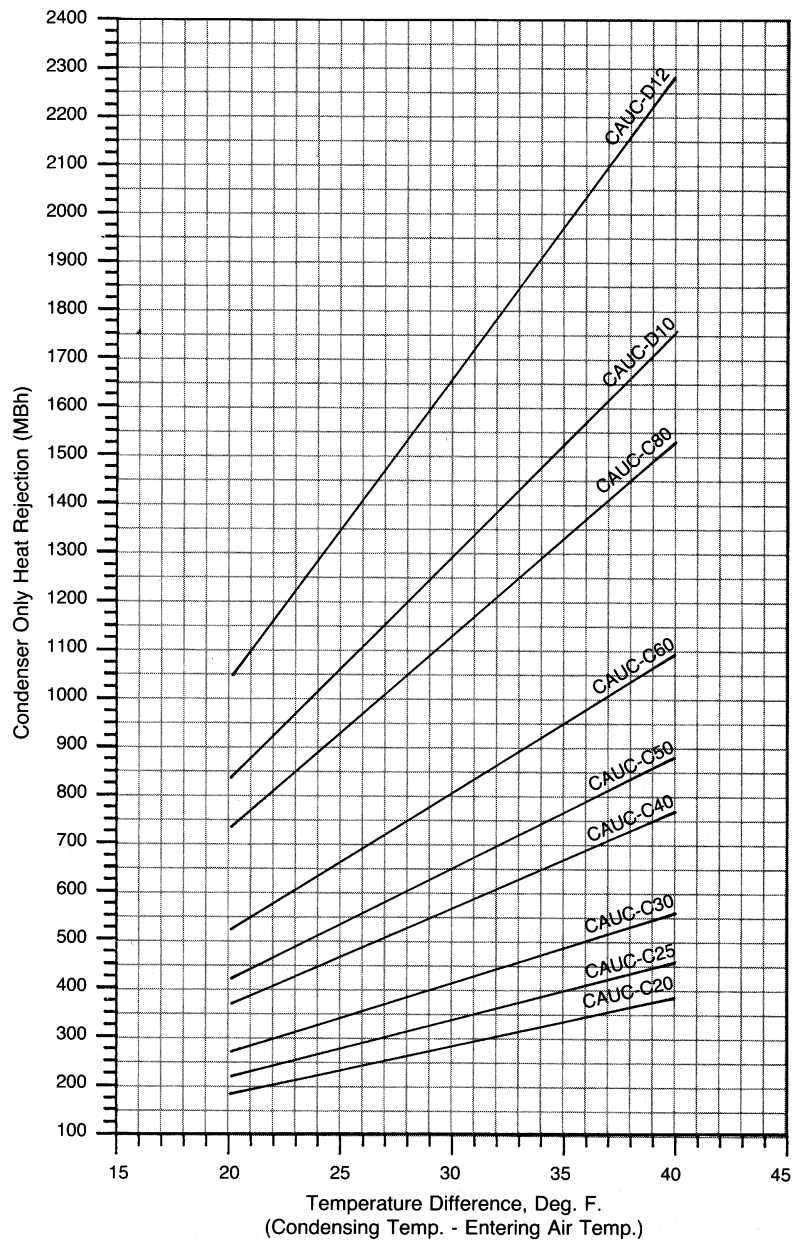



# Electrical Data

Table ED-1 — Electrical Data

Nominal Tons	Model No.	Unit Characteristics				Condenser Fan Motor			
		Electrical Characteristics	Allowable Voltage Range	Minimum Circuit Ampacity (3),(5)	Maximum Fuse Size (2),(5)	No./HP (1)	FLA (Ea.) (1)	LRA (Ea.) (1)	KW (Ea.) (1),(4)
20	CAUC-C20G	200-230/60/3	180-220/208-254	9.2	15	2/1.0	4.1	20.7	0.9
	CAUC-C204	460/60/3	416-508	4.1	15	2/1.0	1.8	9.0	0.9
	CAUC-C205	575/60/3	520-635	3.2	15	2/1.0	1.4	7.2	0.9
25	CAUC-C25G	200-230/60/3	180-220/208-254	13.3	20	3/1.0	4.1	20.7	0.9
	CAUC-C254	460/60/3	416-508	5.9	15	3/1.0	1.8	9.0	0.9
	CAUC-C255	575/60/3	520-635	4.6	15	3/1.0	1.4	7.2	0.9
30	CAUC-C30G	200-230/60/3	180-220/208-254	13.3	20	3/1.0	4.1	20.7	0.9
	CAUC-C304	460/60/3	416-508	5.9	15	3/1.0	1.8	9.0	0.9
	CAUC-C305	575/60/3	520-635	4.6	15	3/1.0	1.4	7.2	0.9
40	CAUC-C40G	200-230/60/3	180-220/208-254	17.4	20	4/1.0	4.1	20.7	0.9
	CAUC-C404	460/60/3	416-508	7.7	15	4/1.0	1.8	9.0	0.9
	CAUC-C405	575/60/3	520-635	6.0	15	4/1.0	1.4	7.2	0.9
50	CAUC-C50G	200-230/60/3	180-220/208-254	25.6	30	6/1.0	4.1	20.7	0.9
	CAUC-C504	460/60/3	416-508	11.3	15	6/1.0	1.8	9.0	0.9
	CAUC-C505	575/60/3	520-635	8.8	15	6/1.0	1.4	7.2	0.9
60	CAUC-C60G	200-230/60/3	180-220/208-254	25.6	30	6/1.0	4.1	20.7	0.9
	CAUC-C604	460/60/3	416-508	11.3	15	6/1.0	1.8	9.0	0.9
	CAUC-C605	575/60/3	520-635	8.8	15	6/1.0	1.4	7.2	0.9
80	CAUC-C80E	200/60/3	180-220	34	40	8/1.0	4.1	20.7	0.9
	CAUC-C80F	230/60/3	208-254	34	40	8/1.0	4.1	20.7	0.9
	CAUC-C804	460/60/3	416-508	15	20	8/1.0	1.8	9.0	0.9
	CAUC-C805	575/60/3	520-635	12	15	8/1.0	1.4	7.2	0.9
100	CAUC-D10E	200/60/3	180-220	50	60	12/1.0	4.1	20.7	0.9
	CAUC-D10F	230/60/3	208-254	50	60	12/1.0	4.1	20.7	0.9
	CAUC-D104	460/60/3	416-508	22	25	12/1.0	1.8	9.0	0.9
	CAUC-D105	575/60/3	520-635	17	20	12/1.0	1.4	7.2	0.9
120	CAUC-D12E	200/60/3	180-220	50	60	12/1.0	4.1	20.7	0.9
	CAUC-D12F	230/60/3	208-254	50	60	12/1.01	4.1	20.7	0.9
	CAUC-D124	460/60/3	416-508	22	25	12/1.0	1.8	9.0	0.9
	CAUC-D125	575/60/3	520-635	17	20	12/1.0	1.4	7.2	0.9

Notes:

1. Electric information is for each individual motor.
2. Maximum fuse size is permitted by NEC 440-22 is 300 percent of one motor RLA plus the RLA of the remaining motors.
3. Minimum circuit ampacity equals 125 percent of the RLA of one motor plus the RLA of the remaining motors.
4. All Kw values taken at conditions of 45 F saturated suction temperature at the compressor and 95 F ambient.
5. Local codes may take precedence.

# Dimensional Data (20Ton)

Figure DD-1 – CAUC-C20 Unit Dimensions, Recommended Clearances, Mounting Locations, Electric and Refrigerant Connection Sizes and Locations

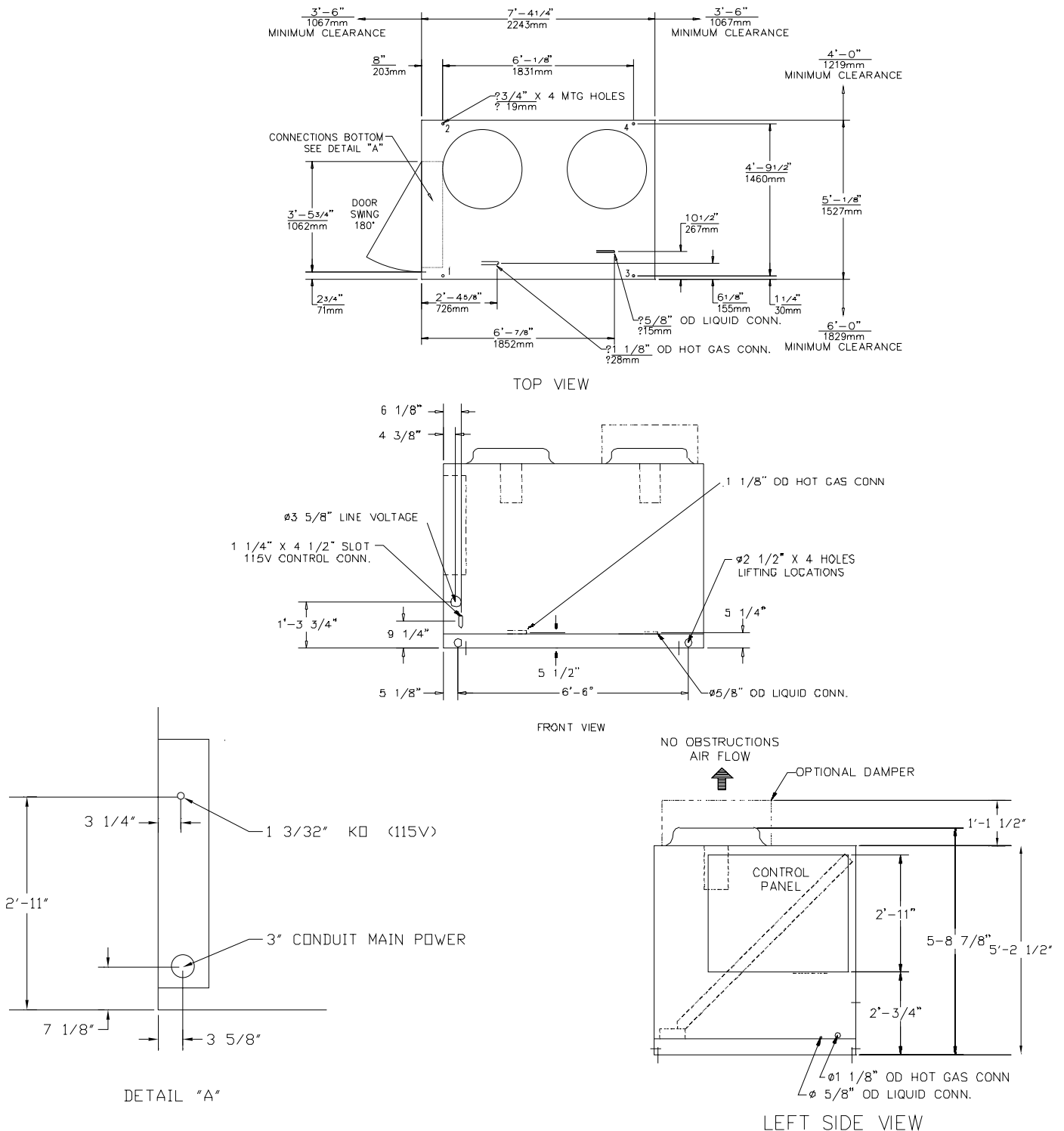



# Dimensional Data (25 Ton)

Figure DD-2 – CAUC-C25 Unit Dimensions, Recommended Clearances, Mounting Locations, Electric and Refrigerant Connection Sizes and Locations

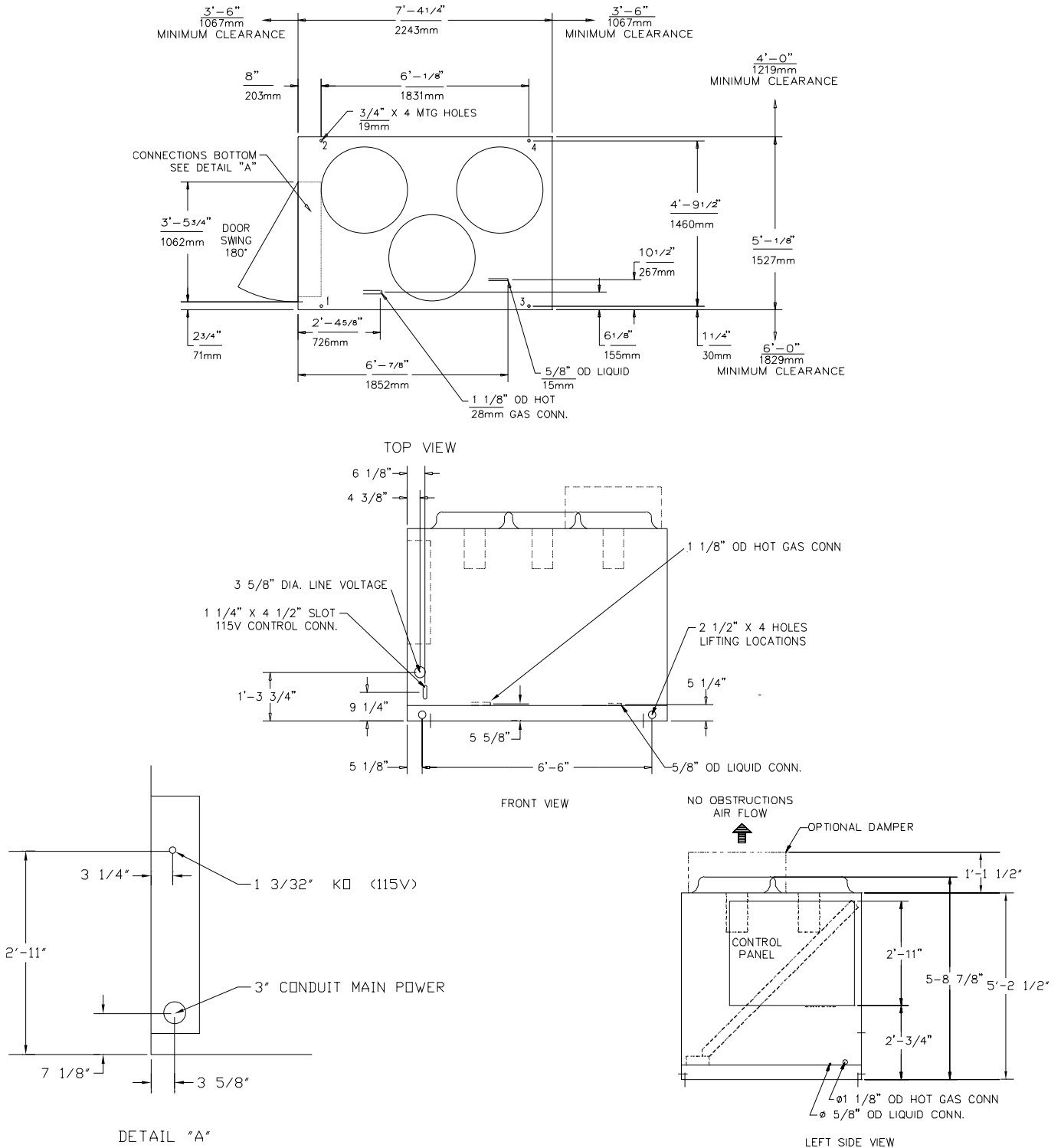

# Dimensional Data (30Ton)

Figure DD-3 – CAUC-C30 Unit Dimensions, Recommended Clearances, Mounting Locations, Electric and Refrigerant Connection Sizes and Locations

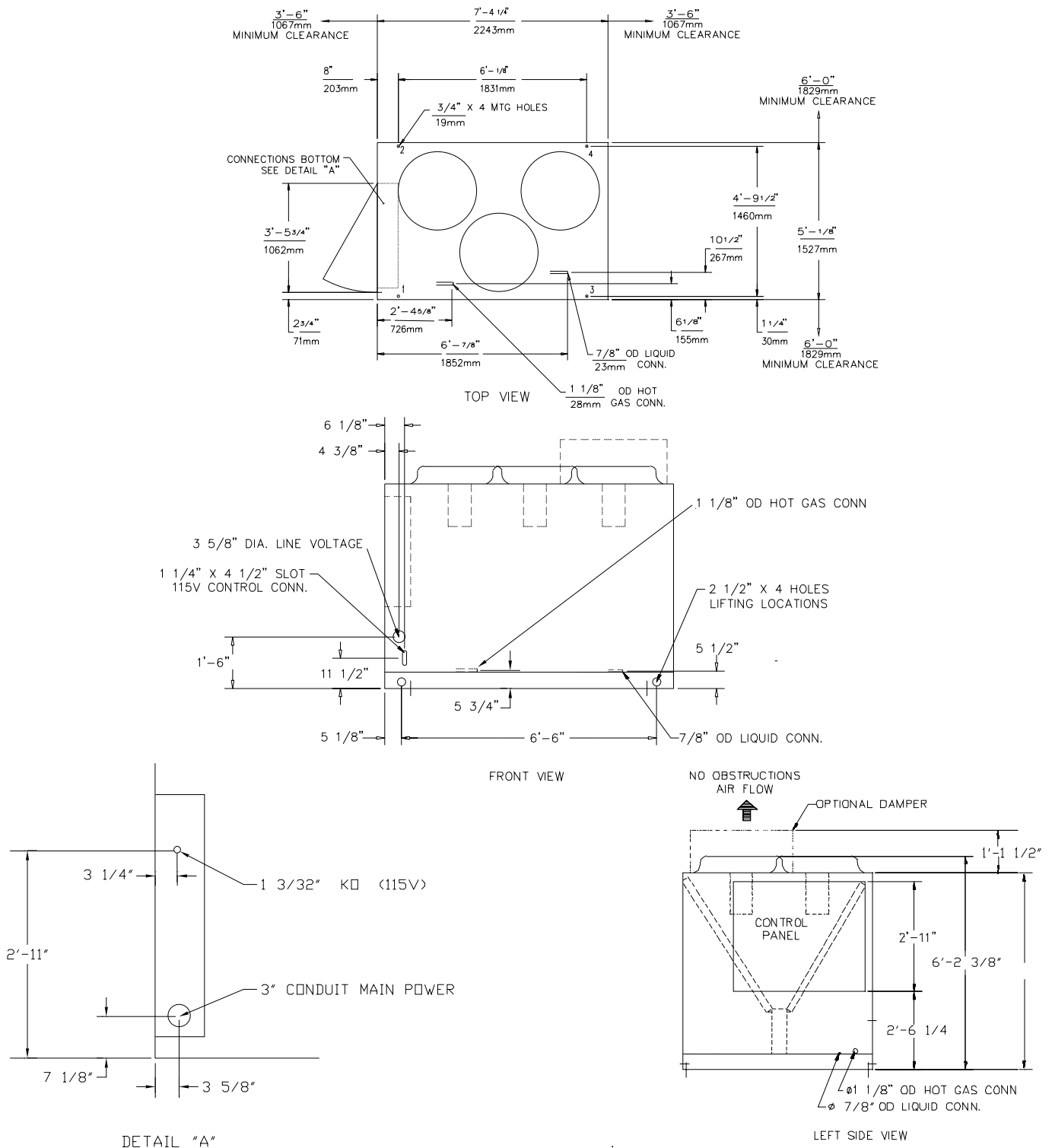



# Dimensional Data (40Ton)

Figure DD-4 - CAUC-C40 Unit Dimensions, Recommended Clearances, Mounting Locations, Electric and Refrigerant Connection Sizes and Locations

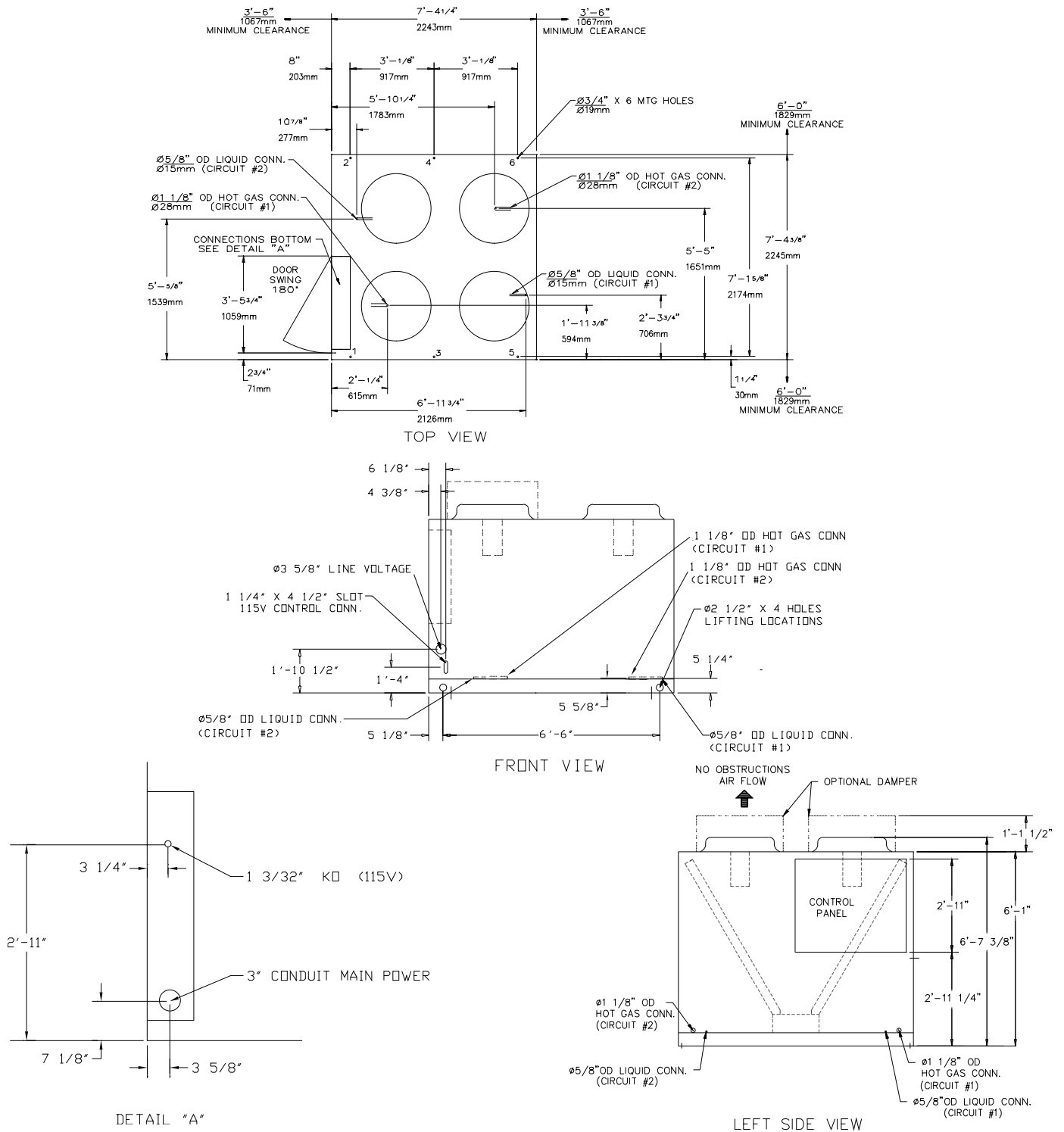

# Dimensional Data (50Ton)

Figure DD-5 – CAUC-C50 Unit Dimensions, Recommended Clearances, Mounting Locations, Electric and Refrigerant Connection Sizes and Locations

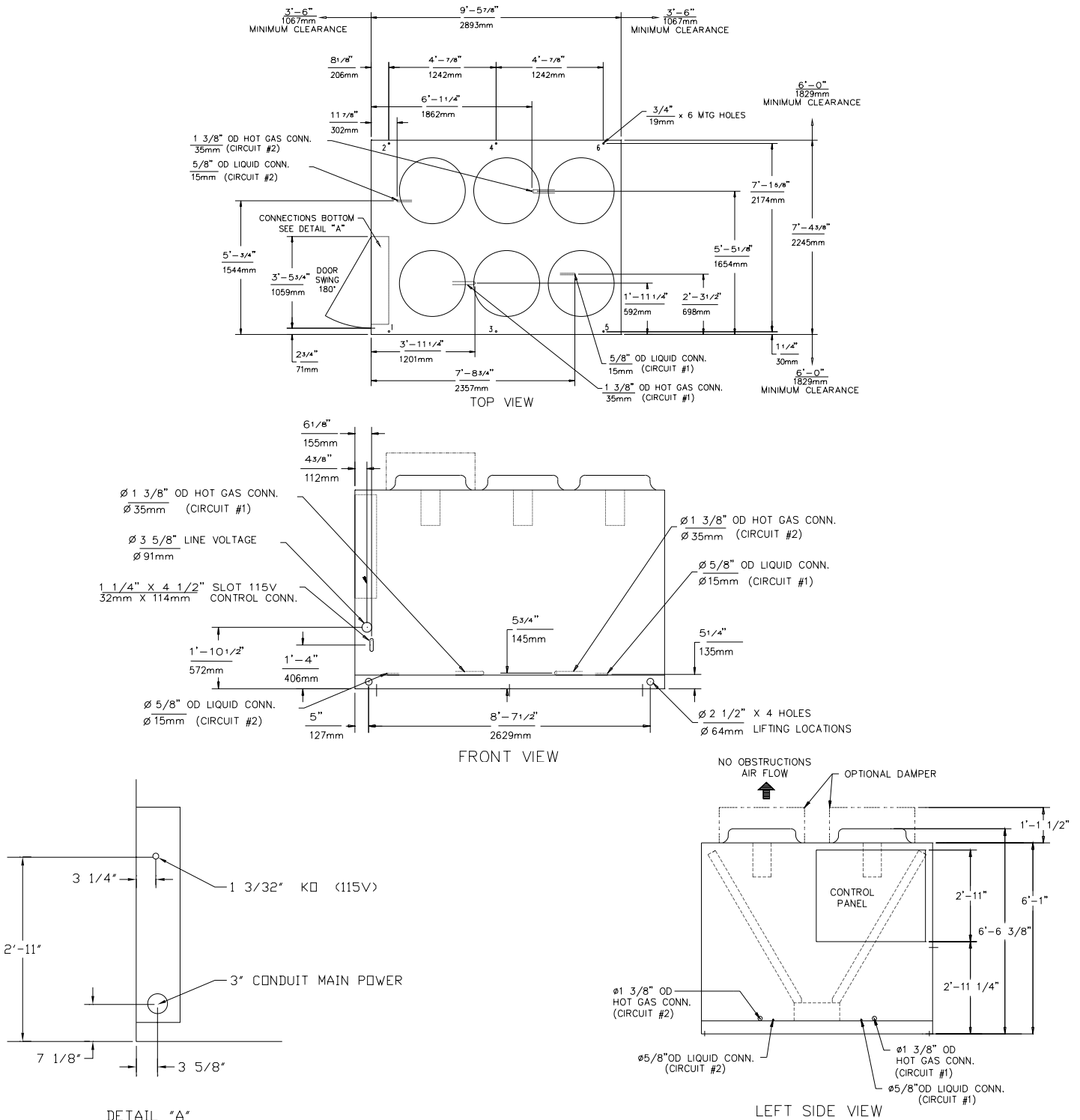



# Dimensional Data (60 Ton)

Figure DD-6 - CAUC-C60 Unit Dimensions, Recommended Clearances, Mounting Locations, Electric and Refrigerant Connection Sizes and Locations

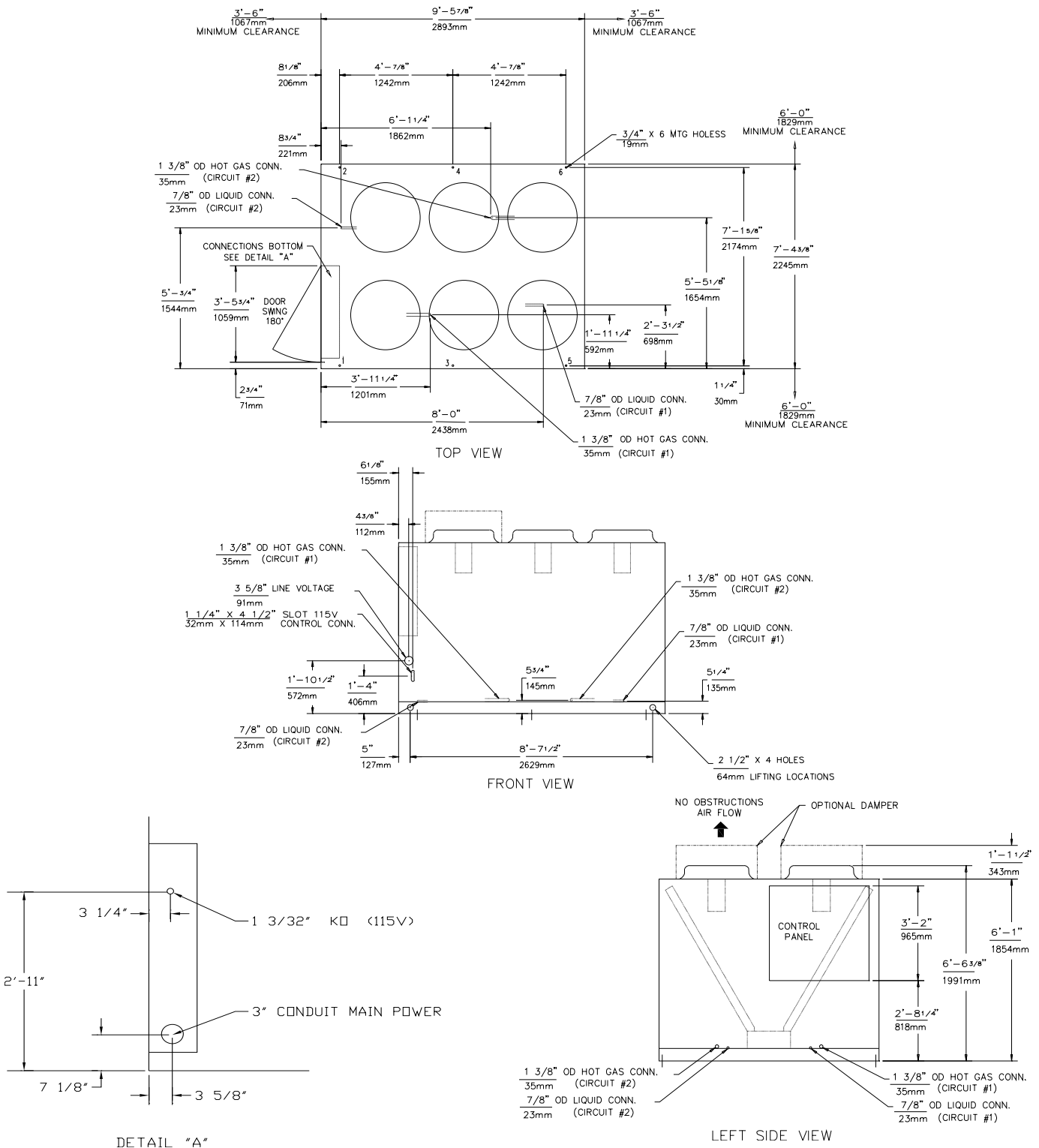

# Dimensional (80 Ton) Data

Figure DD-7 — CAUC-C80 Unit Dimensions, Recommended Clearances, Mounting Locations, Electric and Refrigerant Connection Sizes and Locations

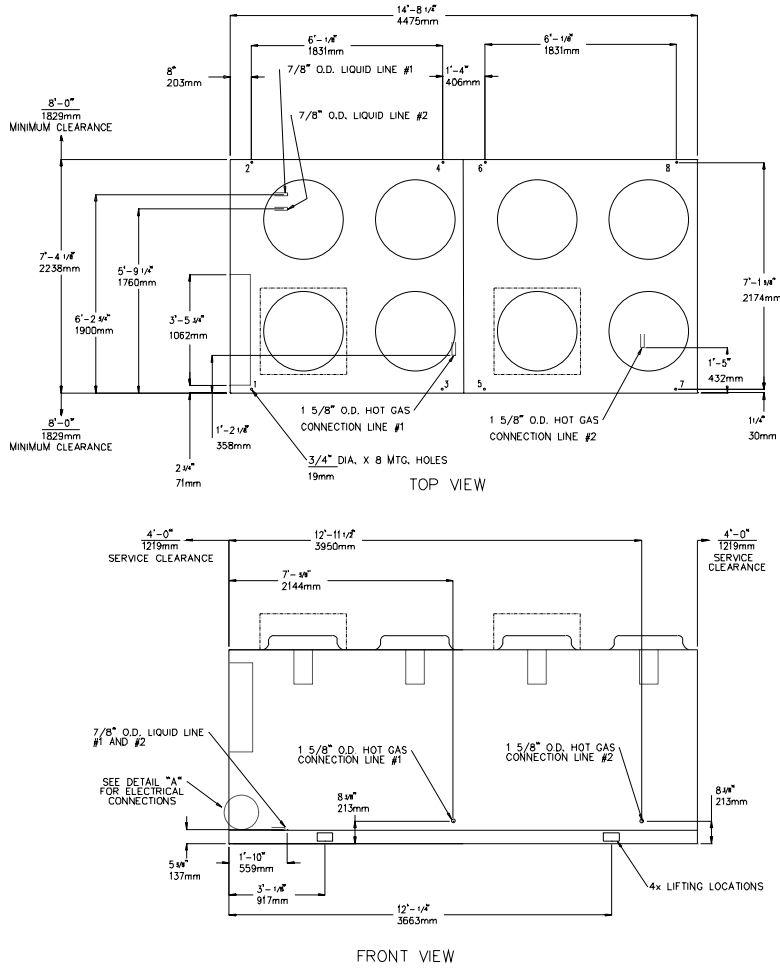

**NOTES:**

- HOT GAS DISCHARGE AND LIQUID LINE CONNECTION LOCATIONS SHOWN IN THE FRONT VIEW DO NOT REPRESENT HOLES IN THE UNIT PANEL. ACCESS TO THESE CONNECTIONS ARE PROVIDED BY THE CUSTOMERS.
- DIMENSIONAL TOLERANCE IS ± 1/8".

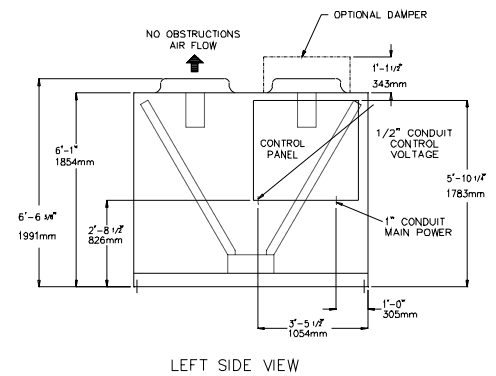
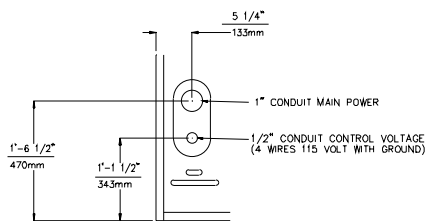

# Dimensional Data (100 Ton)

Figure DD-9 — CAUC-C100 Unit Dimensions, Recommended Clearances, Mounting Locations, Electric and Refrigerant Connection Sizes and Locations

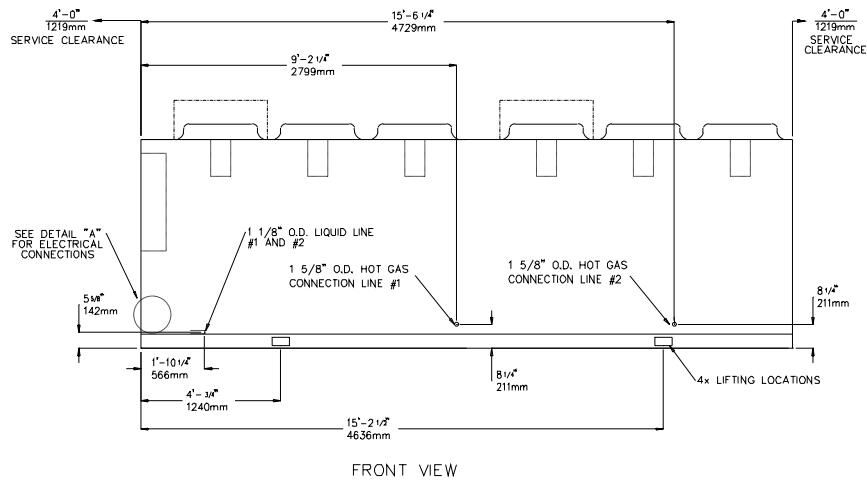
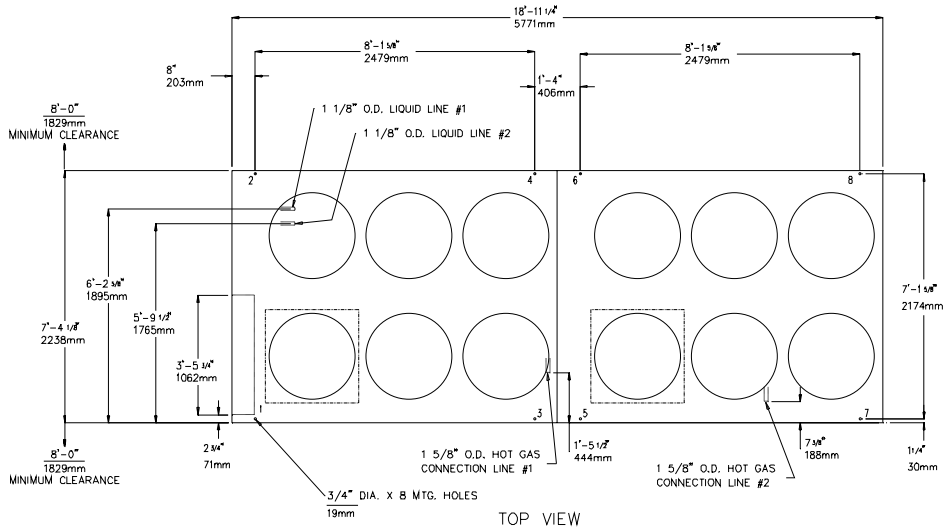

NOTES:

- HOT GAS DISCHARGE AND LIQUID LINE CONNECTION LOCATIONS SHOWN IN THE FRONT VIEW DO NOT REPRESENT HOLES IN THE UNIT PANEL. ACCESS TO THESE CONNECTIONS ARE PROVIDED BY THE CUSTOMERS.
- DIMENSIONAL TOLERANCE IS  $\pm 1/8"$ .

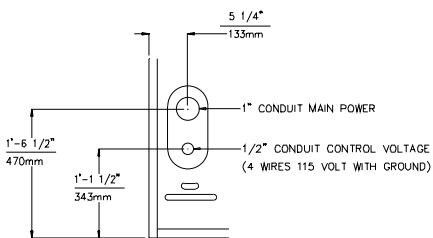

DETAIL "A"

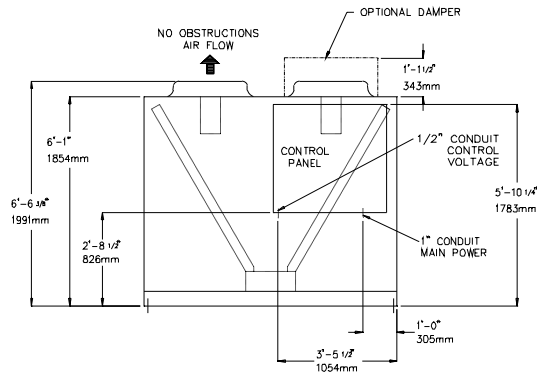

LEFT SIDE VIEW

# Dimensional Data (120 Ton)

Figure DD-10 — CAUC-C120 Unit Dimensions, Recommended Clearances, Mounting Locations, Electric and Refrigerant Connection Sizes and Locations

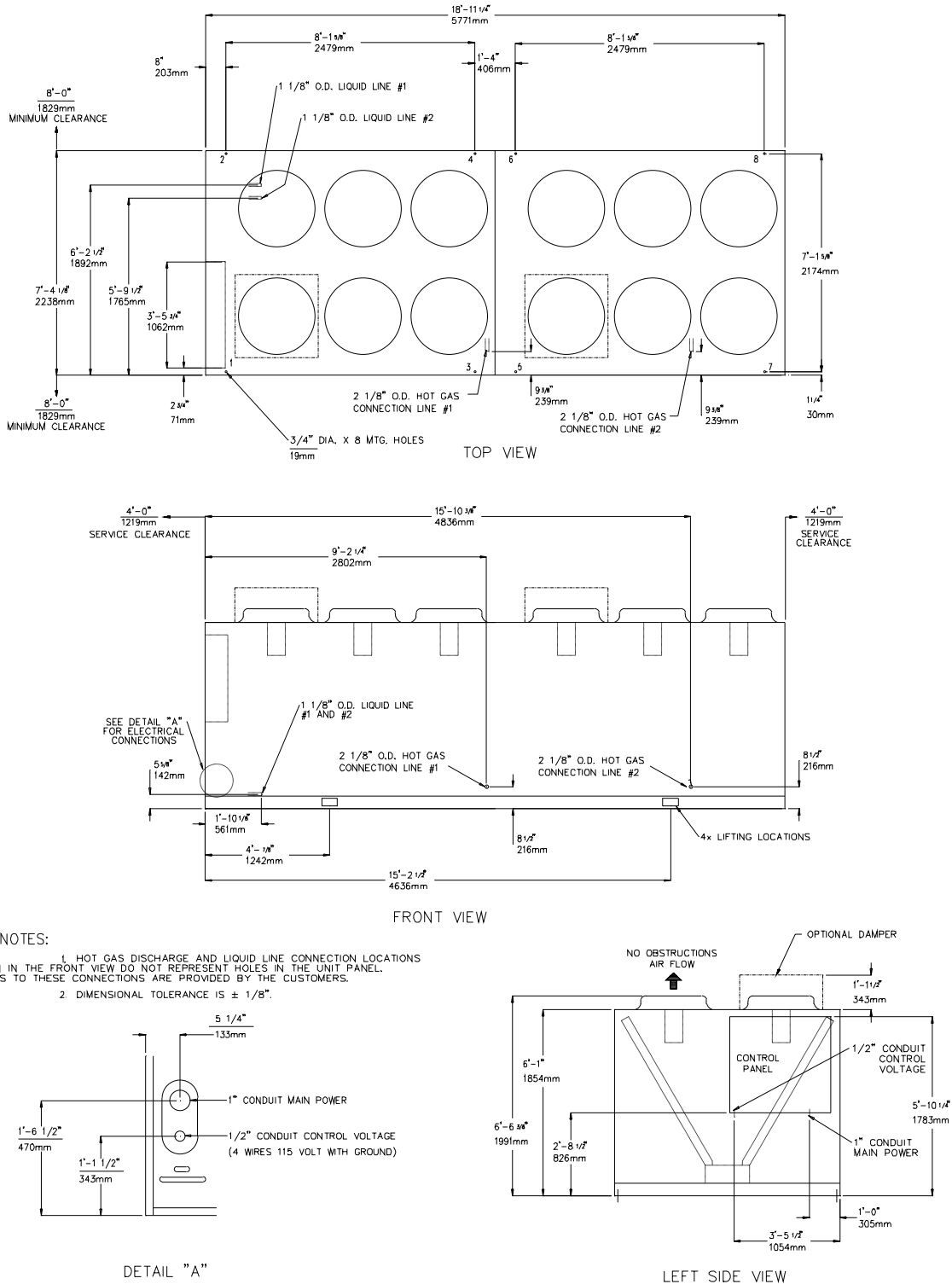

NOTES:

- HOT GAS DISCHARGE AND LIQUID LINE CONNECTION LOCATIONS SHOWN IN THE FRONT VIEW DO NOT REPRESENT HOLES IN THE UNIT PANEL. ACCESS TO THESE CONNECTIONS ARE PROVIDED BY THE CUSTOMERS.
- DIMENSIONAL TOLERANCE IS ± 1/8".

# Weights

**Figure W-1 – 20-30Tons**

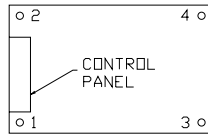

**Figure W-2 – 40-60Tons**

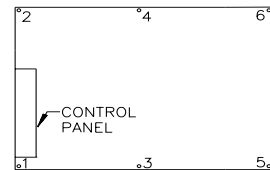

**Top View (Mounting Locations)**

**Table W-1 – 20 to 60 Ton Weights (Lbs./Kg.)**

Nominal Tons	Model Number	Operating Weight		Weight On Isolator At Mounting Locations												
		AL	CU	Loc. 1		Loc. 2		Loc. 3		Loc. 4		Loc. 5		Loc. 6		
20	CAUC-C20	Lb.	1146	1348	320	371	326	365	248	306	252	301	—	—	—	—
		Kg.	519.8	611.5	145.2	168.3	147.9	165.6	112.5	138.8	114.3	136.5				
25	CAUC-C25	Lb.	1190	1394	329	378	337	381	259	315	265	319	—	—	—	—
		Kg.	539.8	632.3	149.2	171.5	152.9	172.8	117.5	142.9	120.2	144.7				
30	CAUC-C30	Lb.	1302	1585	353	414	371	444	282	355	296	381	—	—	—	—
		Kg.	590.6	719.0	160.1	187.8	168.3	201.4	127.9	161.0	134.3	172.8				
40	CAUC-C40	Lb.	2048	2366	363	406	347	392	349	404	334	389	335	401	320	387
		Kg.	929.0	1073.2	164.7	184.2	157.4	177.8	158.3	183.3	151.5	176.5	152.0	181.9	145.2	175.5
50	CAUC-C50	Lb.	2280	2664	407	464	392	449	387	453	373	438	367	441	354	427
		Kg.	1034.2	1208.4	184.6	210.5	177.8	203.7	175.5	205.5	169.2	198.7	166.5	200.0	160.6	193.7
60	CAUC-C60	Lb.	2465	3010	433	515	420	505	417	511	405	501	401	507	389	497
		Kg.	1118.1	1365.3	196.4	233.6	190.5	229.1	189.2	231.8	183.7	227.3	181.9	230.0	176.5	225.4

**Figure W-3 – 80-120Tons**

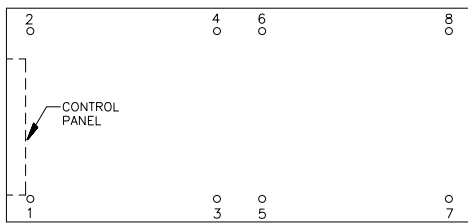

**Top View (Mounting Locations)**

**Table W-2 – 80 to 120 Ton Weights (Lbs./Kg.)**

Nominal Tons	Model Number	Coil Fin	Operating Weight		Weight On Isolator At Mounting Points							
			AL	CU	Loc. 1	Loc. 2	Loc. 3	Loc. 4	Loc. 5	Loc. 6	Loc. 7	Loc. 8
80	CAUC-C80	AL	Lb.	4036	514	478	522	485	524	487	532	494
		Kg.	1830.7	233.2	216.8	236.8	220.0	237.7	220.9	241.3	224.1	
100	CAUC-D10	CU	Lb.	4542	603	571	600	569	600	568	597	566
		Kg.	2060.3	273.5	259.0	272.2	258.1	272.2	257.6	270.8	256.7	
100	CAUC-D10	AL	Lb.	4911	631	600	630	598	629	598	628	597
		Kg.	2227.6	286.2	272.2	285.8	271.3	285.3	271.3	284.9	270.8	
120	CAUC-D12	CU	Lb.	5371	586	549	597	560	600	562	611	572
		Kg.	2436.3	265.8	249.0	270.8	254.0	272.2	254.9	277.1	259.5	
120	CAUC-D12	AL	Lb.	5472	698	666	700	668	700	668	702	670
		Kg.	2482.1	316.6	302.1	317.5	303.0	317.5	303.0	318.4	303.9	
120	CAUC-D12	CU	Lb.	5971	774	742	779	747	780	748	786	753
		Kg.	2708.4	351.1	336.6	353.4	338.8	353.8	339.3	356.5	341.6	

# Mechanical Specifications

---

## General

Factory-assembled and wired air cooled condensing unit. Units are constructed of 14-gauge welded galvanized steel frame with 14 and 16-gauge galvanized steel panels and access doors. Unit surface is phosphatized and finished with an air-dry paint. This air-dry paint finish is durable enough to withstand a 1000-consecutive-hour salt spray application in accordance with standard ASTM B117.

## Refrigeration Circuits and Control

The 20 to 30 ton units are single circuit. The 40 to 120 ton units are dual circuited. All the necessary controls to run the unit fans are provided. The control panel contains fan motor contactors, terminal point connection for compressor interlock and 115 volt control power transformer. Standard units will operate from 40 to 115 F. All units shipped with factory installed liquid line service valves.

## Condenser Coils and Fans

Condenser coils have configured aluminum fins mechanically bonded to copper tubing with integral subcooler. The coils are underwater burst/leak tested at 450 psi. Direct drive condenser fan motors have permanently lubricated ball bearings and thermal overload protection.

## Low Ambient Operation

Standard ambient control allows operation down to 40 F with cycling of condenser fans. Optional low ambient allows operation down to 0 F with external damper assembly for head pressure control. Refer to Options section for details.

## Options

### Low Ambient Control

Low ambient allows operation down to 0 F through the use of fan cycling and

head pressure control dampers. The control consists of a heavy gauge damper assembly, R-22 operator, tubing and grommet. All components are factory-mounted for both production and Packed Stock Plus units. Low ambient control must be ordered when the air-cooled condenser is matched with a CCKC heat recovery chiller.

## Copper Finned Condenser Coil

Copper fins are mechanically bonded to copper tubes for use in corrosive atmospheres. Nominal unit capacity remains the same.

## Spring Isolation Package

Spring isolators reduce transmission of noise and vibration to building structure, equipment, and adjacent spaces. Isolators consist of a cast, spring loaded, telescoping housing as the isolation medium. Mountings include built-in leveling bolts, resilient inserts that act as centering guides, and ribbed neoprene acoustical pads bonded to the bottom of the isolator. The kit includes instructions for field installation.

## Neoprene-in-shear Isolation Package

Neoprene isolators reduce transmission of noise and vibration to building structure, equipment, and adjacent spaces. Isolators have a steel plate and base completely imbedded in neoprene. Mountings have a 1/4-inch deflection. The kit includes instructions for field installation. Available on 20 to 60-ton units only.



**TRANE®**

**Trane**  
**A business of American**  
**Standard Companies**  
**[www.trane.com](http://www.trane.com)**

*For more information contact your  
local district office, or e-mail us at  
[comfort@trane.com](mailto:comfort@trane.com)*

Literature Order Number	ACDS-PRC001-EN
File Number	PLRF-ACDS-PRC0001-EN-04-2001
Supersedes	ACDS-DS-1 07/00
Stocking Location	Webb/Mason

*Trane has a policy of continuous product and product data improvement and reserves the right to change design and specifications without notice.*