



TRANE[®]

Vertical Upflow Horizontal Left Air Handlers

2/4TGB018-048A

1½ – 4 Ton

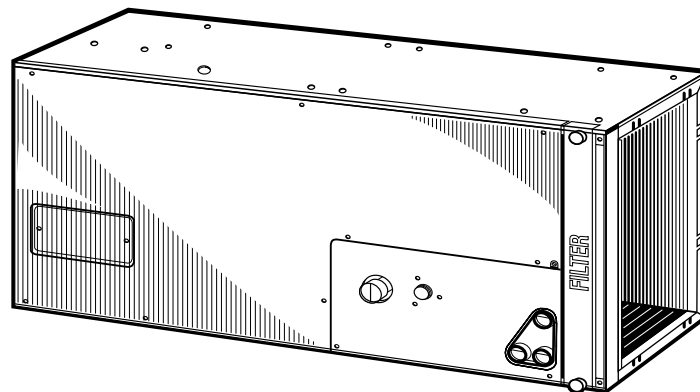
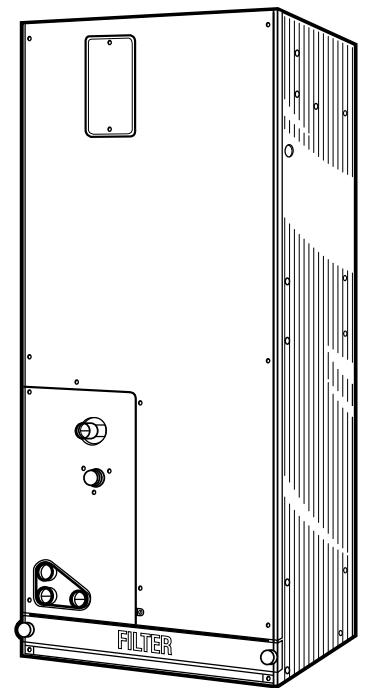

PUB. NO. 22-1778-06



Vertical Upflow Horizontal Left Air Handlers

Features:

- Full line 1 1/2 - 4 tons
- Expanded application fit with narrow cabinet profile
- Maximum depth 21" - fits pull-down staircase
- Exclusive maximum width 23.5" - fits 2-ft. wide door all sizes
- Convertible upflow to horizontal left (no tools required)
- Attractive enamel finish
- R 4.2 - 1" foil faced insulation
- Versatile duct flange - allows flush fit 3/4", 1" or 1.5" duct insulation
- Tight cabinet - low leakage by design
- IAQ (Indoor Air Quality) sloped/free draining pan (no standing water)
- Durable, glass-filled Lexan™ - Never rust, no leak drain pan
- Exclusive easy clean coil and drain pan
- Exclusive standard size replaceable fiberglass filters
- Easy to remove filters and blowers for easy cleaning and replacement
- Filter panel stamped with word "filter"
- Easy access electrical controls and hook-up
- Direct drive motor
- Polarized plugs for easy hook-up to electric heaters
- 200/230 volt primary and 24 volt secondary transformer
- Electric heaters with breaker option on all sizes
- Internally checked, mechanically connected TXV refrigerant control
- Factory installed non-bleed TXV
- **Optional extended warranties**



Contents

Features and Benefits	2	_
General Data	4	_
Performance Data	6	_
Wiring Diagrams	14	_
Field Wiring	16	_
Outline Drawings	19	_



General Data

MODEL	2/4TGB3F18A1000A		2/4TGB3F25A1000A		2/4TGB3F30A1000A		2/4TGB3F36A1000A	
RATED VOLTS/PH/Hz.	208-230/1/60		208-230/1/60		208-230/1/60		208-230/1/60	
RATINGS ①	See O.D. Specs		See O.D. Specs		See O.D. Specs		See O.D. Specs	
INDOOR COIL — Type	Plate Fin		Plate Fin		Plate Fin		Plate Fin	
Rows — F.P.I.	3 - 14		3 - 14		4 - 14		4 - 14	
Face Area (sq. ft.)	2.29		2.29		2.75		2.75	
Tube Size (in.)	3/8 - Copper		3/8 - Copper		3/8 - Copper		3/8 - Copper	
Refrigerant Control	TXV-NB④		TXV-NB④		TXV-NB④		TXV-NB④	
Drain Conn. Size (in.) ②	3/4 NPT		3/4 NPT		3/4 NPT		3/4 NPT	
INDOOR FAN — Type	Centrifugal		Centrifugal		Centrifugal		Centrifugal	
Diameter-Width (In.)	10 X 7		10 X 7		10 X 8		10 X 8	
No. Used	1		1		1		1	
Drive - No. Speeds	Direct - 3		Direct - 3		Direct - 3		Direct - 3	
CFM vs. in. w.g. ①	See FanTable		See FanTable		See FanTable		See FanTable	
No. Motors — H.P.	1 - 1/6		1 - 1/6		1 - 1/4		1 - 1/3	
Motor Speed R.P.M.	1060		1060		850		1075	
Volts/Ph/Hz	208-230/1/60		208-230/1/60		208-230/1/60		208-230/1/60	
F.L. Amps - L.R. Amps	1.15 - 1.72		1.15 - 1.72		2.0 - 2.86		2.1 - 5.26	
FILTER								
Vertical Applications								
Filter Furnished?	YES		YES		YES		YES	
Lo. Vel. (No.-Size-Thk)	1 - 16 X 20		1 - 16 X 20		1 - 16 X 20		1 - 16 X 20	
Horizontal Applications								
Filter Furnished?	NO		NO		NO		NO	
Recommended Size ③	See NOTE ③		See NOTE ③		See NOTE ③		See NOTE ③	
REFRIGERANT								
	R-22	R-410A	R-22	R-410A	R-22	R-410A	R-22	R-410A
Ref. Line Connections	Brazed	Brazed	Brazed	Brazed	Brazed	Brazed	Brazed	Brazed
Conn. Size -- in. Gas	5/8	1/2	3/4	5/8	3/4	3/4	7/8	3/4
Conn. Size -- in. Liq.	1/4	3/8	5/16	3/8	5/16	3/8	3/8	3/8
DIMENSIONS								
	H x W x D		H x W x D		H x W x D		H x W x D	
Crated (In.)	47.5 X 21 X 24.5		47.5 X 21 X 24.5		53.7 X 21 X 24.7		53.7 X 21 X 24.7	
Uncrated	45.7 X 18 X 21		45.7 X 18 X 21		52 X 18 X 21		52 X 18 X 21	
WEIGHT								
Shipping (Lbs.)/Net (Lbs)	124 / 109		125 / 110		135 / 119		135 / 119	

① These Air Handlers are A.R.I. certified with various Split System Air Conditioners and Heat Pumps (ARI STANDARD 210/240).

Refer to the Split System Outdoor Unit Product Data Guides for performance data.

② 3/4" Male Plastic Pipe (Ref.: ASTM 1785-76)

③ Minimum filter size for horizontal applica-

tions will be based on airflow selection and will be calculated as follows:

Low Velocity Filter: Face area (Sq. Ft.) = CFM / 300

High Velocity Filter: Face area (Sq. Ft.) = CFM / 500

④ Torque spec for TXV = Tighten 1/6 turn past finger tight

⑤ For customer ease of filter maintenance, it is recommended that a properly sized **remote filter** and grille be installed for horizontal applications. Airflow should not exceed the face velocity of the filter being used. **The factory installed filter should then be removed from the unit.**



General Data

PRODUCT SPECIFICATIONS

MODEL	2/4TGB3F42A1000A	2/4TGB3F48A1000A
RATED VOLTS/PH/HZ.	208-230/1/60	208-230/1/60
RATINGS ①	See O.D. Specs	See O.D. Specs
INDOOR COIL — Type	Plate Fin	Plate Fin
Rows — F.P.I.	3 - 14	3 - 14
Face Area (sq. ft.)	4.58	6.19
Tube Size (in.)	3/8 - Copper	3/8 - Copper
Refrigerant Control	TXV-NB ④	TXV-NB ④
Drain Conn. Size (in.) ②	3/4 NPT	3/4 NPT
DUCT CONNECTIONS	See Outline Drawing	See Outline Drawing
INDOOR FAN — Type	Centrifugal	Centrifugal
Diameter-Width (In.)	10 X 10	10 X 10
No. Used	1	1
Drive - No. Speeds	Direct - 3	Direct - 3
CFM vs. in. w.g.	See Fan Table	See Fan Table
No. Motors — H.P.	1 - 1/2	1 - 1/2
Motor Speed R.P.M.	1075	1075
Volts/Ph/Hz	208-230/1/60	208-230/1/60
F.L. Amps	3.9 - 8.7	3.5 - 8.3
FILTER		
Vertical Applications		
Filter Furnished?	Yes	Yes
Lo. Vel. (No.-Size-Thk)	1 - 20 X 20	1 - 22X 20
Horizontal Applications		
Filter Furnished?	See Note ⑤	See Note ⑤
Recommended Size	See Note ③	See Note ③
REFRIGERANT		
	R-22	R-410A
Ref. Line Connections	Brazed	Brazed
Conn. Size — in. Gas	7/8	3/4
Conn. Size — in. Liq.	3/8	3/8
DIMENSIONS		
	H x W x D	H x W x D
Crated (In.)	50.25 X 26 X 24.5	59.25 X 26 X 24.5
Uncrated	48.25 X 23.5 X 21.5	57.25 X 23.5 X 21.5
WEIGHT		
Shipping (Lbs.)/Net (Lbs.)	147 / 131	172 / 153

① These Air Handlers are A.R.I. certified with various Split System Air Conditioners and Heat Pumps (ARI STANDARD 210/240). Refer to the Split System Outdoor Unit Product Data Guides for performance data.

② 3/4" Male Plastic Pipe (Ref.: ASTM 1785-76)

③ Minimum filter size for horizontal applications will be based on airflow selection and will be calculated as follows:

Low Velocity Filter: Face area (Sq. Ft.) = CFM / 300

High Velocity Filter: Face area (Sq. Ft.) = CFM / 500

④ Torque Spec for TXV = Tighten 1/6 turn past finger tight

⑤ For customer ease of filter maintenance, it is recommended that a properly sized **remote filter** and grille be installed for horizontal applications. Airflow should not exceed the face velocity of the filter being used. **The factory installed filter should then be removed from the unit.**



Performance Data

Airflow Performance 2/4TGB3F18A1000A: Wet coil, No Heaters												
EXTERNAL STATIC PRESSURE (in.w.g.)	AIRFLOW (CFM)											
	VERTICAL						HORIZONTAL					
	230 VOLTS			208 VOLTS			230 VOLTS			208 VOLTS		
	HIGH	MED	LOW	HIGH	MED	LOW	HIGH	MED	LOW	HIGH	MED	LOW
0	895	830	648	805	735	567	878	814	659	791	727	576
0.1	864	799	625	771	711	545	841	781	626	758	695	548
0.2	828	766	598	738	679	514	802	743	591	722	659	514
0.3	790	731	567	703	644	477	760	702	555	683	621	476
0.4	748	691	531	664	604	437	715	656	517	639	580	437
0.5	702	645	487	619	559	395	665	607	473	591	536	393
0.6	649	590	433	565	506	345	608	552	422	536	486	341
0.7	582	525	364	499	443	283	544	490	358	474	428	276
0.8	497	445	276	419	364	198	468	418	277	401	357	191
0.9	385	347	164	322	263	78	378	335	172	316	267	75
NOTES:	With filter, no horizontal drip tray Small apex baffle						As shipped, with filter					

Airflow Performance 2/4TGB3F25A1000A: Wet coil, No Heaters												
EXTERNAL STATIC PRESSURE (in.w.g.)	AIRFLOW (CFM)											
	VERTICAL						HORIZONTAL					
	230 VOLTS			208 VOLTS			230 VOLTS			208 VOLTS		
	HIGH	MED	LOW	HIGH	MED	LOW	HIGH	MED	LOW	HIGH	MED	LOW
0	1035	965	773	926	854	692	1015	955	786	935	878	702
0.1	992	934	730	885	814	648	962	910	759	891	834	675
0.2	944	884	695	845	777	616	916	864	718	849	792	632
0.3	896	834	661	804	741	582	872	819	674	807	750	586
0.4	849	788	621	761	700	537	824	773	628	761	705	544
0.5	800	744	569	713	651	477	768	725	580	710	655	501
0.6	742	690	501	655	591	403	702	670	521	650	596	444
0.7	665	603	410	582	516	319	625	601	438	579	526	351
0.8	555	453	293	489	424	238	538	510	314	493	441	190
0.9	396	197	146	367	313	174	443	387	122	391	338	-
NOTES:	With filter, no horizontal drip tray Small apex baffle						As shipped, with filter					



Performance Data

Airflow Performance 2/4TGB3F30A1000A: Wet coil, No Heaters												
EXTERNAL STATIC PRESSURE (in.w.g.)	AIRFLOW (CFM)											
	VERTICAL						HORIZONTAL					
	230 VOLTS			208 VOLTS			230 VOLTS			208 VOLTS		
	HIGH	MED	LOW	HIGH	MED	LOW	HIGH	MED	LOW	HIGH	MED	LOW
0	1114	988	841	976	835	699	1118	1014	858	992	856	721
0.1	1083	960	817	941	818	682	1080	979	836	969	839	702
0.2	1046	935	799	914	801	665	1036	947	815	939	820	686
0.3	1004	908	781	887	781	647	990	913	792	905	798	669
0.4	958	875	757	856	756	625	942	874	764	867	770	648
0.5	908	834	723	818	725	597	893	827	729	824	734	619
0.6	851	782	679	770	684	562	838	770	685	772	688	581
0.7	783	719	624	708	632	519	772	705	630	709	631	532
0.8	699	645	560	633	565	466	685	630	563	629	562	471
0.9	594	560	491	545	483	404	565	548	485	526	479	398
NOTES:	With filter, no horizontal drip tray Small apex baffle						As shipped, with filter					

Airflow Performance 2/4TGB3F36A1000A: Wet coil, No Heaters												
EXTERNAL STATIC PRESSURE (in.w.g.)	AIRFLOW (CFM)											
	VERTICAL						HORIZONTAL					
	230 VOLTS			208 VOLTS			230 VOLTS			208 VOLTS		
	HIGH	MED	LOW	HIGH	MED	LOW	HIGH	MED	LOW	HIGH	MED	LOW
0	1305	1191	1102	1239	1062	957	1262	1187	1112	1211	1080	967
0.1	1259	1154	1076	1200	1039	947	1211	1146	1080	1164	1051	948
0.2	1209	1112	1041	1154	1012	924	1156	1082	1031	1114	1007	930
0.3	1156	1066	1001	1105	980	895	1099	1012	975	1062	955	902
0.4	1101	1018	958	1054	941	863	1044	946	917	1009	901	858
0.5	1043	968	910	1000	896	826	986	888	860	952	845	797
0.6	981	911	857	939	841	781	922	832	800	889	785	722
0.7	911	843	793	866	776	721	843	768	731	813	715	641
0.8	832	757	713	773	697	636	738	676	641	717	627	568
0.9	739	641	610	649	603	511	593	531	517	592	510	520
NOTES:	With filter, no horizontal drip tray Small apex baffle						As shipped, with filter					



Performance Data

Airflow Performance 2/4TGB3F42A1000A: Wet coil, No Heaters												
EXTERNAL STATIC PRESSURE (in.w.g.)	AIRFLOW (CFM)											
	VERTICAL						HORIZONTAL					
	230 VOLTS			208 VOLTS			230 VOLTS			208 VOLTS		
	HIGH	M-HI	LOW	HIGH	M-HI	LOW	HIGH	M-HI	LOW	HIGH	M-HI	LOW
0	1925	1823	1432	1833	1691	1212	1870	1788	1424	1786	1674	1662
0.1	1850	1753	1399	1758	1636	1192	1791	1724	1397	1728	1612	1621
0.2	1765	1676	1363	1686	1563	1168	1717	1648	1358	1657	1545	1558
0.3	1673	1597	1317	1611	1489	1136	1641	1569	1309	1580	1476	1491
0.4	1579	1518	1255	1530	1421	1091	1559	1490	1251	1500	1404	1422
0.5	1484	1440	1175	1439	1358	1031	1466	1411	1184	1416	1328	1350
0.6	1388	1358	1078	1340	1286	956	1363	1326	1105	1326	1244	1262
0.7	1292	1266	966	1233	1182	868	1249	1225	1014	1223	1146	1135
0.8	1192	1154	846	1123	1013	769	1127	1090	906	1096	1027	940
0.9	1084	1008	726	1015	734	663	1003	900	778	933	878	636
NOTES:	With filter, no horizontal drip tray Small apex baffle						As shipped, with filter					

Airflow Performance 2/4TGB3F48A1000A: Wet coil, No Heaters												
EXTERNAL STATIC PRESSURE (in.w.g.)	AIRFLOW (CFM)											
	VERTICAL						HORIZONTAL					
	230 VOLTS			208 VOLTS			230 VOLTS			208 VOLTS		
	HIGH	M-HI	LOW	HIGH	M-HI	LOW	HIGH	M-HI	LOW	HIGH	M-LO	LOW
0	1917	1664	1309	1836	1473	1101	1787	1645	1391	1751	1510	1134
0.1	1830	1615	1308	1767	1447	1108	1715	1579	1366	1678	1465	1157
0.2	1751	1561	1287	1698	1413	1102	1637	1519	1329	1606	1418	1138
0.3	1675	1501	1256	1627	1372	1086	1555	1454	1282	1532	1362	1102
0.4	1596	1437	1218	1551	1322	1059	1472	1376	1223	1451	1295	1062
0.5	1511	1366	1173	1470	1263	1022	1387	1284	1153	1363	1215	1024
0.6	1420	1289	1118	1382	1192	972	1298	1181	1072	1266	1125	983
0.7	1323	1202	1045	1288	1106	905	1201	1075	981	1163	1027	926
0.8	1223	1104	942	1188	1000	817	1091	980	881	1055	929	830
0.9	1126	992	794	1086	869	702	962	911	775	947	840	663
NOTES:	With filter, no horizontal drip tray Small apex baffle						As shipped, with filter					



Performance Data

MODULAR AIR HANDLER		HEATER MODEL NUMBER BAYHTR				
MODEL NUMBER	APPLICATION	1405 4.80kw	1408 7.68kw	1410 3410 9.60kw	1415 3415 15.36kw	1419 19.20kw
NUMBER OF HEATER RACKS		1	2	2	3	4
2/4TGB3F18A	A/C or Elec. Furnace	L	L	L	N/A	N/A
	Heat Pump	L	M	H	N/A	N/A
2/4TGB3F25A	A/C or Elec. Furnace	L	L	L	L	N/A
	Heat Pump	L	M	M	H	N/A
2/4TGB3F30A	A/C or Elec. Furnace	L	L	L	L	N/A
	Heat Pump	L	L	L	M	N/A
2/4TGB3F36A	A/C or Elec. Furnace	L	L	L	L	N/A
	Heat Pump	L	L	L	H	N/A
2/4TGB3F42A	A/C or Elec. Furnace	L	L	L	L	N/A
	Heat Pump	L	L	L	H	N/A
2/4TGB3F48A	A/C or Elec. Furnace	L	L	L	L	L
	Heat Pump	L	L	L	H	H

(L)Low, (M)Medium, (H)High Indicate minimum heating speed setting for blower/motor operation. N/A - not applicable

MODEL	"A" INCHES
2/4TGB3F18A1	1-3/8
2/4TGB3F25A1	1-3/8
2/4TGB3F30A1	1-1/2
2/4TGB3F36A1	1-1/8
2/4TGB3F42A1	2-1/8
2/4TGB3F48A1	1-1/2
FOR FACTORY OEM MOTORS	



Performance Data

PRESSURE DROP FOR ELECTRIC HEATERS IN AIR HANDLER MODELS

AIRFLOW CFM	NUMBER OF RACKS			
	1	2	3	4
600	0.01	0.02	0.02	
700	0.01	0.02	0.02	
800	0.02	0.03	0.03	0.04
900	0.03	0.03	0.04	0.05
1000	0.04	0.04	0.05	0.06
1100	0.04	0.05	0.06	0.07
1200	0.05	0.06	0.07	0.08
1300	0.06	0.07	0.08	0.09
1400	0.07	0.08	0.10	0.11
1500	0.08	0.09	0.11	0.13
1600	0.09	0.10	0.12	0.15
1700	0.10	0.11	0.14	0.17
1800	0.11	0.13	0.16	0.19
1900	0.13	0.15	0.18	0.21
2000	0.14	0.17	0.23	0.23

HEATER RACKS	
HEATER MODEL NO.	NO. OF RACKS
BAYHTR1405	1
BAYHTR1408	2
BAYHTR1/3410	2
BAYHTR1/3415	3
BAYHTR1419	4



Performance Data

2/4TGB3F18A WIRING DATA Indoor Blower Motor Powered from Heater Circuit 1											
Heater Model No.	Number of Circuits/Phase	240 VOLT					208 VOLT				
		Capacity		Heater Amps per Circuit	Minimum Circuit Ampacity	Maximum Overload Protection	Capacity		Heater Amps per Circuit	Minimum Circuit Ampacity	Maximum Overload Protection
		KW	BTUH				KW	BTUH			
No Heater	-	-	-	-	1	15	-	-	-	1	15
BAYHTR1405+++	1/1	4.80	16400	20	26	30	3.60	12300	17.3	23	25
BAYHTR1408+++	1/1	7.68	26200	32	41	45	5.77	19700	27.7	36	40
BAYHTR1410+++	1/1	9.60	32500	40	51	60	7.21	24600	34.6	45	45
BAYHTR3410000	1/3	9.60	32800	34.6	43	45	7.21	24600	30	37	40

* Circuit 1/Circuit 2 (Minimum Circuit Ampacity for Circuit 1 includes Blower Motor Amp
+++ = 000, PDC, BRK 000 = pigtails, PDC= contains pull disconnect, BRK=contains Circuit disconnects
IMPORTANT: Any power supply and/or combination power supply, circuit or circuits must be wired and protected in accordance with local Electrical Codes.

2/4TGB3F25A WIRING DATA Indoor Blower Motor Powered from Heater Circuit 1											
Heater Model No.	Number of Circuits/Phase	240 VOLT					208 VOLT				
		Capacity		Heater Amps per Circuit	Minimum Circuit Ampacity	Maximum Overload Protection	Capacity		Heater Amps per Circuit	Minimum Circuit Ampacity	Maximum Overload Protection
		KW	BTUH				KW	BTUH			
No Heater	-	-	-	-	1	15	-	-	-	1	15
BAYHTR1405+++	1/1	4.80	16400	20	26	30	3.60	12300	17.3	23	25
BAYHTR1408+++	1/1	7.68	26200	32	41	45	5.77	19700	27.7	36	40
BAYHTR1410+++	1/1	9.60	32800	40	51	60	7.21	24600	34.6	45	45
BAYHTR3410 000	1/3	9.60	32800	34.6	43	45	7.21	24600	30	37	40
BAYHTR1415 BRK	2/1	15.36	52400	40/24	51*/30	60*/30	11.52	39300	34.6/20.8	45*/26	45*/30
BAYHTR3415 000	1/3	15.36	52400	38.2	49	50	11.52	39300	34	43	45

* Circuit 1/Circuit 2 (Minimum Circuit Ampacity for Circuit 1 includes Blower Motor Amp
+++ = 000, PDC, BRK 000 = pigtails, PDC= contains pull disconnect, BRK=contains Circuit disconnects
IMPORTANT: Any power supply and/or combination power supply, circuit or circuits must be wired and protected in accordance with local Electrical Codes.



Performance Data

2/4TGB3F30A WIRING DATA
Indoor Blower Motor Powered from Heater Circuit 1

Heater Model No.	Number of Circuits/Phase	240 VOLT					208 VOLT				
		Capacity		Heater Amps per Circuit	Minimum Circuit Ampacity	Maximum Overload Protection	Capacity		Heater Amps per Circuit	Minimum Circuit Ampacity	Maximum Overload Protection
		KW	BTUH				KW	BTUH			
No Heater	-	-	-	-	3	15	-	-	-	3	15
BAYHTR1405+++	1/1	4.80	16400	20	28	30	3.60	12300	17.3	24	25
BAYHTR1408+++	1/1	7.68	26200	32	43	45	5.77	19700	27.7	37	40
BAYHTR1410+++	1/1	9.60	32800	40	53	60	7.20	24600	34.6	46	50
BAYHTR3410 000	1/3	9.60	32800	34.6	43	45	7.20	24600	30	37	40
BAYHTR1415 BRK	2/1	15.36	52400	40/24	53*/30	60*/30	11.53	39300	34.6/20.8	46*/26	50*/30
BAYHTR3415 000	1/3	15.36	52400	38.2	50	50	11.53	39300	33.1	43	45

* Circuit 1/Circuit 2 (Minimum Circuit Ampacity for Circuit 1 includes Blower Motor Amp
+++ = 000, PDC, BRK 000 = pigtails, PDC= contains pull disconnect, BRK=contains Circuit disconnects
IMPORTANT: Any power supply and/or combination power supply, circuit or circuits must be wired and protected in accordance with local Electrical Codes.

2/4TGB3F36A WIRING DATA
Indoor Blower Motor Powered from Heater Circuit 1

Heater Model No.	Number of Circuits/Phase	240 VOLT					208 VOLT				
		Capacity		Heater Amps per Circuit	Minimum Circuit Ampacity	Maximum Overload Protection	Capacity		Heater Amps per Circuit	Minimum Circuit Ampacity	Maximum Overload Protection
		KW	BTUH				KW	BTUH			
No Heater	-	-	-	-	3	15	-	-	-	3	15
BAYHTR1405+++	1/1	4.80	16400	20	28	30	3.60	12300	17.3	24	25
BAYHTR1408+++	1/1	7.68	26200	32	43	45	5.77	19700	27.7	37	40
BAYHTR1410+++	1/1	9.60	32800	40	53	60	7.20	24600	34.6	46	50
BAYHTR3410 000	1/3	9.60	32800	34.6	43	45	7.20	24600	30	37	40
BAYHTR1415 BRK	2/1	15.36	52400	40/24	53*/30	60*/30	11.53	39300	34.6/20.8	46*/26	50*/30
BAYHTR3415 000	1/3	15.36	52400	38.2	50	50	11.53	39300	33.1	44	45

* Circuit 1/Circuit 2 (Minimum Circuit Ampacity for Circuit 1 includes Blower Motor Amp
+++ = 000, PDC, BRK 000 = pigtails, PDC= contains pull disconnect, BRK=contains Circuit disconnects
IMPORTANT: Any power supply and/or combination power supply, circuit or circuits must be wired and protected in accordance with local Electrical Codes.



Performance Data

2/4TGB3F42A1000A WIRING DATA Indoor Blower Motor Powered from Heater Circuit 1											
Heater Model No.	Number of Circuits/Phase	240 VOLT					208 VOLT				
		Capacity		Heater Amps per Circuit	Minimum Circuit Ampacity	Maximum Overload Protection	Capacity		Heater Amps per Circuit	Minimum Circuit Ampacity	Maximum Overload Protection
		KW	BTUH				KW	BTUH			
No Heater	-	-	-	-	5	15	-	-	-	5	15
BAYHTR1405+++	1/1	4.80	16400	20	30	30	3.60	12300	17.3	27	30
BAYHTR1408+++	1/1	7.68	26200	32	45	45	5.76	19700	27.7	39	40
BAYHTR1410+++	1/1	9.60	32800	40	55	60	7.20	24600	34.6	48	50
BAYHTR3410 000	1/3	9.60	32800	34.6	43	45	7.20	24600	30	37	40
BAYHTR1415 BRK	2/1	15.36	52400	40/24	55*/30	60*/30	11.53	39300	34.6/20.8	48*/26	50*/30
BAYHTR3415 000	1/3	15.36	52400	38.2	52	60	11.53	39300	33.1	45	45

* Circuit 1/Circuit 2 (Minimum Circuit Ampacity for Circuit 1 includes Blower Motor Amp
+++ = 000, PDC, BRK 000 = pigtails, PDC= contains pull disconnect, BRK=contains Circuit disconnects
IMPORTANT: Any power supply and/or combination power supply, circuit or circuits must be wired and protected in accordance with local Electrical Codes.

2/4TGB3F48A1000A WIRING DATA Indoor Blower Motor Powered from Heater Circuit 1											
Heater Model No.	Number of Circuits/Phase	240 VOLT					208 VOLT				
		Capacity		Heater Amps per Circuit	Minimum Circuit Ampacity	Maximum Overload Protection	Capacity		Heater Amps per Circuit	Minimum Circuit Ampacity	Maximum Overload Protection
		KW	BTUH				KW	BTUH			
No Heater	-	-	-	-	5	15	-	-	-	5	15
BAYHTR1405+++	1/1	4.80	16400	20	29	30	3.60	12300	17.3	26	30
BAYHTR1408+++	1/1	7.68	26200	32	44	45	5.77	19700	27.7	39	40
BAYHTR1410+++	1/1	9.60	32800	40	54	60	7.20	24600	34.6	48	50
BAYHTR3410 000	1/3	9.60	32800	34.6	43	45	7.20	24600	30	37	40
BAYHTR1415 BRK	2/1	15.36	52400	40/24	54*/30	60*/30	11.53	39300	34.6/20.8	48*/26	50*/30
BAYHTR3415 000	1/3	15.36	52400	41.1	51	60	11.53	39300	36	45	45
BAYHTR1419 BRK	2/1	19.20	65500	32/48	44*/60	45*/60	14.42	49200	27.7/41.6	39*/52	40*/60

* Circuit 1/Circuit 2 (Minimum Circuit Ampacity for Circuit 1 includes Blower Motor Amp
+++ = 000, PDC, BRK 000 = pigtails, PDC= contains pull disconnect, BRK=contains Circuit disconnects
IMPORTANT: Any power supply and/or combination power supply, circuit or circuits must be wired and protected in accordance with local Electrical Codes.



Wiring Diagram

WIRING DIAGRAM FOR 2/4TGB3F18,25,30,36A1000A

⚠ WARNING

HAZARDOUS VOLTAGE!
DISCONNECT ALL ELECTRICAL POWER INCLUDING REMOTE DISCONNECTS BEFORE SERVICING.
Failure to disconnect power before servicing can cause severe personal injury or death.

⚠ CAUTION

USE COPPER CONDUCTORS ONLY!
UNIT TERMINALS ARE NOT DESIGNED TO ACCEPT OTHER TYPES OF CONDUCTORS.
Failure to do so may cause damage to the equipment.

AIR FLOW SELECTION	
TERM	SPEED
A	LOW
B	MED
C	HIGH

LEGEND

- 24 V.
- LINE V.
- ⊥ GROUND
- JUNCTION
- ⊢ CAPACITOR
- △ WIRE CONNECTOR
- TERMINAL
- ⊞ TRANSFORMER
- ⊞ FUSE
- ⊢ RELAY CONTACT NO
- ⊞ MAGNETIC COIL
- ⊞ POL. PLUG FEMALE (MALE TERMINALS)
- ⊞ POL. PLUG MALE (FEMALE TERMINALS)
- CN WIRE CONNECTOR
- CF FAN CAPACITOR
- F FAN RELAY
- FU FUSE
- PCB PRINTED CIRCUIT BOARD
- PF POLARIZED PLUG (FEMALE HOUSING)
- PM POLARIZED PLUG (MALE HOUSING)
- TNS TRANSFORMER
- COLOR OF WIRE
- BK/BL BLACK WIRE WITH BLUE MARKER
- COLOR OF MARKER
- BK BLACK RD RED OR ORANGE
- BL BLUE WH WHITE GR GREEN
- BR BROWN YL YELLOW PR PURPLE

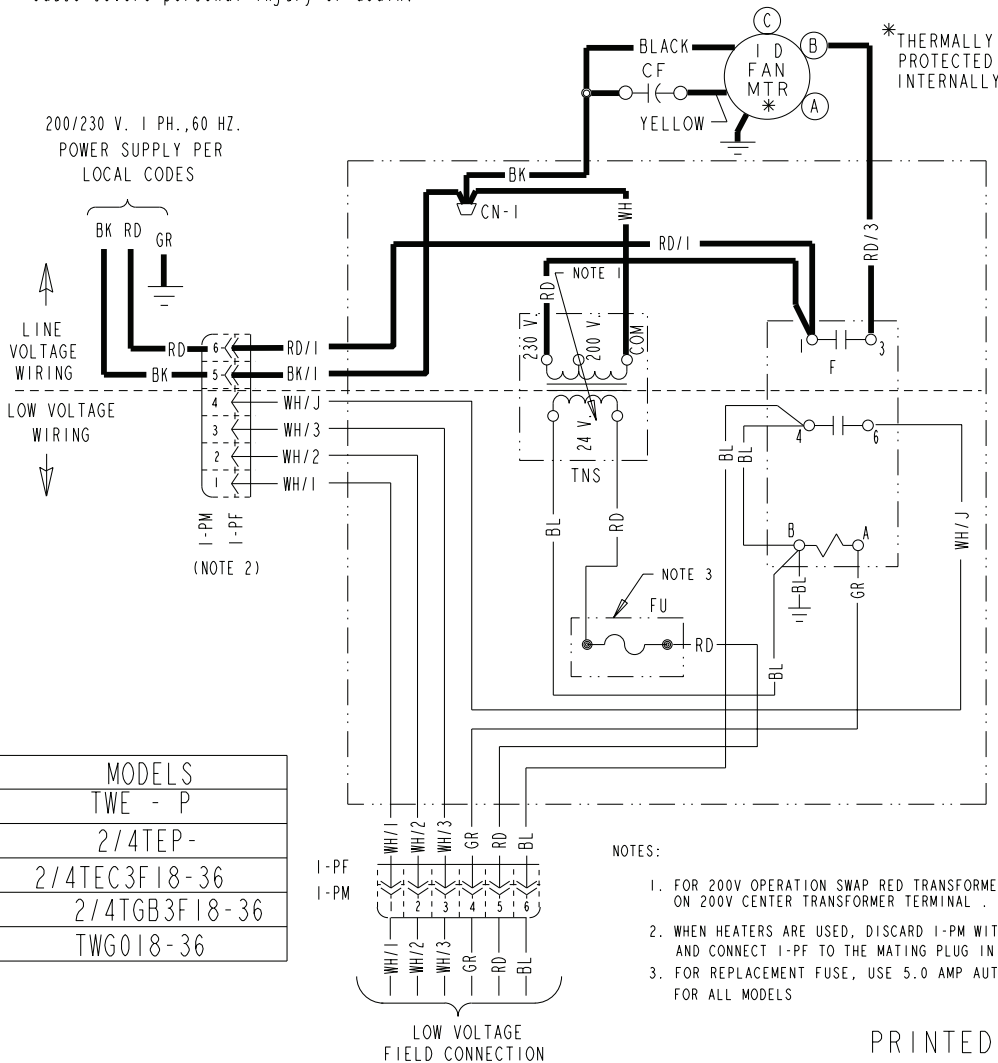

NOTES:

- FOR 200V OPERATION SWAP RED TRANSFORMER LEAD AND INSULATED CAP ON 200V CENTER TRANSFORMER TERMINAL.
- WHEN HEATERS ARE USED, DISCARD 1-PM WITH ATTACHED LEADS AND CONNECT 1-PF TO THE MATING PLUG IN THE HEATER CONTROL BOX.
- FOR REPLACEMENT FUSE, USE 5.0 AMP AUTOMOTIVE STYLE FOR ALL MODELS

PRINTED FROM C800722P01 REV13

Wiring Diagram

WIRING DIAGRAM FOR 2/4TGB3F42,48A1000A

WARNING

HAZARDOUS VOLTAGE!
DISCONNECT ALL ELECTRICAL POWER INCLUDING REMOTE DISCONNECTS BEFORE SERVICING.
Failure to disconnect power before servicing can cause severe personal injury or death.

CAUTION

USE COPPER CONDUCTORS ONLY!
UNIT TERMINALS ARE NOT DESIGNED TO ACCEPT OTHER TYPES OF CONDUCTORS.
Failure to do so may cause damage to the equipment.

LEGEND

- 24 V.
- LINE V.
- ⊥ GROUND
- JUNCTION
- ⊢ CAPACITOR
- △ WIRE CONNECTOR
- TERMINAL
- ⊞ TRANSFORMER
- ⊞ FUSE
- ⊢ RELAY CONTACT NO
- ⊞ MAGNETIC COIL
- ⊞ POL. PLUG FEMALE (MALE TERMINALS)
- ⊞ POL. PLUG MALE (FEMALE TERMINALS)
- CN WIRE CONNECTOR
- CF FAN CAPACITOR
- F FAN RELAY
- FU FUSE
- PCB PRINTED CIRCUIT BOARD
- PF POLARIZED PLUG (FEMALE HOUSING)
- PM POLARIZED PLUG (MALE HOUSING)
- TNS TRANSFORMER
- ↔ COLOR OF WIRE
- ↔ BLACK WIRE WITH BLUE MARKER
- ↔ COLOR OF MARKER
- BK BLACK RD RED OR ORANGE
- BL BLUE WH WHITE GR GREEN
- BR BROWN YL YELLOW PR PURPLE

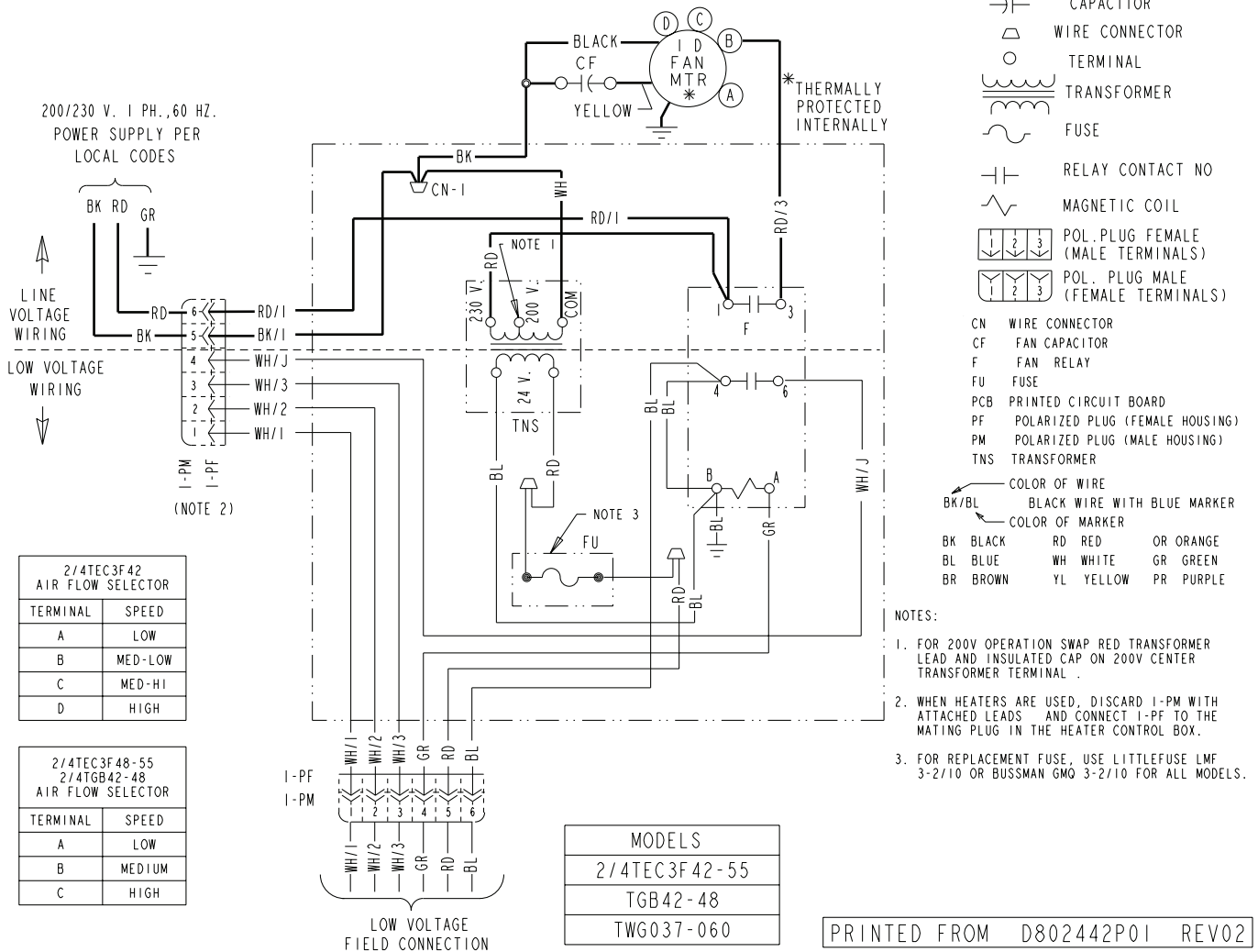

2/4TEC3F42 AIR FLOW SELECTOR	
TERMINAL	SPEED
A	LOW
B	MED-LOW
C	MED-HI
D	HIGH

2/4TEC3F48-55 2/4TGB42-48 AIR FLOW SELECTOR	
TERMINAL	SPEED
A	LOW
B	MEDIUM
C	HIGH

- NOTES:
- FOR 200V OPERATION SWAP RED TRANSFORMER LEAD AND INSULATED CAP ON 200V CENTER TRANSFORMER TERMINAL.
 - WHEN HEATERS ARE USED, DISCARD I-PM WITH ATTACHED LEADS AND CONNECT I-PF TO THE MATING PLUG IN THE HEATER CONTROL BOX.
 - FOR REPLACEMENT FUSE, USE LITTLEFUSE LMF 3-2/10 OR BUSSMAN GMD 3-2/10 FOR ALL MODELS.

Field Wiring

2/4TGB AIR HANDLERS WITH SINGLE STAGE COOLING, 1 STAGE HEAT

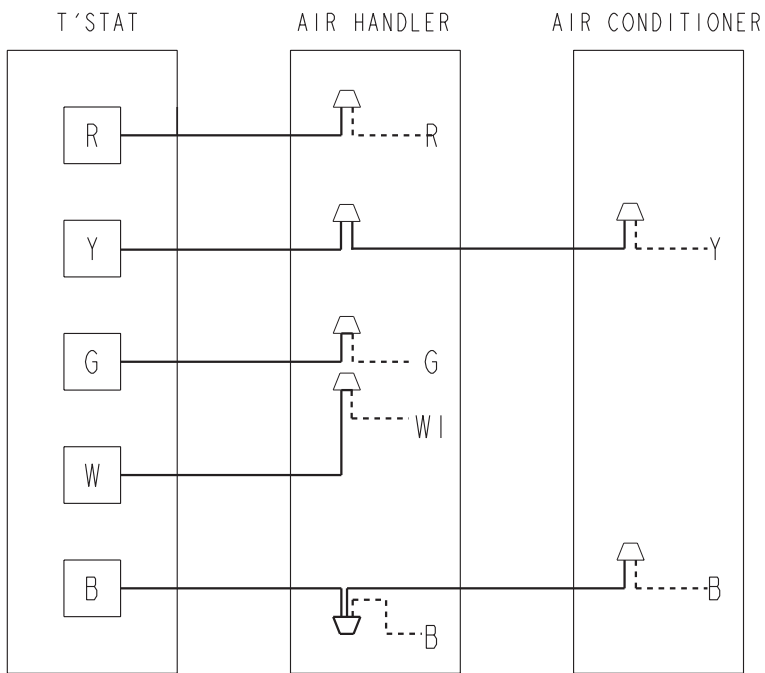

1. BE SURE POWER SUPPLY AGREES WITH EQUIPMENT NAMEPLATE.
2. POWER WIRING AND GROUNDING OF EQUIPMENT MUST COMPLY WITH LOCAL CODES.
3. LOW VOLTAGE WIRING TO BE NO. 18 AWG MINIMUM CONDUCTOR.

24V INTER-COMPONENT WIRING

----- (FACTORY) (FIELD)
 (WIRING) (WIRING)

PRINTED FROM B800978P01

Field Wiring

2/4TGB AIR HANDLERS WITH SINGLE SPEED HEAT PUMP

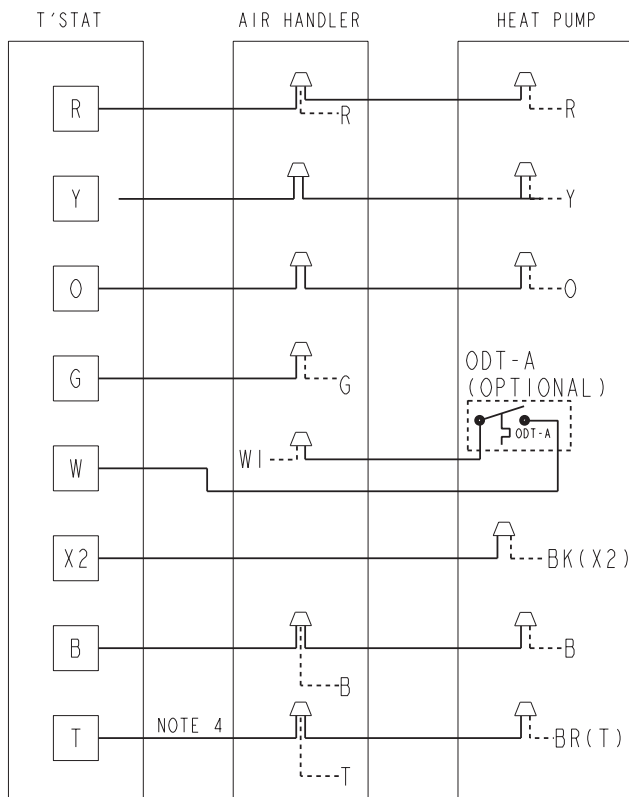

PRINTED FROM B800980P01

NOTES:

1. BE SURE POWER SUPPLY AGREES WITH EQUIPMENT NAMEPLATE.
2. POWER WIRING AND GROUNDING OF EQUIPMENT MUST COMPLY WITH LOCAL CODES.
3. LOW VOLTAGE WIRING TO BE NO. 18 AWG MINIMUM CONDUCTOR.
4. N/A TO PROGRAMMABLE THERMOSTAT.

24V INTER-COMPONENT WIRING

--- (FACTORY) (WIRING) — (FIELD) (WIRING)

Field Wiring

2/4TGB AIR HANDLERS WITH SINGLE STAGE COOLING AND TWO STAGE HEATING

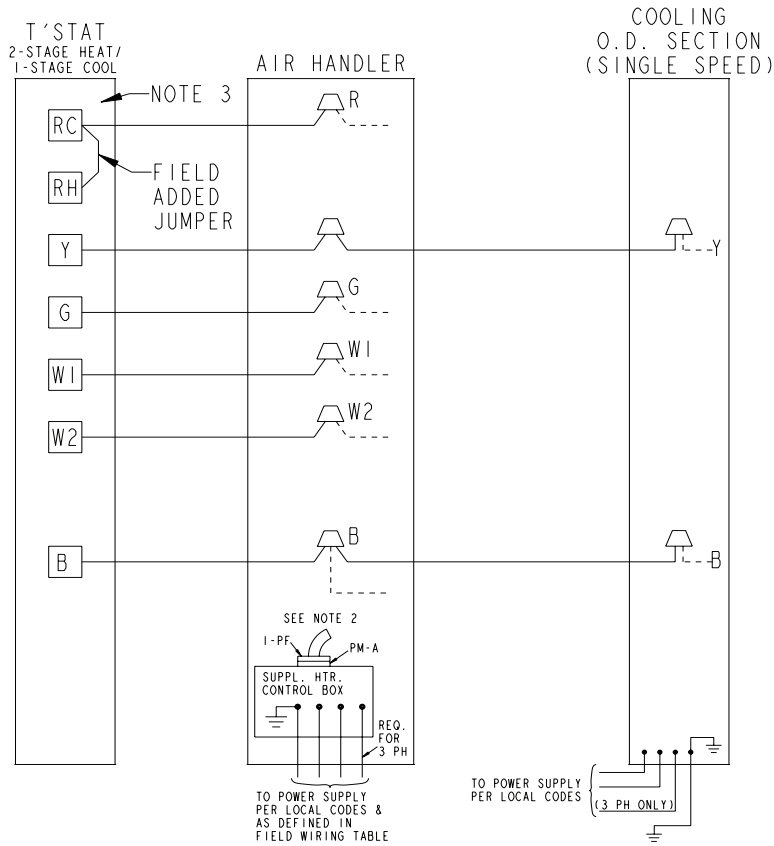

NOTES:

1. LOW VOLTAGE WIRING TO BE NO. 18 A.W.G. MINIMUM CONDUCTOR.
2. WHEN FIELD-INSTALLED HEATERS ARE USED, DISCARD POWER LEADS WITH POLARIZED PLUG PM-A AND CONNECT I-PF TO MATING PLUG IN THE HEATER CONTROL BOX AS SHOWN.
3. SEE HEATER WIRING DIAGRAM FOR HEATING ANTICIPATOR SETTING.

From Dwg. B801081 Rev. 2

Outline Drawing

OUTLINE DRAWING FOR 2/4TGB3F18,25,30,36A

MINIMUM UNIT CLEARANCE TABLE		SERVICE CLEARANCE (RECOMMENDED)	
SIDES	0"	2'	
FRONT	0"	2'	
BACK	0"	0"	
INLET DUCT	0"	0"	
OUTLET DUCT	1"	1'	

1" FOR THE FIRST 3 FT. OF OUTLET DUCT WHEN ELECTRIC HEATERS ARE INSTALLED, EXCEPT MODELS BARRH1405, 1408, AND 1410 ARE APPLIED. # 1" IS THE MINIMUM DUCT CLEARANCE IN THE OFFFLOW CONFIGURATION ONLY.

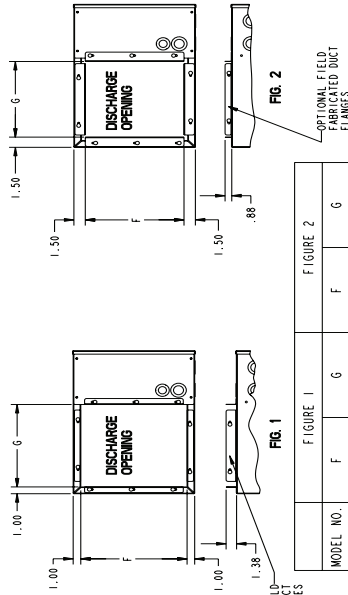
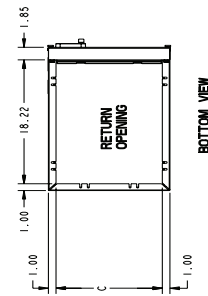
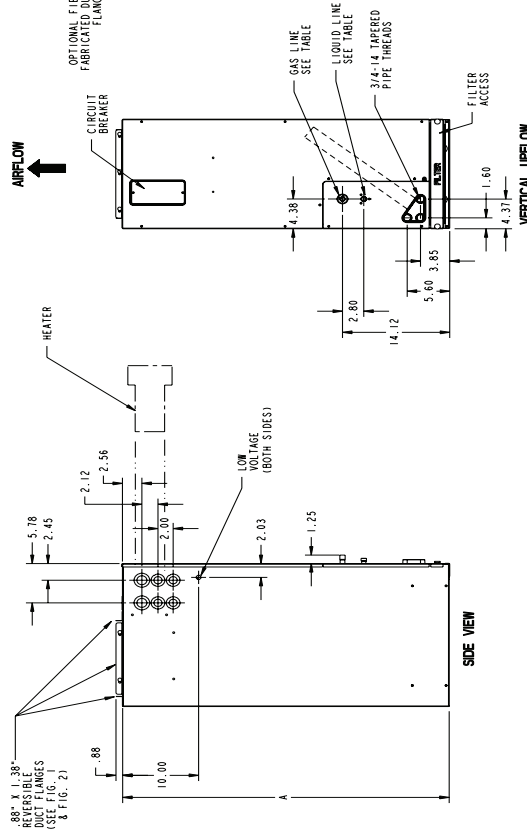
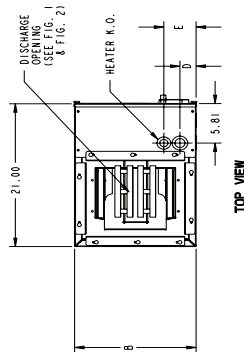

MODEL NO.	FIGURE 1			FIGURE 2		
	F	G	G	F	F	G
TW6018A	14.00	12.12	13.00	11.12		
TW6025A	16.00	12.12	15.00	11.12		
TW6030A	16.00	12.12	15.00	11.12		
TW6036A	16.00	12.12	15.00	11.12		
2/4TGB-18	16.00	12.12	15.00	11.12		
2/4TGB-25	16.00	12.12	15.00	11.12		
2/4TGB-30	16.00	12.12	15.00	11.12		
2/4TGB-36	16.00	12.12	15.00	11.12		

MODEL NO.	A	B	C	D	E	FLOW CONTROL	GAS LINE SIZE	LIQUID LINE SIZE
TW6018A	43.00	16.00	14.00	2.13	4.25	FCCV	5/8 BRAZE	1/4 BRAZE
TW6025A	45.70	18.00	16.00	3.13	5.25	FCCV	3/4 BRAZE	5/16 BRAZE
TW6030A	45.70	18.00	16.00	3.13	5.25	FCCV	3/4 BRAZE	5/16 BRAZE
TW6036A	52.00	18.00	16.00	3.13	5.25	FCCV	7/8 BRAZE	3/8 BRAZE
2TGB-18	45.70	18.00	16.00	3.13	5.25	TXV	5/8 BRAZE	1/4 BRAZE
2TGB-25	45.70	18.00	16.00	3.13	5.25	TXV	3/4 BRAZE	5/16 BRAZE
2TGB-30	52.00	18.00	16.00	3.13	5.25	TXV	3/4 BRAZE	5/16 BRAZE
2TGB-36	52.00	18.00	16.00	3.13	5.25	TXV	7/8 BRAZE	3/8 BRAZE
4TGB-18	45.70	18.00	16.00	3.13	5.25	TXV	1/2 BRAZE	3/8 BRAZE
4TGB-25	45.70	18.00	16.00	3.13	5.25	TXV	5/8 BRAZE	3/8 BRAZE
4TGB-30	52.00	18.00	16.00	3.13	5.25	TXV	3/4 BRAZE	3/8 BRAZE
4TGB-36	52.00	18.00	16.00	3.13	5.25	TXV	3/4 BRAZE	3/8 BRAZE

HORIZ LEFT

METRIC CONVERSION
INCHES X 25.4 MM

D810094REV05



Mechanical Specification Options

Features and General Information

These blower coil units are completely factory assembled including coil, condensate drain pan, fan, motor, filters and controls in an insulated casing that can be applied in horizontal left or vertical upflow configuration. This model has 4.2 "R" value insulation and additional sealing systems.

The unit ships in the upflow configuration and converts to left-hand horizontal by laying the unit on its side. No tools required.

Casing

These models have a rugged galvanized sheet metal and steel frame construction. The casing is painted with an enamel finish. The casing is insulated and provides knockouts for electrical power and control wiring.

Refrigerant Circuits

The TGB units have a single refrigerant circuit. The refrigerant circuit is controlled by a factory installed non-bleed thermal expansion valve.

Coil

Aluminum fin surface is mechanically bonded to 3/8 inch OD copper tubing. Coils are factory pressure and leak tested.

Fan

The blower housing is forward curved, dynamically balanced with a speed direct drive fan motor. The fan motor is permanently lubricated.

Controls

Low voltage fan contactor, and plug-in module for accessory electric heat control is included.

Filters

The TGB018A through TGB048A have standard size filters.

Electric Heaters

Heaters for the TGB air handlers are available in a wide range of capacities and voltages with various staging options, and plug-in control wiring. Heaters fit inside the internal compartment.



Trane
6200 Troup Highway
Tyler, TX 75707
www.trane.com

For more information contact your local dealer (distributor)

01/09

Trane has a policy of continuous product and product data improvement, it reserves the right to change design and specifications without notice.