



**TRANE™**

**Installation  
Operation  
Maintenance**

**CGA-IOM-4C**

Library	Service Literature
Product Section	Refrigeration
Product	Scroll Liquid Chillers - A/C Cold Generators
Model	CGA
Literature Type	Installation, Operation & Maintenance
Sequence	4C
Date	January 2004
File No.	SV-RF-CG-CGA-IOM-4C 01/04
Supersedes	CGA-IOM-4C 05/03

**10 and 15 Ton  
Air-Cooled Cold Generator™**

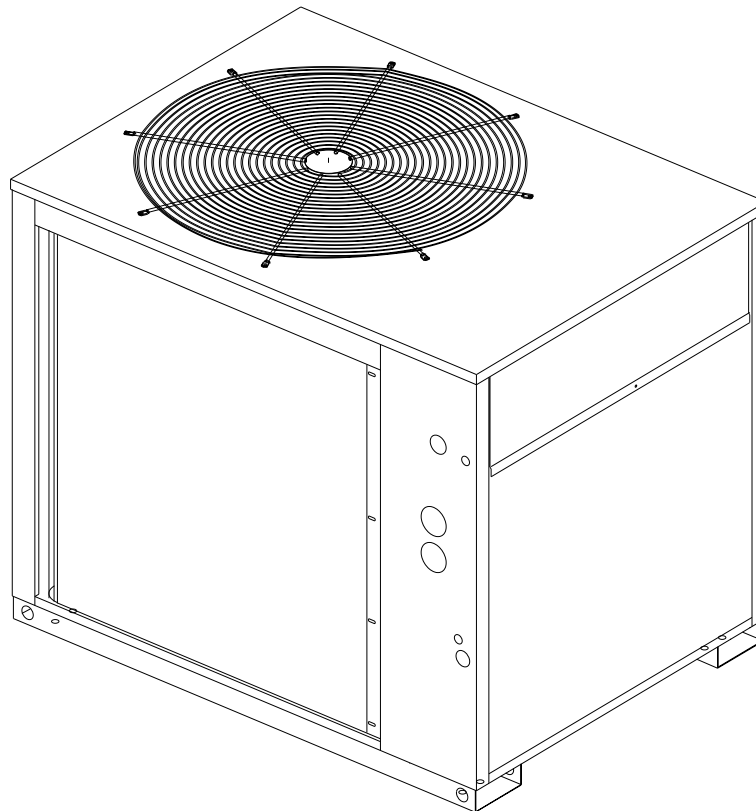

**Models**

- CGA 100 BD \_ \_ F \_
- CGA 120 B \_ \_ F \_
- CGA 150 BD \_ \_ E \_
- CGA 180 B \_ \_ E \_

**Note: The installation of this equipment must comply with all National, State and Local Codes.**

Since the manufacturer has a policy of continuous product improvement, it reserves the right to change specifications and design without notice.

# About the Manual

---

## Literature Change History

### **CGA-IOM-4A (January 2002)**

First issue of manual; provides Installation, Operation, and Maintenance instructions for CGA 120B---E and CGA 180B---D (See digit 11)

### **CGA-IOM-4B (February 2003)**

10 ton Compressor Change

### **CGA-IOM-4C (May 2003)**

15 ton Compressor Change

### **CGA-IOM-4C (January 2004)**

Compressor LRA updates. Added 50 Hz data.

## Overview of Manual

---

***Note: One copy of this document ships inside the control panel of each unit and is customer property. It must be retained by the unit's maintenance personnel.***

---

This booklet describes proper installation, operation, and maintenance procedures for air cooled systems. By carefully reviewing the information within this manual and following the instructions, the risk of improper operation and/or component damage will be minimized.

It is important that periodic maintenance be performed to help assure trouble free operation. A maintenance schedule is provided in this manual. Should equipment failure occur, contact a qualified service organization with qualified, experienced HVAC technicians to properly diagnose and repair this equipment.

---

***Note: The procedures discussed in this manual should only be performed by qualified, experienced HVAC technicians. Do Not release refrigerant to the atmosphere! If adding or removing refrigerant is required, the service technician must comply with all federal, state, and local laws.***

---

# Table of Contents

---

## About the Manual

Literature Change History .....	2
Overview of Manual .....	2

## General Information

Model Number Description .....	4
General Information .....	5
Hazard Identification .....	5

## Installation

Unit Dimensions and Weights .....	6
Unit Water Piping .....	9
Freeze Protection .....	10
Heat Tape Selection .....	11
Electrical Data .....	11
Minimum Starting Ambient Temperature .....	12
Control Settings and Time Delays .....	12
Electrical Wiring .....	13

## Installation Checklist

Unit Location and mounting .....	14
Field Installed Accessories .....	14

## Pre-Start Procedures

Pre-Start Checklist .....	15
Voltage Supply .....	16
Voltage Imbalance .....	16
Pressure Drop Measurements .....	16
Normal Operating Pressures .....	17
Ethylene Glycol Performance .....	17

## Start-Up

Start-Up Procedure .....	18
Refrigerant Charge Information .....	19
Temporary Unit Shutdown and Restart .....	19
System Restart	
After Extended Shutdown .....	20
Extended Shutdown/Winterization .....	20
Low Ambient Operation .....	20
Electrical Control System .....	21
Unit Safety Controls: .....	21
Unit Operational Controls .....	22
Unit Control System .....	22
Determining the setpoint for the	
Water Temperature Thermostat (WTT) .....	23
Unit Control Panel Layout .....	25

## Maintenance

Refrigerant Schematic- CGA120 .....	26
Refrigerant Schematic- CGA180 .....	27
Periodic Maintenance .....	28
Weekly Maintenance .....	28
Monthly Maintenance .....	28
Annual Maintenance .....	28
Maintenance Procedures .....	29
Low Ambient Start Timer	
(LAST) Checkout Procedure .....	30

## System Troubleshooting

Preliminary Troubleshooting Inspection .....	31
Troubleshooting Charts .....	31
Operator's Maintenance Log .....	35

# General Information

## Model Number Description

All Trane products are identified by a multiple-character model number that precisely identifies a particular type of unit. An explanation of the alphanumeric identification code is provided below. Its use will enable the owner/operator, installing contractors, and service engineers to define the operation, specific components, and other options for any specific unit.

When ordering replacement parts or requesting service, be sure to refer to the specific model number, serial number, and DL number (if applicable) stamped on the unit nameplate.

**Sample Model Number:** CGA-120B300EA  
**Digit Number:** 1,2,3, 4 5,6, 7 8 9 10 11 12

**Digit 1, 2, 3**  
 CGA = Cold Generator

**Digit 4, 5, 6**  
**Nominal Capacity (Mbh)**  
 120 = 10 Tons  
 180 = 15 Tons

**Digit 7**  
**Form on Configuration**  
**(Number of Refrigerant Circuits/  
 Number of Compressors)**  
 B = 2 Ref. Ckts/2 Compr.

**Digit 8**  
**Voltage**  
 1 = 208-230V/60 Hz/1\*  
 3 = 208-230V/60 Hz/3  
 4 = 460/60 Hz/3  
 W = 575V/60 Hz/3  
 D = 380-415V/50 Hz/3

**Digit 9**  
**Factory Installed Options**  
 O = No Options  
 H = Hot Gas Bypass  
 C = Chromate Coil  
 K = Hot Gas Bypass and Chromate Coil

**Digit 10**  
**Expansion Valve**  
 O = Standard Expansion Valve  
 V = Low Leaving Solution Temp Expansion Valve

**Digit 11**  
**Major Design Change**  
 E

**Digit 12**  
 Service Digit/Minor Design Change

Note: The unit nameplate is located adjacent to the high voltage access hole near the control panel. The service data plate is located inside the control box.

\* Available - CGA120 ONLY

AMERICAN STANDARD INC. THE TRANE CO. <b>Odyssey™</b> CULLEN, LA. 71021					
MODEL NO.	MFG. DATE				
SERIAL NO.	VOLT	PH	HZ		
UNIT RATED POWER					
MAX. FUSE (AMPS)	VOLT		PH	MIN. CKT. AMP. (AMPS)	
				RLA	LRA
COMPR MOTOR 1	QTY	PH	HZ	FLA	HP
COMPR MOTOR 2					
COND FAN MTR (S)			VOLTS	PH	VA
POWER REQUIREMENTS FOR EVAPORATOR HEAT TAPE					
FACTORY CHARGED R22 REFRIGERANT	(CKT. 1)		(CKT. 2)		
	LB	OZ	LB	OZ	
TEST PRESSURE	PSIG HIGH		PSIG LOW		
SUITABLE FOR OUTDOOR USE					
MAXIMUM CIRCUIT BREAKER SIZE CANADIAN INSTALLATION (CSA) ONLY					AMPS
ASSEMBLED IN USA					
D932276P01					

MOD. NO.	MFG. DATE				
SERIAL NO.					
REFRIGERANT 22	"A" CPR	LBS		OZ	
FACTORY CHARGE	"B" CPR	LBS		OZ	
D932276P02					

# General Information

---

## Hazard Identification

"Warnings" and "Cautions" appear at appropriate points in this manual. Cautions indicate areas where special attention is required to prevent equipment or property damage. Warnings focus attention on the personal safety of installing and operating personnel. The instructions given in each warning that appears in this manual must be followed carefully.

**▲ WARNING:** Warnings are provided throughout this manual to indicate to installing contractors, operators, and service personnel of potentially hazardous situations which, if not avoided, COULD result in death or serious injury.

**▲ CAUTION:** Cautions are provided throughout this manual to indicate to installing contractors, operators, and service personnel of potentially hazardous situations which, if not avoided, MAY result in minor or moderate injury.

## Installation Checklist

An Installation Checklist is provided at the end of the "Installation" section of this manual. Use the checklist to verify that all necessary installation procedures have been completed. Do not use the checklist as a substitute for reading the detailed information contained in the manual. Read the entire manual before beginning installation procedures.

## Unit Description

10 and 15-ton Model CGA air-cooled Cold Generators are designed for outdoor installation with a vertical air discharge. Each refrigerant circuit is provided with an operating charge of refrigerant and refrigerant oil, a filter drier, sight glass or moisture indicator and a thermostatic expansion valve. All units are dehydrated, leak tested, charged and tested for proper control operation before shipment.

An access panel(s) provides access to the compressor section(s), and a removable cover allows access to the control box.

A bag containing the installation/operation/maintenance manual and the unit wiring diagrams ships inside the unit control box. Be sure to read this literature before installing and operating the unit. See to Figures 2 and 3 for unit access panel locations and other exterior components.

## Unit Inspection

When the unit is delivered to the job site, verify that the correct unit has been shipped by comparing the information on the unit nameplate with ordering, submittal and shipping information. Refer to the "Nameplates" section.

Inspect the unit on the inside and on the outside for damage. Rotate the condenser fan(s) to ensure that they turn freely. Report any apparent damage or material shortage to the carrier and make a "unit damage or shortage" notation on the carrier's delivery receipt. Specify the extent and type of damage found, and notify the appropriate Trane sales office. Do not proceed with installation of a damaged unit without sales office approval.

## Inspection Checklist

To protect against loss due to damage incurred in transit, complete the following checklist upon receipt of the unit:

[ ] Inspect individual pieces of the shipment before accepting the unit. Check for obvious damage to the unit or packing material

[ ] Check the unit for concealed damage before it is stored and as soon as possible after delivery. Concealed damage must be reported within 15 days.

[ ] If concealed damage is discovered, stop unpacking the shipment. Do not remove damage material from the receiving location. Take photos of the damage, if possible. The owner must provide reasonable evidence that the damage did not occur after delivery.

[ ] Notify the carrier's terminal of damage immediately by phone and by mail. Request an immediate joint inspection of the damage by the carrier and the consignee.

[ ] Notify the Trane representative and arrange for repair. Do not repair the unit, however, until damage is inspected by the carrier's representative.

## Nameplates

The nameplates on these units provide valuable information pertaining to the identification of the unit and its components. Be sure to provide all pertinent nameplate data when ordering parts or literature, and when making other inquiries.

## Unit Nameplate

The CGA unit nameplate is mounted on the front of the unit, at the compressor end. This nameplate (shown in Figure 1) specifies unit model number, serial number, electrical characteristics, heat tape power requirements and refrigerant charge information.

# Installation

Complete the "Installation Checklist" during installation to verify completion of all recommended procedures before unit start-up.

## Unit Dimensions and Weights

CGA-10 and -15 unit dimensions and weights are provided in Figures 2 and 3 and in Table 1.

### Handling

Each CGA unit is banded to a shipping skid for shipment to the job site. Move the unit using a forklift of suitable capacity. See Table 1 for the unit shipping weights.

---

## **WARNING:**

**To avoid possible injury or unit damage, do not remove the unit from its shipping skid until it is at the installation site.**

---

### Drainage

Locate the unit near a large-capacity drain to allow system drainage during unit shutdown and repair.

### Rigging

Use a forklift, crane or helicopter of suitable capacity to move the unit to its mounting location. Unit shipping weights are provided in Table 1.

**Table 1  
Unit Weights**

Model No	Approx. Corner Weight (lbs) 1				Net Weight (lbs)	Shipping Weight (lbs)
	#1	#2	#3	#4		
CGA 100B	161	164	103	101	529	576
CGA 120B	161	164	103	101	529	576
CGA 150B	186	187	208	207	788	871
CGA 180B	186	187	208	207	788	871

Note: Corner weights include weight of water in the evaporator.

---

## **WARNING:**

### **LIFTING AND MOVING INSTRUCTIONS!**

**DO NOT USE CABLES (CHAINS OR SLINGS) EXCEPT AS SHOWN. OTHER LIFTING ARRANGEMENTS MAY CAUSE EQUIPMENT DAMAGE OR SERIOUS PERSONAL INJURY.**

**EACH OF THE CABLES (CHAINS OR SLINGS) USED TO LIFT UNIT MUST BE CAPABLE OF SUPPORTING THE ENTIRE WEIGHT OF THE UNIT.**

**LIFTING CHAINS (CABLES OR SLINGS) MAY NOT BE THE SAME LENGTH. ADJUST AS NECESSARY FOR EVEN LEVEL LIFT.**

---

Rig the unit using either belt or cable slings. Fasten the slings to the unit at the four holes provided in the unit's base. Use spreaders to protect the top of the unit when it is lifted. The point at which the slings meet at the lifting hook must be at least 6 feet above the unit. Test-lift the unit to ensure proper balance and rigging.

### Location and Clearance Requirements

Select an installation site where air flow upward, unobstructed, through the condenser coil and away from the fan discharge. Protect the unit's condenser intakes from crosswinds exceeding 5 mph. Position the unit above the snowline, and above the path of any windblown debris. Refer to Figures 2 and 3 for clearances.

**CAUTION: Do not install the unit under an overhang, since obstructing vertical air discharge will cause recirculation of warm air.**

If the unit is installed in a well or pit, the height of the pit walls must not exceed the height of the unit; the normal condenser air clearances must be doubled as well. In those applications where multiple units are installed, the minimum distance between each unit is 6 feet, (entire perimeter).

### Unit Isolation

Mounting methods that will minimize sound and vibration problems are:

1. Mount the unit directly on an isolated concrete pad or on isolated concrete footings at each unit mounting point.
2. Install the optional neoprene spring isolators at each mounting location. Refer to the appropriate isolator installer's guide for installation.

**Figure 2**  
**CGA100B / CGA120B Unit**  
**(10 Ton)**

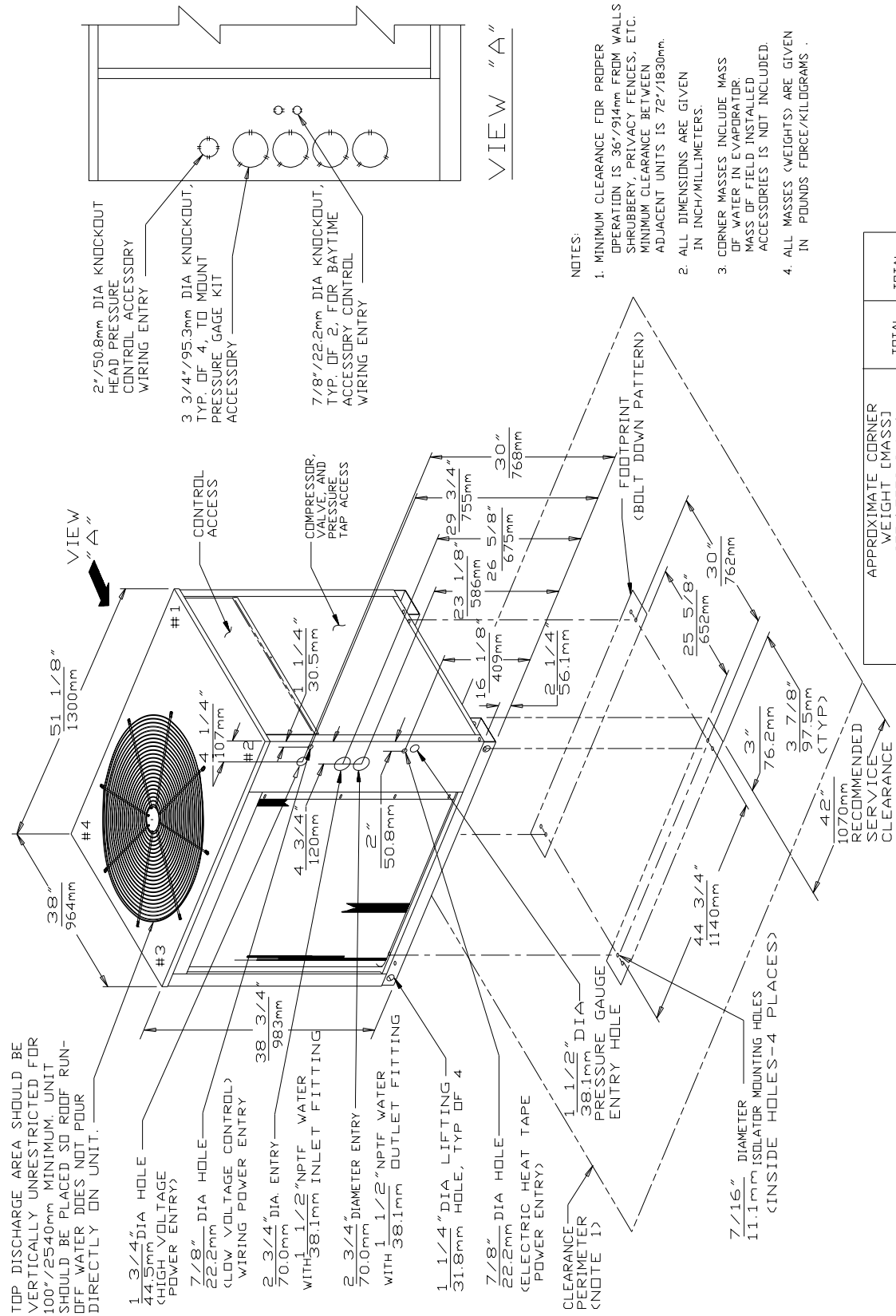

- NOTES:**
1. MINIMUM CLEARANCE FOR PROPER OPERATION IS 36"/914mm FROM WALLS SHRUBBERY, PRIVACY FENCES, ETC. MINIMUM CLEARANCE BETWEEN ADJACENT UNITS IS 72"/1830mm.
  2. ALL DIMENSIONS ARE GIVEN IN INCH/MILLIMETERS.
  3. CORNER MASSES INCLUDE MASS OF WATER IN EVAPORATOR. MASS OF FIELD INSTALLED ACCESSORIES IS NOT INCLUDED.
  4. ALL MASSES (WEIGHTS) ARE GIVEN IN POUNDS FORCE/KILOGRAMS.

MODEL NO	APPROXIMATE CORNER WEIGHT [MASS] (SEE NOTES 3 & 4)				TOTAL SHIPPING WEIGHT	TOTAL NET WEIGHT
	#1	#2	#3	#4		
CGA100B-E, F	161 lb 73 kg	164 lb 74.4 kg	103 lb 46.7 kg	101 lb 45.8 kg	576 lb 261.3 kg	240 kg
CGA120B-E, F					576 lb 261.3 kg	

D669843

**Figure 3**  
**CGA150B / CGA180B Unit**  
**(15 Ton)**

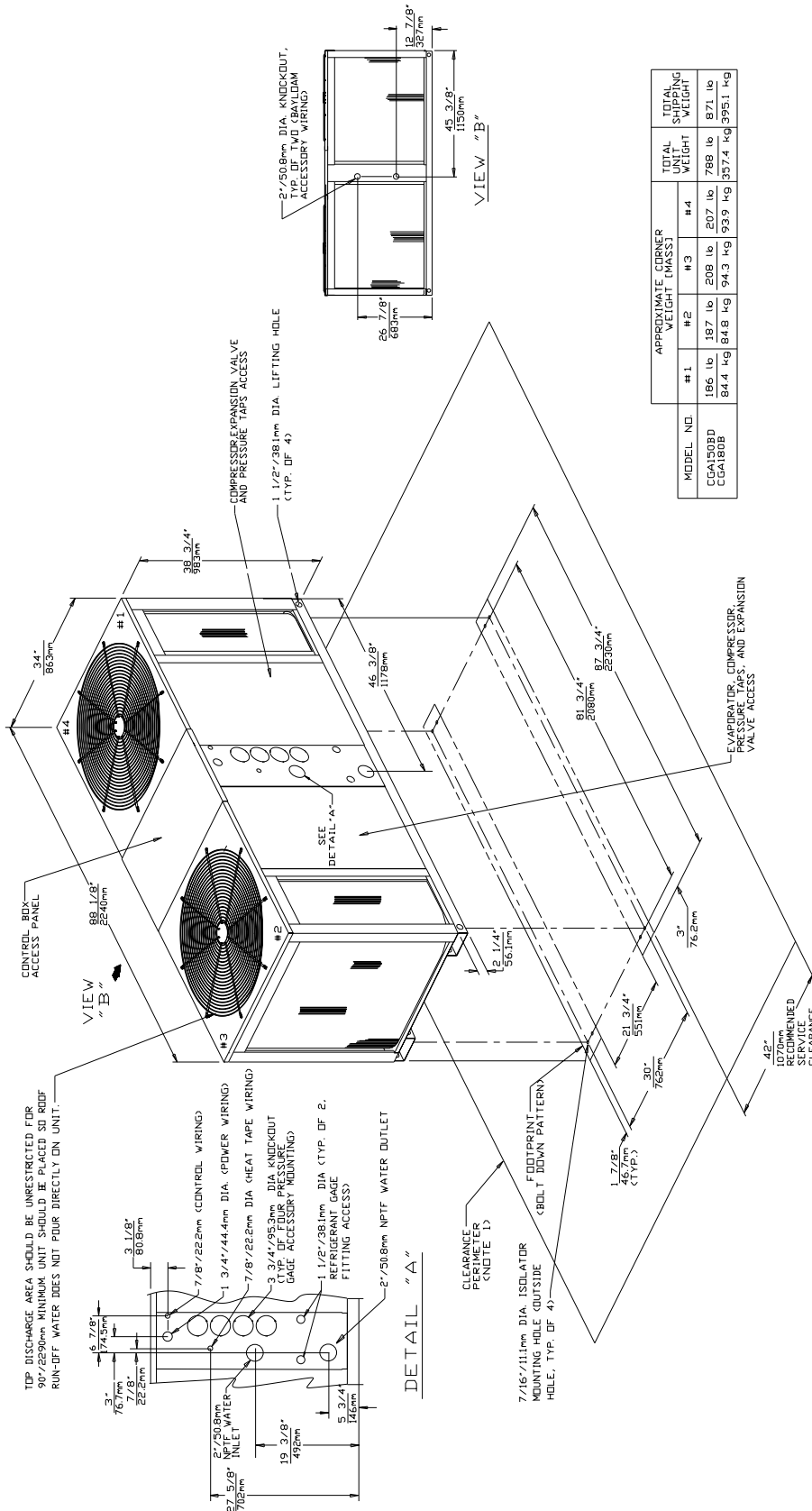

MODEL NO.	APPROXIMATE CORNER WEIGHT (MASS)				TOTAL UNIT WEIGHT	TOTAL UNIT WEIGHT
	#1	#2	#3	#4		
CGA150B	186 lb	208 lb	207 lb	207 lb	788 lb	871 lb
CGA180B	84.4 kg	84.8 kg	94.3 kg	93.9 kg	357.4 kg	395.1 kg

D469834

# Installation

## Unit Water Piping

### General Piping Recommendations

Thoroughly flush all water supply piping **before** making the final piping connections to the unit.

---

### ▲ CAUTION:

If using an acidic commercial flushing solution, construct a temporary bypass around the unit to prevent damage to the evaporator's internal components.

---

### ▲ CAUTION:

To avoid possible equipment damage, do not use untreated - or improperly treated - system water.

---

Refer to the "Trane Reciprocating Refrigeration Manual" for a complete discussion of proper piping practices and sizing methods. This manual is available through local Trane sales offices.

### Evaporator Water Piping

The unit's water connection sizes and locations are shown in Figures 2 and 3.

---

### ▲ CAUTION:

To prevent unit damage, do NOT reverse system water piping connections to the unit; water entering the evaporator must enter at the designated "Water Inlet," and leaving water must exit the evaporator through the designated "Water Outlet" connection.

---

**Figure 4**

**Recommended Piping Components For Typical Evaporator Installation (10 Ton unit shown)**

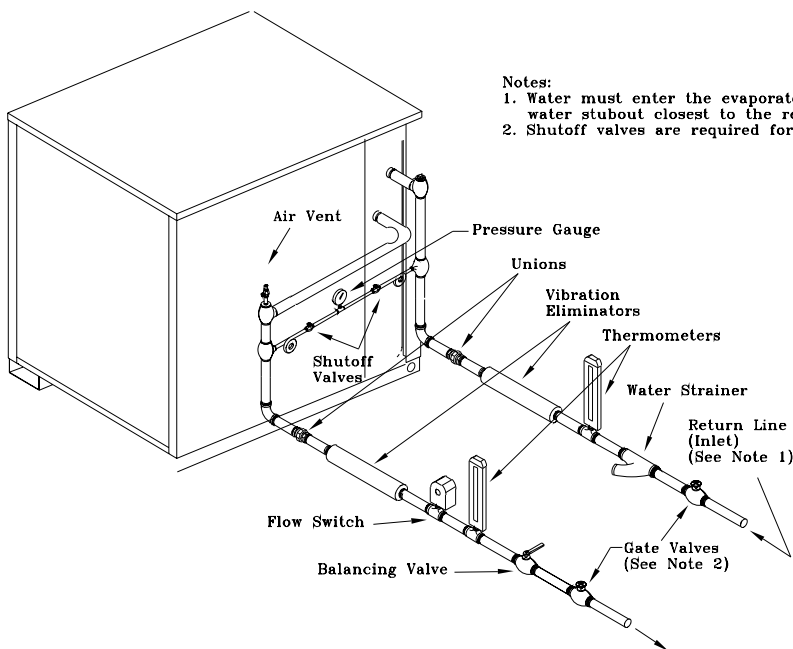

### Piping Components

Figure 4 illustrates typical evaporator piping components. Components and layout will vary slightly depending upon the locations of the connections and water source.

Provide vents at high points in the piping to bleed air from the chilled water system. Install pressure gauge(s) to monitor entering and leaving chilled water pressure.

---

### ▲ CAUTION:

To prevent damage to waterside components, do not allow evaporator pressure to exceed 350 psig (i.e. maximum working pressure).

---

Provide shutoff valves in the water line(s) to the gauge(s) - as shown in Figure 4 - to isolate them from the rest of the system when they are not in use. Use pipe unions to simplify disassembly for system service, and vibration eliminators to prevent vibration transmission through the water lines.

Install thermometers in the lines to monitor evaporator entering and leaving water temperatures, and a balancing cock in the leaving water line to establish a balanced water flow. Install shutoff valves in both the entering and leaving water lines to isolate the evaporator for service.

To protect components from waterborne debris, install a pipe strainer in the evaporator supply line.

## Evaporator Drain

The 1/2 inch NPT drain plug is located in the leaving water tee near the bottom of the evaporator of the CGA100 / CGA 180. The CGA100 / CGA 120 features a drain valve rather than a plug. See "Extended Unit Shutdown/Winterization" for draining instructions.

---

**Note: If the system has been drained for shutdown, do NOT energize heat tapes.**

---

## Evaporator Flow Switch

Use of a flow sensing device such as a flow switch is required to prevent or stop compressor operation if the evaporator water flow drops off dramatically. Refer to unit schematic and to the flow switch installation instructions when installing this device.

---

**Note: Provide shutoff valves in the evaporator inlet and outlet piping to facilitate water temperature sensor removal.**

---

---

**Important!**  
**When installing water pipes, be certain to route them away from the compressor access panels to allow for compressor servicing or replacement.**

---

## Freeze Protection

### General

Use the procedure described below to ensure that the chilled water system is adequately protected from freeze-up in those applications where the unit remains operational at subfreezing ambient temperatures.

1. Install chilled water piping heat tape along with a fused disconnect switch, refer to the instructions outlined under "Heat Tape Installation". Ensure that all exposed piping is adequately protected.

---

**Note: Heat tape is factory-installed on the unit evaporator. This heat tape will protect the evaporator from freeze-up at ambient temperatures down to -20 deg F when used in conjunction with properly applied heat tape on the field-installed water lines. Heat tape power draw is 42 watts on CGA100 / CGA 120 units and 84 watts on CGA150 / CGA 180 units.**

---

2. Freeze-proof the chilled water system by adding a non-freezing, low-temperature, heat-transfer fluid to the chilled water system. Provide protection against ice formation at 10 deg F below the lowest expected ambient temperature.

---

**Note: Use of an ethylene glycol-type antifreeze reduces unit cooling capacity; this condition must be accounted for during total system design. Refer to "Ethylene Glycol Adjustment Factor".**

---

### Heat Tape Installation

Install heat tape on all water piping that may be exposed to freezing temperatures. Be sure to use heat tape that is recommended for low-temperature applications; it should be

# Installation

rated at 110/120 volts, thermostatically-controlled, and dissipate 6 to 7 watts per linear foot.

Heat tape selection should be based on the lowest expected ambient temperature-including any wind chill factor. For those tapes not automatically (i.e., thermostatically) controlled, be sure to install an accessory thermostat.

Refer to Tables 2 and 3 for typical heat type characteristics.

To install the heat tape properly, follow the instructions provided by the heat tape manufacturer. If none are provided, use the recommendations outlined below:

1. Wrap the heat tape around the pipe - or apply it straight along the pipe - as necessary to provide the required protection. See Tables 2 and 3.
2. Use friction tape to secure the heat tape to the water pipe.
3. Place the thermostat tightly against - and parallel to the water pipe, then tape it into place at both ends. Be sure to install the thermostat on the most exposed (i.e., coldest) portion of the pipe.
4. Wrap the pipe with weatherproof tape. On vertical pipe runs, start the wrap at the bottom and work up as shown in Figure 5. Be sure to overlap the tape so that it will shed moisture.

---

**Note: If additional protection is required, insulate the pipe with fiberglass wrap before installing the outer wrap.**

---

## CAUTION:

**To prevent excessive heat generation, resulting in electrical failure of the tape, frozen pipes, and unit damage, do not install fiberglass insulation under the outer wrap when using non-thermostatically-controlled heat tape.**

If freezing is a potential problem, all exposed piping, pumps and other components must be similarly protected with heat tape and insulation.

**Figure 5**  
**Typical Insulated Heat Tape Installation (Spiralled Application)**

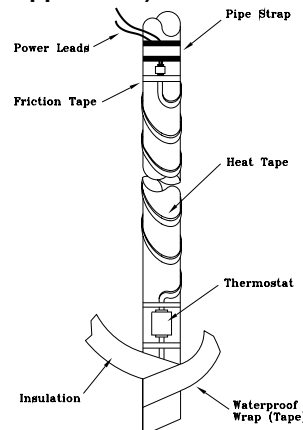

# Installation

**Table 2**  
**Heat Tape Selection Table for Proper Pipe Protection with Fiberglass and Outer Wrap**  
**(Tape Installed Straight Along Pipe)\***

Method Of Wrapping	Nominal Copper Pipe Size									
	3/8"	1/2"	3/4"	1"	1-1/4"	1-1/2"	2"	3"	4"	6"
Tape Required per Foot of Pipe	1 Ft.	1 Ft.	1 Ft.	1 Ft.	1 Ft.	1 Ft.	1 Ft.	1 Ft.	1 Ft.	1 Ft.
Protection Down to (F)	-60	-41	-30	-19	-12	-6	0	9	14	26

\* All values calculated at 0 MPH wind, metallic pipe. Fiberglass wrap should not be used with non-automatic models, unless used in conjunction with properly installed thermostat.

**Table 3**  
**Heat Tape Selection Table for Proper Pipe Protection with Fiberglass and Outer Wrap**  
**(Tape Installed Spiralled around Pipe 3 Turns per Foot) \***

Method Of Wrapping	Nominal Copper Pipe Size									
	3/8"	1/2"	3/4"	1"	1-1/4"	1-1/2"	2"	3"	4"	6"
Tape Required per Foot of Pipe	NR	NR	1' 6"	1' 8"	1' 10"	2' 1"	2' 4"	2' 11"	3' 11"	5' 0"
Protection Down to (F)	NR	NR	-60	-55	-51	-50	-45	-41	-37	-35

\* All values calculated at 0 MPH wind, metallic pipe. Fiberglass wrap should not be used with non-automatic models, unless used in conjunction with properly installed thermostat.

NR = Not Recommended

**Table 4**  
**Electrical Data for CGA 10 and 15 Ton Units**

Model Number	Basic Unit Characteristics				Compressor Motor		Outdoor Fan Motor			
	Unit Electrical Characteristics	Allowable Voltage Range	Minimum Circuit Ampacity	Maximum Fuse Size	Qty.	Amps		Qty.	HP	Amps FLA
						RLA	LRA			
CGA120B1	208-230/60/1	187-254	74.0	100	2	30	169.0	1	1	6.0
CGA120B3	208-230/60/3	187-254	38.4	50	2	14.4	128.0	1	1	6.0
CGA120B4	460/60/3	414-506	24.1	30	2	9.5	63.0	1	1	2.7
CGA120BW	575/60/3	518-632	18.4	25	2	7.3	49.0	1	1	2.0
CGA100BD	380-415/50/3	342-456	24.1	30	2	9.5	63.0	1	1	2.7
CGA180B3	208-230/60/3	187-254	68.1	90	2	27.5	208.0	2	.5	3.1
CGA180B4	460/60/3	414-506	32.7	45	2	13.1	99.5	2	.5	1.6
CGA180BW	575/60/3	518-632	25.1	30	2	10.1	68.0	2	.5	1.2
CGA150BD	380-415/50/3	342-456	32.7	45	2	13.1	100.0	2	.5	1.6

Notes:

1. Minimum circuit ampacity is 125% of the largest compressor RLA (see Table 4) plus 100% for the second compressor RLA plus the sum of the condenser fan FLAs per NEC 440-33.
2. Maximum fuse size is 225% of the largest compressor RLA plus 100% of the second compressor RLA plus the sum of the condenser fan FLAs, per NEC 440-22.
3. Recommended dual-element fuse size is 150% of the largest compressor RLA plus 100% of the second compressor RLA plus the sum of the condenser fan FLAs.
4. Rated load amps (RLA) rated in accordance with UL Standard 465.
5. Use copper conductors only.
6. Local codes may take precedence.

# Installation

**Table 5**  
**Minimum Starting Ambient Temperature for CGA Units**

	Standard Units		Low Ambient Units	
	with HGBP	No HGBP	with HGBP	No HGBP
CGA100B	60	50	15	0
CGA120B	60	50	15	0
CGA150B	60	50	15	0
CGA180B	60	50	15	0

Note:

1. Minimum starting ambients in degrees F, based on unit at minimum step of unloading and 5 mph wind across condenser.

**Table 6**  
**Control Settings and Time Delays for CGA Units**

Control Description	Electrical Designation	Contacts Open	Contacts Close (Reset)
High Pressure Cutout	HPC01, HPC02	400 ± 10 psig	250 ± 15 psig
Low Pressure Cutout	LPC01, LPC02		
Std. Units		38.5 ± 1 psig	44.5 ± 2 psig
*LLST Units		See Table 6A	See Table 6A
Low Temperature Cutout	LTC		
Std. Units		36 ± 3 psig	Manual Reset
*LLST Units		See Table 6A	See Table 6A
Control Description	Electrical Designation	Contacts Status	Time Delay Duration
Anti-Short Cycle Timer	ASCT1, ASCT2	Normally-Open timed to close	3 Minutes
Delay Between Compressors	DBC	Normally-Open timed to close	30 Seconds
Low Ambient Start Timer	LAST1, LAST2	Normally-Closed timed to open	4 Minutes
Hot Gas Bypass Timer	HGBT	Normally-Closed timed to open	30 Minutes

\* LLST = Low Leaving Solution Temp Units.

**Table 6A**  
**Control Settings for Low Leaving Solution Temperatures**

Minimum LWT (deg F)	Ethylene-Glycol Concentration (%)	Solution Freeze Temp (F)	Low Temperature Cutout (deg F)		Low Pressure Cutout (psig)	
			Open	Close	Open	Close (Reset)
35	8	27	31	Manual Reset	33.8	38.5
30	13	22	27	Manual Reset	29.1	33.8
25	19	17	22	Manual Reset	24.9	29.1
20	24	11	16	Manual Reset	20.1	24.0
10	32	2	7	Manual Reset	13.9	17.2

Note: The settings are field adjusted to match the required leaving solution temperature.

## Electrical Wiring

All wiring must comply with National Electrical Code (NEC) and state and local requirements. Outside the United States, the national and/or local electrical requirements of other countries shall apply. The installer must provide properly sized system interconnecting and power supply wiring with appropriate fused disconnect switches. Type and locations of disconnects must comply with all applicable codes.

Figures 2 and 3 show the locations of the unit electrical access openings. Table 4 provides minimum circuit ampacities, recommended fuse sizes, and motor electrical data.

### CGA Unit Power Supply

Refer to the unit wiring schematic pasted to the control panel cover. The installer must provide a power supply of proper voltage and a fused disconnect switch to the CGA unit.

Run properly sized power wiring through the electrical access opening on the front of the CGA unit, (see Figures 2 and 3), and connect it to the High Voltage Terminal Block (HTB) in the unit control panel. Provide proper equipment grounds for the ground connections in the unit control panel and at the fused disconnect switch.

---

**Important! All 208-230 volt units are factory-wired for 230 volt applications. If the power supply voltage is less than 215 VAC, refer to the unit electrical schematic pasted to the inside of the control panel cover to convert the transformer to 208 volt.**

---

### Heat Tape Power Supply (For Unit Evaporator)

The evaporator is insulated from ambient air, and protected from freezing by thermostatically controlled heat tape(s). Whenever the thermostat senses 38 F ( $\pm$  3 F), it closes, energizing the heat tape(s).

Provide an independent power source with a fused disconnect switch to the evaporator heater junction box shown in the unit schematic diagram. Power requirement for unit heat tape only is 115 V max fuse size is 7 amps. Customer connections are illustrated in Figures 2 and 3. Electrical wiring between the evaporator heat tape and the junction box is factory installed.

### Heat Tape Power Supply (For Field-Installed Piping)

Provide power supply wiring - along with a properly sized fused disconnect switch - for any electrical heat tape applied to the system water piping.

### Interconnecting System Wiring

---

**⚠ WARNING:  
HAZARDOUS VOLTAGE!**

**DISCONNECT ALL ELECTRIC POWER INCLUDING REMOTE DISCONNECTS BEFORE SERVICING.**

**Failure to disconnect power before servicing can cause severe personal injury or death.**

---

## Installation

---

**⚠ CAUTION:  
USE COPPER CONDUCTORS ONLY!  
UNIT TERMINALS ARE NOT DESIGNED TO ACCEPT OTHER TYPES OF CONDUCTORS.**

**Failure to do so may cause damage to the equipment.**

---

### Chilled Water Pump Motor (CWPM) Power Supply

Refer to the unit wiring schematic pasted to the control panel cover. The installer must provide a power supply of proper voltage and a fused disconnect switch to the chilled water pump motor circuit.

Run properly sized power wiring to the chilled water pump motor and install a fused disconnect switch as required by local codes. Provide proper equipment grounds for the ground connections at the pump motor and at the fused disconnect switch.

Notice that the chilled water pump starter (CWPS) must have two normally - open auxiliary contacts; one of which must be wired in series with upstream of the flow switch.

### Flow Switch Interlock

To avoid possible evaporator freeze-up resulting from restricted water flow, install a flow switch (or other flow sensing device) in the evaporator water line; see "Unit Water Piping". This sensing device must be adjusted to stop compressor operation if water flow to the evaporator drops below 50 percent of the system design full-flow rate.

The installing contractor must provide interconnecting wiring between the unit control panel, the auxiliary contacts of the chiller water pump starter (CWPS), and the flow-sensing device in the evaporator water line. Connect the switch between LTB1-8 and LTB1-9 in the unit control panel.

### Factory Supplied, Field Installed Accessories

The following is a list of factory supplied, field installed accessories that may be purchased with the CGA 10 and 15 Ton units. For proper installation and wiring (if applicable) of each accessory, refer to the installer's guide that ships with each accessory.

1. Integrated Comfort System Interface\*
2. Head Pressure Control(s) (Low Ambient Controls)
3. Power Supply Monitor \*\*
4. Elapsed Time Meter/# of Starts Counter
5. Flow Switch
6. Unit Isolators
7. Coil Guard Kit
8. Pressure Gauges

\* ICS kit and TCM module are both required for Integrated Comfort System Interface. These two items must be ordered separately.

\*\* Not available on Single Phase Units

Complete this checklist as the unit is installed to verify that all recommended procedures are accomplished before the unit is started. **This checklist does not replace the detailed instructions given in the "Installation" section of this manual!** Read the entire section carefully to become familiar with installation procedures before installing the unit.

### Receiving

Verify that unit nameplate data corresponds with ordering information.

Inspect the unit for shipping damages and material shortages; report any damages or shortages found to the carrier.

### Unit Location and Mounting

Inspect unit installation location for adequate ventilation.

Provide drainage facilities for evaporator water.

Remove and discard any shipping materials (e.g., cartons, crates, etc.)

Inspect to determine that service access clearances are adequate.

Install optional unit neoprene-in-shear or spring-flex isolators.

Secure unit to mounting surface.

Level the unit.

### Evaporator Piping

Flush and clean all chilled water piping.

---

## CAUTION:

**If using an acidic commercial flushing solution, construct a temporary bypass around the unit to prevent damage to the evaporator's internal components.**

---

## CAUTION:

**To avoid possible equipment damage, do not use untreated - or improperly treated - system water.**

---

Make evaporator water connections.

Vent chilled water system at high points in the system piping.

Install pressure gauges, thermometers and shutoff valves on water inlet and outlet piping.

Install balancing valve and flow switch on water outlet piping.

# Installation Checklist

---

Apply heat tape and insulation as necessary to protect all exposed field installed piping from freeze-up.

### Electrical Wiring

---

## WARNING:

**HAZARDOUS VOLTAGE!**

**DISCONNECT ALL ELECTRIC POWER INCLUDING REMOTE DISCONNECTS BEFORE SERVICING.**

**Failure to disconnect power before servicing can cause severe personal injury or death.**

---

## CAUTION:

**USE COPPER CONDUCTORS ONLY!**

**UNIT TERMINALS ARE NOT DESIGNED TO ACCEPT OTHER TYPES OF CONDUCTORS.**

**Failure to do so may cause damage to the equipment.**

---

Connect unit power supply wiring (with fused disconnect) to appropriate terminals on terminal block (HTB) in power section of unit control panel.

208-230 Volt Units Only. If supply power is 208 V, modify transformer wiring as described on unit wiring diagrams.

Connect chilled water pump power supply wiring (with fused disconnect) to the proper terminals of the chilled water pump.

Properly ground the CGA unit, the chilled water pump motor, all disconnects, and other devices which require grounds.

Install wiring between field-supplied, fused disconnect switch and unit evaporator heat tape junction box.

Connect power supply wiring, along with a fused disconnect switch, to any auxiliary heat tape installed on the system water piping.

Install wiring to connect chilled water pump switch (CWPSW) to chilled water pump starter (CWPS).

Connect auxiliary contacts of chilled water pump starter (CWPS) to flow switch and unit control panel.

Install wiring to connect flow switch to unit control panel.

### Field-Install Accessories

Install and wire any accessories per the appropriate installer's guide (see "Electrical Wiring: Factory Supplied, Field Installed Accessories").

## Pre-Start Checklist

Once the unit is installed, complete each step in the checklist that follows, check off each step as it is completed. When all are accomplished, the unit is ready for operation.

---

### **WARNING:** **HAZARDOUS VOLTAGE!**

**DISCONNECT ALL ELECTRIC POWER INCLUDING REMOTE DISCONNECTS BEFORE SERVICING.**

**Failure to disconnect power before servicing can cause severe personal injury or death.**

---

Inspect all wiring connections; electrical connections should be clean and tight.

---

### **WARNING:** **HAZARDOUS VOLTAGE!**

**DISCONNECT ALL ELECTRIC POWER INCLUDING REMOTE DISCONNECTS BEFORE SERVICING. USE EXTREME CARE WHEN ELECTRICALLY TROUBLESHOOTING COMPRESSORS. IF ELECTRICAL POWER IS APPLIED TO A DAMAGED FUSITE TERMINAL, A FIRE OR EXPLOSION COULD OCCUR.**

**Failure to disconnect power before servicing can cause severe personal injury or death.**

---

---

### **CAUTION:**

**CHECK TIGHTNESS OF ALL CONNECTIONS IN THE COMPRESSOR POWER CIRCUIT (DISCONNECTS, TERMINAL BLOCK, CONTACTORS, COMPRESSOR JUNCTION BOX TERMINALS, ETC.) TO PREVENT OVERHEATING AT CONNECTIONS AND UNDER VOLTAGE CONDITIONS AT THE COMPRESSOR MOTOR.**

Check power supply voltage to the unit at the main power fused disconnect switch; the voltage reading obtained must be within the voltage utilization range shown in Table 4. Also, voltage imbalance must not exceed 2 percent. (Refer to "Unit Voltage and Amperage Checks").

Check the condenser fan assemblies, the fan blades should rotate freely in the fan orifice, and be securely attached to the fan shaft.

Remove control circuit Fuse (FU) from the main unit control panel; then energize the compressor crankcase heaters by closing the unit's fused disconnect switch. The crankcase heaters should operate at least 8 hours before the compressors are allowed to start.

---

**NOTE: To prevent compressor operation during this 8-hour interval, control circuit Fuse (FU) must be removed from the unit control panel.**

---

## Pre-Start Procedures

---

---

### **CAUTION:**

**COMPRESSOR CRANKCASE HEATERS MUST BE ENERGIZED AT LEAST 8 HOURS BEFORE START-UP TO PREVENT COMPRESSOR OR MECHANICAL DAMAGE.**

**Failure to do so may cause damage to the equipment.**

---

Fill the chilled water (evaporator) circuit, leaving the system air vents open. Close vents after filling.

---

### **CAUTION:**

**To avoid possible equipment damage, do not use untreated - or improperly treated - system water.**

---

Close the chilled water circuit fused disconnect switch, and start the chilled water pump motor (CWPM). With water circulating through the chilled water system, inspect all piping connections for leaks and make any necessary repairs.

Adjust the water flow rate through the chilled water circuit, and check the water pressure drop through the evaporator. Refer to "Water System".

Open the CGA unit disconnect switch; then reinstall the control circuit Fuse (FU) in the unit control panel (i.e., provided the compressor crankcase heaters have been energized at least 8 hours), and re-close the disconnect switch. Adjust the flow switch (installed on the evaporator outlet piping) to provide proper operation.

---

**NOTE: With the water pump operating, throttle the water flow to approximately 50 percent of the full flow rate. Following the manufacturer's instructions, adjust the flow switch contacts to open at this point. Use an ohmmeter to verify opening and closure of the switch contacts.**

---

Stop the chilled water pump.

Open all fused disconnect switches.

### Unit Voltage and Amperage Checks

---

### **WARNING:** **HAZARDOUS VOLTAGE!**

**DISCONNECT ALL ELECTRIC POWER INCLUDING REMOTE DISCONNECTS BEFORE SERVICING.**

**Failure to disconnect power before servicing can cause severe personal injury or death.**

---

Electrical power to the unit must meet stringent requirements for the unit to operate properly. Total voltage supply and voltage imbalance between phases should be within the following tolerances.

# Pre-Start Procedures

## Voltage Supply - 3-Phase Units Only

Measure each leg of supply voltage at all line voltage disconnect switches. Readings must fall within the voltage utilization range shown on the unit nameplate. If voltage on any leg does not fall within tolerance, notify the power company to correct this situation before operating the unit. Inadequate voltage to the unit will cause control components to malfunction and shorten the life of electrical components and compressor motors.

### Voltage Imbalance

Excessive voltage imbalance between phases in a three-phase system will cause motors to overheat and eventually fail. Maximum allowable imbalance is 2 percent. Voltage imbalance is defined as follows:

$$\% \text{ Voltage Imbalance} = \frac{100 \times |V_A - V_D|}{V_A}$$

$$\text{where } V_A = \frac{V_1 + V_2 + V_3}{3} \quad (\text{Avg. Voltage})$$

$V_1 \ V_2 \ V_3 =$  Line Voltages

$V_D =$  Line voltage that deviates farthest from  $V_A$

### Example:

If the three voltages measured at the line voltage fused disconnect are 221 volts, 230 volts and 227 volts, the average ( $V_A$ ) would be:

$$\frac{221 + 230 + 227}{3} = 226 \text{ volts}$$

The percentage of imbalance is then:

$$\frac{100 \times |226 - 221|}{226} = 2.2 \%$$

The 2.2 percent imbalance that exists in the example above exceeds maximum allowable imbalance by 0.2 percent. This much imbalance between phases can equal as much as 20 percent current imbalance with a resulting increase in winding temperature that will decrease compressor motor life.

**Table 7**  
**CGA Evaporator Data**

Unit	Water * Volume gal.	Minimum Flow Rate gpm	Maximum Flow Rate gpm
CGA100B	1.4	12	36
CGA120B	1.4	12	36
CGA150B	1.5	18	54
CGA180B	1.5	18	54

\* Includes water tubing provided by the factory.

Feet of water = psi x 2.307

## Water System: Water Flow Rates

Establish a balanced water flow through the evaporator. Flow rates should fall between the minimum and maximum values indicated in Table 7. Evaporator water flow rates below the minimum acceptable values will result in a stratified flow; this reduces heat transfer and causes either loss of expansion valve control or repeated nuisance low pressure cutouts. Conversely, excessively high rates may cause erosion of components in the evaporator.

### Pressure Drop Measurement

Measure the water pressure drop through the evaporator at the pressure gauge(s) on the system water piping. Pressure drop readings at the gauges should approximate those indicated by the pressure drop chart in Figure 6.

**NOTE: The pressure drop curves shown in Figure 6 are calculated at the unit water inlet and outlets. Be sure to account for any piping or fittings that may create an additional pressure drop between the unit and the pressure gauge locations.**

**Figure 6**  
**CGA 10 and 15 Ton Evaporator Water Pressure Drop (English)**

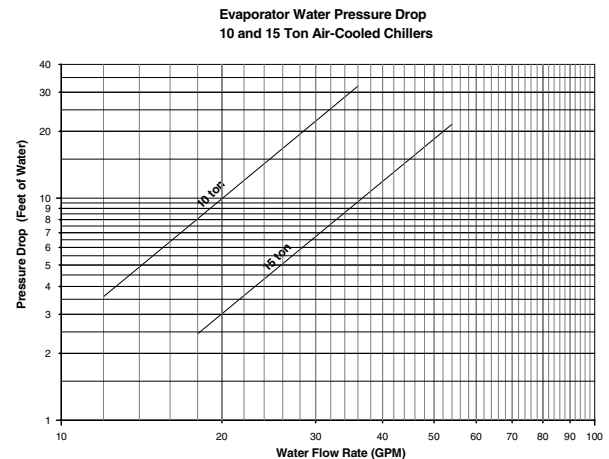

# Pre-Start Procedures

**Table 8**  
Normal Operating Pressures (Approximate)

Ambient (F)	CGA100 / CGA120		CGA150 / CGA180	
	Suction Pressure (psig)	Discharge Pressure (psig)	Suction Pressure (psig)	Discharge Pressure (psig)
45	58	128	51	139
60	59	163	57	174
75	60	204	59	214
85	60	234	60	244
95	61	257	61	271
105	63	297	62	315
115	65	355	63	349

Notes:

1. Based on steady stat conditions with 54°F entering water temp (EWT) and 44°F leaving water temp (LWT).
2. An increase of 5°F in LWT while keeping the 10°F temperature drop will result in an increase of approximately 6 psi in suction pressure and an increase of approximately 10 psi in discharge pressure when compared to the 54° EWT. 44° LWT given in Table 8.
3. Pressures at low ambients will not match this table if a head pressure control is installed and operating.

### Ethylene Glycol Adjustment Factor

The addition of ethylene glycol to the chilled water system reduces unit capacity. To determine pressure drop of a glycol solution, obtain the pressure drop adjustment factor from the chart in Figure 7 and multiply times the pressure drop of water without glycol, i.e.;

$$\text{Glycol } \Delta P = \text{H}_2\text{O } \Delta P \times \text{Adj. Factor}$$

**Figure 7**  
Performance Adjustments and Solution Freezing Points  
(Ethylene Glycol in Evaporator)

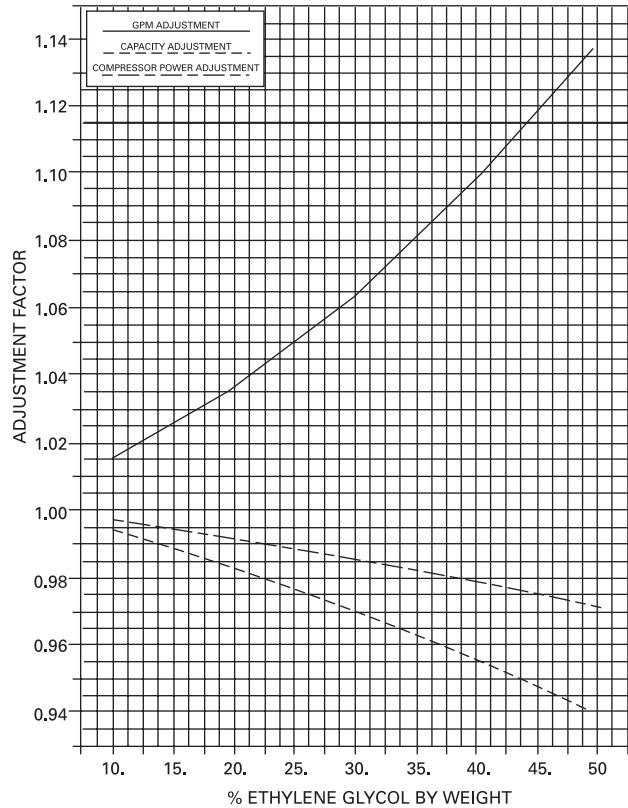

## Start-Up Procedure

To properly start the unit, execute each step of the checklist that follows in the sequence indicated; check off each step as it is completed. Do not start the unit until the "Pre-Start Procedures" are complete. (Refer to Figure 9 for the unit operating controls locations.)

[ ] Open the unit disconnect switch; then remove control circuit Fuse (FU) from the unit control panel. (This will prevent the compressors from energizing when the disconnect switch is closed.)

---

### **WARNING:** HAZARDOUS VOLTAGE!

**DISCONNECT ALL ELECTRIC POWER INCLUDING REMOTE DISCONNECTS BEFORE SERVICING.**

**Failure to disconnect power before servicing can cause severe personal injury or death.**

---

[ ] Close the fused disconnect switch for the evaporator chilled water pump. Start the pump.

[ ] Close the fused disconnect switch for the CGA unit.

---

**NOTE: The unit's compressor crankcase heaters will energize when the disconnect switch is closed; these crankcase heaters must operate at least 8 hours before the compressors are allowed to start.**

---

---

### **CAUTION:**

**COMPRESSOR CRANKCASE HEATERS MUST BE ENERGIZED AT LEAST 8 HOURS BEFORE START-UP TO PREVENT COMPRESSOR OR MECHANICAL DAMAGE.**

**Failure to do so may cause damage to the equipment.**

---

[ ] After the compressor crankcase heaters have operated a minimum of 8 hours, open the unit disconnect switch, re-install control circuit Fuse (FU) in the unit control panel, and re-close the disconnect switch.

[ ] Energize the evaporator heaters by closing the fused disconnect switch provided by the installer. (The factory-installed evaporator heat tape should be energized whenever there is water in the unit evaporator.)

[ ] Reset any control that requires a manual reset.

[ ] If the unit is a low leaving solution temperature model, adjust the low pressure cutout setting and the low temperature cutout setting according to Table 6A. Disconnect power before adjusting.

[ ] Set the water temperature thermostat (WTT) as described on page 23.

## Start-Up

---

### Checking Operating Conditions

Once the unit has operated for at least 30 minutes and the system has stabilized, complete the following checklist to ensure proper unit operation.

[ ] Recheck evaporator water flow and pressure drop. These readings should be stable at proper levels. Refer to "Water System". If pressure differential drops off, clean all evaporator water supply strainers.

[ ] Measure unit suction and discharge pressures by installing pressure gauges on the discharge and suction line access ports. Refer to Table 8 for approximate normal operating pressures.

---

**NOTE: Many applications variables exist which can affect operating pressures; these include ambient dry bulb temperature, as well as the installation of such options as head pressure controls or hot gas bypass. Since these variables can give misleading results, do not use operating pressures as the sole check of system operation.**

---

[ ] Check compressor amp draw.

[ ] Check electrical power supply.

[ ] Check the liquid line sight glasses/moisture indicators for the presence of moisture.

---

**NOTE: Bubbles in the liquid line may indicate either a low refrigerant charge, or excessive pressure drop in the liquid line. Such a restriction can often be identified by a noticeable difference in line temperature on either side of the restricted area. (Frost often forms on the outside of the liquid line at the point of restriction, as well.) Bubbles are not necessarily a symptom of improper system operation.**

---

---

### **CAUTION:**

**A CLEAR SIGHT GLASS DOES NOT NECESSARILY MEAN THAT THE SYSTEM IS SUFFICIENTLY CHARGED; BE SURE TO CONSIDER SYSTEM SUPERHEAT, SUBCOOLING, AND UNIT OPERATING PRESSURES AND AMBIENT TEMPERATURES.**

**Failure to do so may cause damage to the equipment.**

---

Proper unit refrigerant charge - per circuit - is indicated on the unit nameplate and also under "Refrigerant Charge Information" in this manual.

[ ] Measure system superheat.

## Start-Up

---

Normal system superheat is 12 to 15 deg F for each circuit at ARI conditions (54° entering water, 44° leaving water, and 95° ambient temperature). If the superheat measured for either circuit does not fall within this range, alter the setting of the superheat adjustment on the thermal expansion valve to obtain the desired reading. Allow 15 to 30 minutes between adjustments for the expansion valve to stabilize at each new setting.

[ ] Measure system subcooling.

Normal subcooling for each circuit is 12 to 22 deg F at ARI conditions (54° entering water, 44° leaving water, and 95° ambient temperature). If subcooling for either circuit is not in this range, check superheat for the circuit and adjust, if required. If superheat is normal but subcooling is not, contact a qualified service technician.

[ ] If operating pressure, sight glass, superheat and subcooling readings indicate refrigerant shortage, find and repair leaks and, gas-charge refrigerant into each circuit. Refrigerant shortage is indicated if operating pressures are low and subcooling is also low.

### Refrigerant Charge Information

The CGA100 / CGA120B units have 8 lbs. 4 oz. of refrigerant **per circuit**, and the CGA150 / CGA 180B units have 11 lbs. 8 oz. of refrigerant **per circuit**.

---

### CAUTION:

**IF SUCTION AND DISCHARGE PRESSURES ARE LOW, BUT SUBCOOLING IS NORMAL, NO REFRIGERANT SHORTAGE EXISTS. ADDING REFRIGERANT WILL RESULT IN OVERCHARGING.**

**Failure to do so may cause damage to the equipment.**

---

Add refrigerant vapor with the unit running by charging through the access port on the suction line until operating pressures are normal.

---

### CAUTION:

**TO PREVENT COMPRESSOR DAMAGE, DO NOT ALLOW REFRIGERANT TO ENTER THE SUCTION LINE. LIQUID LINE CHARGE AT THE LIQUID LINE ONLY.**

**Failure to do so may cause damage to the equipment.**

---

[ ] If operating pressures indicate an overcharge, slowly (to minimize oil loss) recover refrigerant at the liquid line service valve.

---

#### **IMPORTANT NOTE:**

**Do NOT release refrigerant into the atmosphere! Refer to general service bulletin MSCU-SB-1 (latest edition).**

---

---

### CAUTION:

**TO PREVENT INJURY DUE TO FROSTBITE, AVOID SKIN CONTACT WITH REFRIGERANT.**

---

[ ] If the unit is equipped with hot gas bypass, check regulating and solenoid valves for proper operation.

[ ] Be sure that all remote sensing bulbs are properly installed in bulb wells with heat transfer compound. Remote bulb capillary tubes must be secured (i.e., protected from vibration and abrasion) and undamaged.

[ ] Inspect the unit. Remove any debris, tools and hardware. Secure all exterior panels, including the control and compressor access panels. Replace and tighten all retaining screws.

### Temporary Unit Shutdown and Restart

To shut down the unit for a short time:

1. Open the unit disconnect switch; then remove control circuit Fuse (FU) from the main unit control panel. Once the control circuit Fuse (FU) is removed, reclose the unit disconnect switch. This will ensure that the compressor crankcase heater remain energized.

---

### WARNING:

**HAZARDOUS VOLTAGE!**

**DISCONNECT ALL ELECTRIC POWER INCLUDING REMOTE DISCONNECTS BEFORE SERVICING.**

**Failure to disconnect power before servicing can cause severe personal injury or death.**

---

2. Stop operation of the chilled water pump.

To restart the unit after a temporary shutdown:

1. Restart the chilled water pump.

2. Open the unit disconnect switch; then reinstall the control circuit Fuse (FU) in the main unit control panel. Once the Fuse (FU) is installed, close the unit disconnect switch.

---

### WARNING:

**HAZARDOUS VOLTAGE!**

**DISCONNECT ALL ELECTRIC POWER INCLUDING REMOTE DISCONNECTS BEFORE SERVICING. OPEN THE UNIT DISCONNECT SWITCH BEFORE INSTALLING CONTROL CIRCUIT FUSE (FU) IN THE CONTROL PANEL.**

**Failure to disconnect power before servicing can cause severe personal injury or death.**

---

The unit will now operate normally provided that: (1) the water temperature thermostat (WTT) is calling for cooling, and (2) all system operating interlocks and safety circuits are satisfied.

# Start-Up

## Extended Unit Shutdown/Winterization

If the system is taken out of operation for long periods of time for any reason (e.g., seasonal shutdown), use this procedure to prepare the system for shutdown;

1. Check the refrigerant piping for leaks, fixing any that exist.
2. Service the chilled water pump and any air handling equipment according to the manufacturer's recommendations.
3. Open both electrical disconnect switches for the unit and chilled water pump; lock both disconnects in the open position.

---

### CAUTION:

**LOCK BOTH UNIT AND CHILLED WATER PUMP DISCONNECTS IN THE OPEN POSITION TO PREVENT COMPRESSOR OR PUMP DAMAGE DUE TO ACCIDENTAL START-UP WHILE THE SYSTEM IS IN "SHUTDOWN" CONDITION.**

---

Winterization: Close all evaporator water supply valves and drain the evaporator by removing the drain plug and opening the vent on the entering water line just outside the unit. Reinstall the drain plug. Since the evaporator does not drain completely, add one quart of ethylene glycol antifreeze to the remaining water through the vent or evaporator drain hole, to keep the water from freezing. Or refer to Table 7 and fill the evaporator with antifreeze. Protect the system to 10°F below the expected ambient temperature and energize the evaporator heat tape(s) by closing the heat tape fused disconnect switch provided by the installer.

---

### CAUTION:

**TO PREVENT FREEZE DAMAGE TO THE EVAPORATOR INTERNAL COMPONENTS, PROTECT WITH ADEQUATE STRENGTH ANTIFREEZE, AND BE CERTAIN TO ENERGIZE THE EVAPORATOR HEAT TAPES.**

---

**NOTE: If the system has been drained for shutdown, do NOT energize the heat tape(s).**

---

## System Restart After Extended Shutdown

Use this procedure to prepare the system for restart after an extended shutdown:

1. Remove winterization antifreeze as it can reduce system capacity.
2. Verify that both the unit and the chilled water pump disconnect switches are open; then remove control circuit Fuse (FU) from the unit control panel.
3. Close the unit disconnect switch to energize the compressor crankcase heaters.

---

**NOTE: The unit's compressor crankcase heaters will energize when the disconnect switch is closed; these crankcase heaters must operate at least 8 hours before the compressors are allowed to start.**

---

---

### CAUTION:

**COMPRESSOR CRANKCASE HEATERS MUST BE ENERGIZED AT LEAST 8 HOURS BEFORE START-UP TO PREVENT COMPRESSOR OR MECHANICAL DAMAGE.**

**Failure to do so may cause damage to the equipment.**

---

4. Fill the chilled water (i.e., evaporator) circuit; evaporator shortage capacities are indicated in Table 7 (see "Water System"). Be sure to vent the system while filling it, and close the vent when the system is full.

---

### CAUTION:

**To avoid possible equipment damage, do not use untreated - or improperly treated - system water.**

---

5. Close the chilled water circuit disconnect switch, and start the chilled water pump motor. With water circulating through the chilled water system, inspect all piping connections for leaks and make any necessary repairs.
6. Adjust the water flow rate through the chilled water circuit, and check the water pressure drop through the evaporator. Refer to "Water System".
7. Adjust the flow switch (installed on the evaporator outlet piping) to provide proper operation.

---

**NOTE: With the water pump operating, throttle the water flow to approximately 50 percent of the full flow rate. Following the manufacturer's instructions, adjust the flow switch contacts to open at this point. Use an ohmmeter to check for contact opening and closure.**

---

8. Stop the chilled water pump.
9. Open all fused disconnect switches; then reinstall the control circuit Fuse (FU) (removed in Step 1) in the main unit control panel.

The unit is now ready for normal operation; refer to "Start-Up Procedure".

## Low Ambient Operation

### Field Installed Heat Pressure Control Accessory

Standard units will operate in outdoor ambient temperatures down to (50 deg F - CGA100 / CGA120, 50 deg F - CGA150 / CGA180) without HGBP. This accessory will enable units to operate down to 0 deg F without HGBP. See Table 5.

# Start-Up

---

Head pressure control for CGA units is regulated by means of a field installed heat pressure accessory which varies the condenser fan speed in relation to discharge pressure.

When discharge pressure is 270 psig or higher, the condenser fan runs at full speed. At pressures between 270 psig and 180 psig, the fan speed is adjusted (increased or decreased) in direct relation to the pressure, with minimum fan speed (10% of rated motor RPM) occurring when the pressure reaches 180 psig. At pressures below 180 psig, the fan will not run.

When discharge pressure rises to 180 psig, the fan will start and run at the reduced speed. Fan speed will continue to increase as the pressure increases until full speed is reached at 270 psig.

## Freeze Protection

If the unit will remain operational at subfreezing ambient temperatures, follow the recommendations outlined below to ensure adequate protection for the chilled water system.

1. Energize the chilled water piping heat tape at the fused disconnect switch supplied by the installing contractor. Verify that all exposed piping is adequately protected.
2. "Freeze-proof" the chilled water system by adding a non-freezing, low-temperature heat transfer fluid to the chilled water. The solution used must be strong enough to provide sufficient protection to prevent ice formation at 10 F below the lowest expected ambient temperature.

Follow the manufacturer's recommendations for installation and testing procedures for any freeze-proofing fluid used. Refer to Table 7 for evaporator liquid capacities.

---

**NOTE: Use of an ethylene-glycol type fluid will reduce system capacity. This factor must be considered during system design. See Figure 7.**

---

## Electrical Control System

The controls used on CGA 10 and 15 Ton units are classified either as "safety" controls or "operational" controls. Brief descriptions of the specific safety and operating controls used in the CGA control scheme are provided in the following paragraphs.

Refer to the following control descriptions and to Tables 6 and 6A for control settings, and to Figure 9 for control locations.

## Unit Safety Controls:

### Low Pressure Cutout (LPC01, LPC02)

These units are protected by low pressure cutouts that open and stop compressor operation if the operating pressure drops below  $38.5 \pm 1$  psig. The cutout automatically resets when the pressure reaches  $44.5 \pm 2$  psig. The LPCO is a Single Pole Double Throw (SPDT) device and if it opens at a low ambient start-up, it will energize the Outdoor Fan (ODF) relay, stopping the outdoor fan(s) while the compressor remains energized through the Low Ambient Start Timer (LAST).

### Low Leaving Solution Temperature Units

The LPCO open and reset values are to be field adjusted based on the ethylene glycol concentration per the values shown in Table 6A.

### High Pressure Cutout (HPC01, HPC02)

These units have high pressure cutouts that open and stop compressor operation if the discharge pressure reaches  $400 \pm 10$  psig. The cutout automatically resets when pressure drops to  $250 \pm 15$  psig.

### Reset Relays (RR1, RR2)

If the unit is shut down by the low pressure cutout (or high pressure cutout), the reset relay locks out the compressor contactor (CC1, CC2). This prevents the system from recycling until the condition that caused the low (or high) pressure cutout to trip is determined and corrected.

---

## CAUTION:

**TO PREVENT UNIT DAMAGE, DO NOT RESET THE CONTROL CIRCUIT UNTIL THE CAUSE OF THE SAFETY LOCKOUT IS IDENTIFIED AND CORRECTED.**

**Failure to do so may cause damage to the equipment.**

---

To reset RR1 and RR2, open and reclose the unit disconnect switch.

### Low Temperature Cutout (LTC)

The LTC is designed to protect the evaporator from freeze damage in the event of a water temperature thermostat (WTT) malfunction or restricted water flow. The LTC's remote sensing bulb is in the evaporator, where it monitors leaving water temperature. If - during normal unit operation - the leaving chilled water temperature falls to the trip point, the LTC will open to interrupt compressor operation. (Manual reset is required.)

### Low Leaving Solution Temperature Units

The LTC open value is to be field adjusted based on the ethylene glycol concentration per the values shown in Table 6A.

### Motor Overloads

These units have internal compressor and condenser fan motor overloads. These overloads protect the motors from over-current and overheating conditions and automatically reset as soon as they cool sufficiently.

# Start-Up

---

## Unit Operational Controls

### Water Temperature Thermostat (WTT)

System operation for 10 and 15 ton CGA units is governed by a two-stage water temperature thermostat (WTT). The remote sensing bulb of this device is factory-installed in a bulb well located on the evaporator water inlet; here, it monitors the temperature of the water returning to the evaporator. It has a control range of 5° F per stage, a differential of 5.0 deg F between stages and a setpoint range of -30 to + 100 deg F.

For an explanation on determining the WTT's setpoint and a description of the WTT in operation, refer to that section of this manual.

### Low Ambient Start Timer (LAST1, LAST2)

When LAST1 and LAST2 energizes, the low pressure control is bypassed for 4 minutes, this allows time for suction pressure to build sufficiently for the low pressure cutout contacts to close.

---

***NOTE: A low ambient start timer checkout procedure is given in this manual.***

---

### Hot Gas Bypass Timer, Solenoid (HGBT, HGBS)

The hot gas bypass option is factory installed only, and is used in a chilled water system to keep the 1st stage compressor on line and maintain suction pressure during short no-load or light-load conditions. When Water Temperature Thermostat (WTT) 1st stage opens, 24V power is supplied to the Compressor Contactor (CC1) through Hot Gas Bypass Timer (HGBT) pins 1 and 4. Power is also applied from WTT-B to HGBT coil (fixed 30 minute time delay pickup) and to the Hot Gas Bypass Solenoid (HGBS) through HGBT pins 8 and 5. If 1st stage cooling remains satisfied for 30 minutes, HGBT coil will energize and open HGBT pins 1 and 4 shutting down the compressor. If there is a call for cooling during HGBP mode, the unit will return to cooling mode.

The adjustable hot gas bypass valve is factory set to begin opening at 70 psig.

---

***NOTE: Hot gas bypass is available only on the lead compressor circuit.***

---

### Anti-Short Cycle Timers (ASCT1, ASCT2)

An anti-short cycle timer is provided in each compressor control circuit to protect the compressors from starting too frequently. This can occur as a result of poor thermostat control associated with light loads and water loops that are too short. It can also occur because of sudden power outages of short duration. Whenever the contacts of the water temperature thermostat (WTT) open - or when there is a momentary power outage - the anti-short cycle timer will lock out compressor operation for 3 minutes.

### Delay Between Compressors (DBC)

The delay between compressors prevents both compressors from starting at the same time by delaying compressor #2 for 30 seconds.

## Unit Control System

### Sequence of Operation

Refer to the unit wiring schematic pasted to the inside of the control panel cover when reviewing the control sequence described below. Refer to this legend for an explanation of the acronyms used in this sequence.

CWFIR - Chilled Water Flow Interlock Relay  
LPCO - Low Pressure Cutout  
HPCO - High Pressure Cutout  
ASCT - Anti-short Cycle Timer  
CC - Compressor Contactor  
LTC - Low Temperature Cutout  
DBC - Delay Between Compressors  
WTT - Water Temperature Thermostat  
RR - Reset Relay  
CWPS - Chilled Water Pump Starter

### 10 Ton Operation

With the unit fused disconnect switch closed, power is supplied to the crankcase heaters and the 24 V control circuit.

Starting the chilled water pump closes the CWPS Aux contacts and completes the flow switch.

When the entering water temperature (EWT) rises 5° F above the WTT's setpoint, its first stage switch closes, allowing power to pass through CWPS Aux contacts, the flow switch, the LTC, the ASCT1, the RR1 contacts, the LPCO1, and the HPCO1 to energize the CC1 coil. This starts compressor #1 and the outdoor fan.

### Single Phase Units Only

The single phase compressor requires a start capacitor and a run capacitor to operate. When the CC1 coil energizes and its normally-open contacts close, both the compressor start capacitor (CS1) and the compressor run capacitor (CR1) energize. CR1 remains energized as long as CC1 is energized, but CS1 is dropped out of the circuit when compressor start relay (CSR1) energizes and opens its normally-closed contacts.

If the EWT rises 10° F above the WTT's setpoint, its 2nd stage switch closes, allowing power to pass through the DBC switch, the ASCT2, the RR2 contacts, the LPCO2, and the HPCO2 to energize the CC2 coil which starts compressor #2.

### 15 Ton Operation

With the unit fused disconnect switch closed, power is supplied to the crankcase heaters, and the 24V control circuit.

Starting the chilled water pump closes the CWPS Aux contacts and completes the flow switch, allowing power to pass through the LTC to energize the CWFIR.

When the entering water temperature (EWT) rises 5° above the WTT's setpoint, its first stage switch closes, allowing power to pass through the CWFIR contacts, the ASCT1, the RR1 contacts, the LPCO1, and the HPCO1 to energize the CC1 coil. This starts compressor #1 and outdoor fan #1.

# Start-Up

If the EWT rises 10° F above the WTT's setpoint, its 2nd stage switch closes, allowing power to pass through the CWFIR contacts, the DBC switch, the ASCT2, the RR2 contacts, the LPCO2, and the HPCO2 to energize the CC2 coil. This starts compressor #2 and outdoor fan #2.

## Determining the setpoint for the Water Temperature Thermostat (WTT)

1. Find the difference between the chiller's entering water temperature (EWT) and the leaving water temperature (LWT) while both compressors are running.

$$DT = EWT - LWT$$

2. Decide what minimum leaving water temperature (LWTmin) is desired. This is the minimum temperature that the leaving water reaches during normal cycling of the WTT.

### CAUTION:

**TO PREVENT ICE FORMATION IN THE CHILLER, MAKE SURE THAT THE MINIMUM LEAVING WATER TEMPERATURE (LWTmin) IS NOT LOWER THAN 40 DEG F. IF THE MINIMUM LEAVING WATER TEMPERATURE (LWTmin) IS LOWER THAN 40 DEG F, ADD THE APPROPRIATE AMOUNT OF ETHYLENE GLYCOL AND ADJUST THE SAFETY CONTROL SETTINGS AS SHOWN IN TABLE 6.**

**Failure to do so may cause damage to the equipment.**

Leaving an appropriate safety band between LWTmin and the Low Temperature Cut Out setting is important. See Table 6A for guidance.

3. The WTT set point is then determined by the following formula:

$$WTTsetpoint = LWTmin + DT/2$$

**Figure 8**  
WTT Switching Action

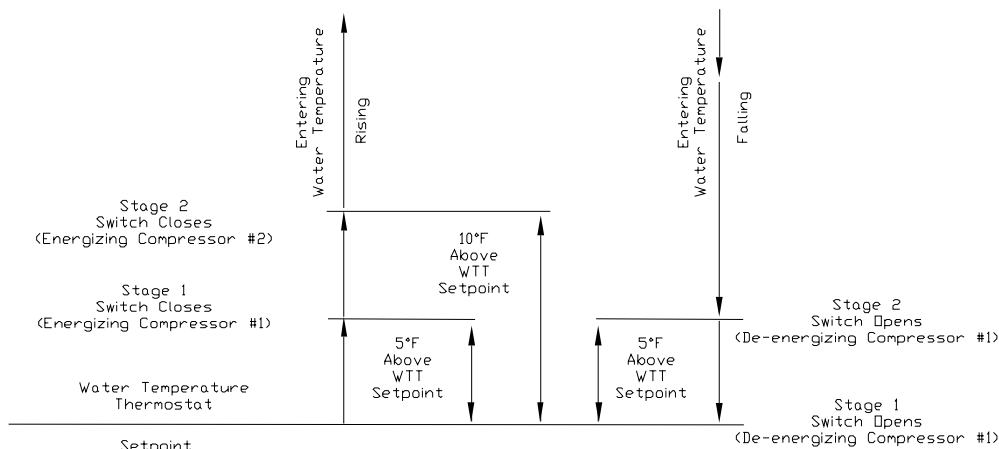

**Note: Actual leaving water temperature will dip lower than the value used in the equation above due to lag in the thermostat's control.**

4. The maximum entering water temperature is computed by:

$$EWTmax = WWTsetpoint + 10$$

**Note: Computing EWTmax is important. If the heat source is not warm enough to allow the EWT to rise to EWTmax, the second stage of cooling may never activate. An example is ice making. If EWTmax is set too high, the ice may be thawed by the solution returning to the chiller during certain portions of the thermostatic cycle, and the second stage of cooling may never be triggered by the thermostat.**

### ADDITIONAL INFORMATION

- A. Average Chiller Leaving Water Temperature (LWTavg) During Two Stage Thermostatic Control as the Load Varies

$$LWTavg = WWTsetpoint - DT/2 + 5$$

- B. The Maximum Leaving Water Temperature During Normal Thermostatic Cycling is computed by:

# Start-Up

---

$$\text{LWTmax} = \text{WTTsetpoint} - \text{DT}/2 + 10$$

-- EXAMPLE --

1. Entering Water Temperature is 55 F based on an actual reading. Leaving Water Temperature is 45.

$$\begin{aligned}\text{DT} &= \text{EWT} - \text{LWT} \\ \text{DT} &= 55 - 45 \\ \text{DT} &= 10 \text{ F}\end{aligned}$$

2. Desired Minimum Leaving Water Temperature is 40 F. This temperature is minimum allowable leaving water temperature without requiring ethylene glycol and special controls settings per Table 6A.

3. New Thermostat Setting:

$$\begin{aligned}\text{WTTsetpoint} &= \text{LWTmin} + \text{DT}/2 \\ \text{WTTsetpoint} &= 40 + 10/2 \\ \text{WTTsetpoint} &= 45 \text{ F}\end{aligned}$$

4. Maximum Entering Water Temperature:

$$\begin{aligned}\text{EWTmax} &= \text{WTTsetpoint} + 10 \\ \text{EWTmax} &= 45 + 10 \\ \text{EWTmax} &= 55 \text{ F}\end{aligned}$$

- A. Average Leaving Water Temperature:

$$\begin{aligned}\text{LWTavg} &= \text{WTTsetpoint} - \text{DT}/2 + 5 \\ \text{LWTavg} &= 45 - 10/2 + 5 \\ \text{LWTavg} &= 45 \text{ F}\end{aligned}$$

- B. Maximum Leaving Water Temperature:

$$\begin{aligned}\text{LWTmax} &= \text{WTTsetpoint} - \text{DT}/2 + 10 \\ \text{LWTmax} &= 45 - 10/2 + 10 \\ \text{LWTmax} &= 50 \text{ F}\end{aligned}$$

## Water Temperature Thermostat Operation

At start up, if the entering water temperature (EWT) is less than 5 deg F above the WTT setpoint, the unit will not run. When the EWT rises to 5 deg F above the WTT setpoint, its first stage switch closes, energizing compressor #1.

If the EWT continues to rise and reaches 10 deg F above the WTT setpoint, its second stage switch closes, energizing compressor #2.

When the cooling demand is met and the EWT drops to 5 deg F above the WTT setpoints, its second stage switch opens, dropping out compressor #2.

If the EWT continues to fall and reaches the WTT setpoint, its first stage switch opens, dropping out compressor #1.

A graphic representation of the above explanation is shown in Figure 8.

**Figure 9**  
Unit Control Panels

CGA100 / CGA120  
CONTROL PANEL

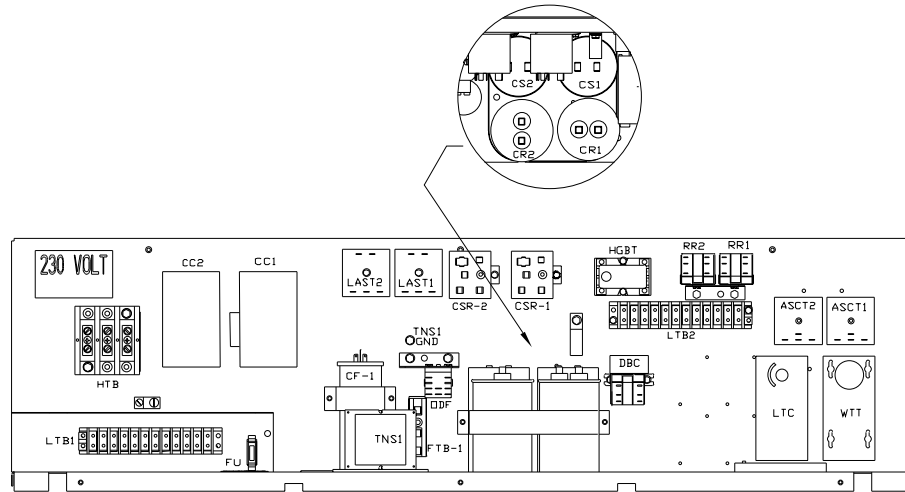

- |              |                                    |              |                              |
|--------------|------------------------------------|--------------|------------------------------|
| ASCT1, ASCT2 | Anti-Short cycle Timers            | HTB          | High Voltage Terminal Block  |
| CC1, CC2     | Compressor Contactors              | LAST1, LAST2 | Low Ambient Start Timers     |
| CF1, CF2     | Outdoor Fan Capacitors             | LTB1, LTB2   | Low Voltage Terminal Blocks  |
| CWFIR        | Chilled Water Flow Interlock Relay | LTC          | Low Temperature Cutout       |
| DBC          | Delay Between Compressors          | ODDF1, ODDF2 | Outdoor Fan Relays           |
| FTB1, FTB2   | Fan Terminal Blocks                | RR1, RR2     | Reset Relays                 |
| FU           | Control Circuit Fuse               | TNS1         | Control Power Transformer    |
| HGBT         | Hot Gas Bypass Timer               | WTT          | Water Temperature Thermostat |
| LPC01, LPC02 | Low Pressure Cutouts               |              |                              |

CGA150 / CGA180  
CONTROL PANEL

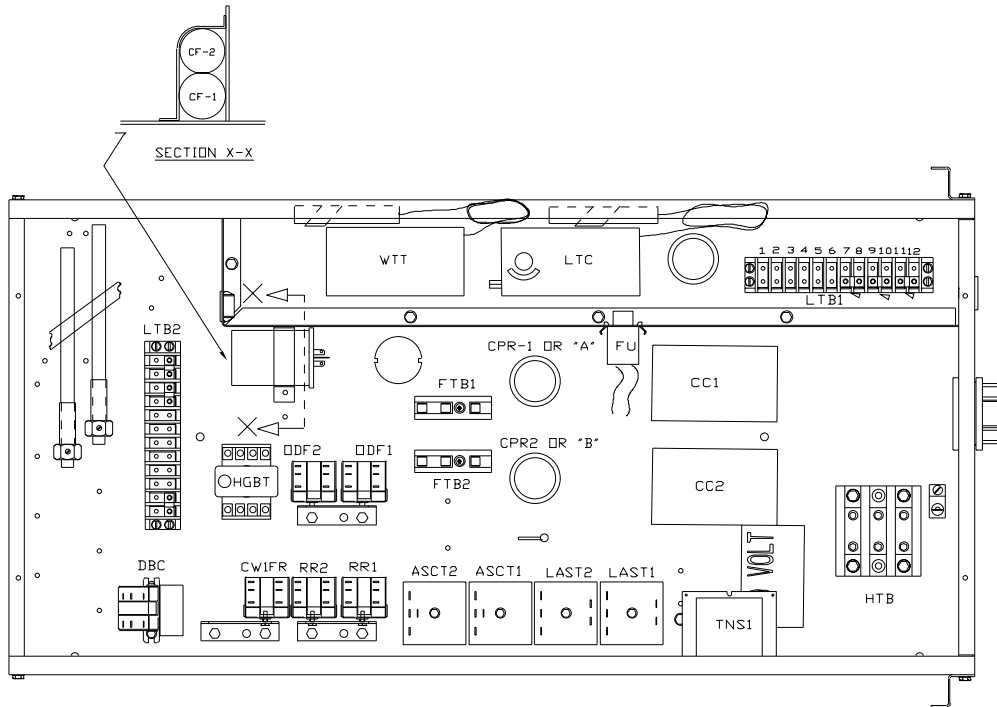
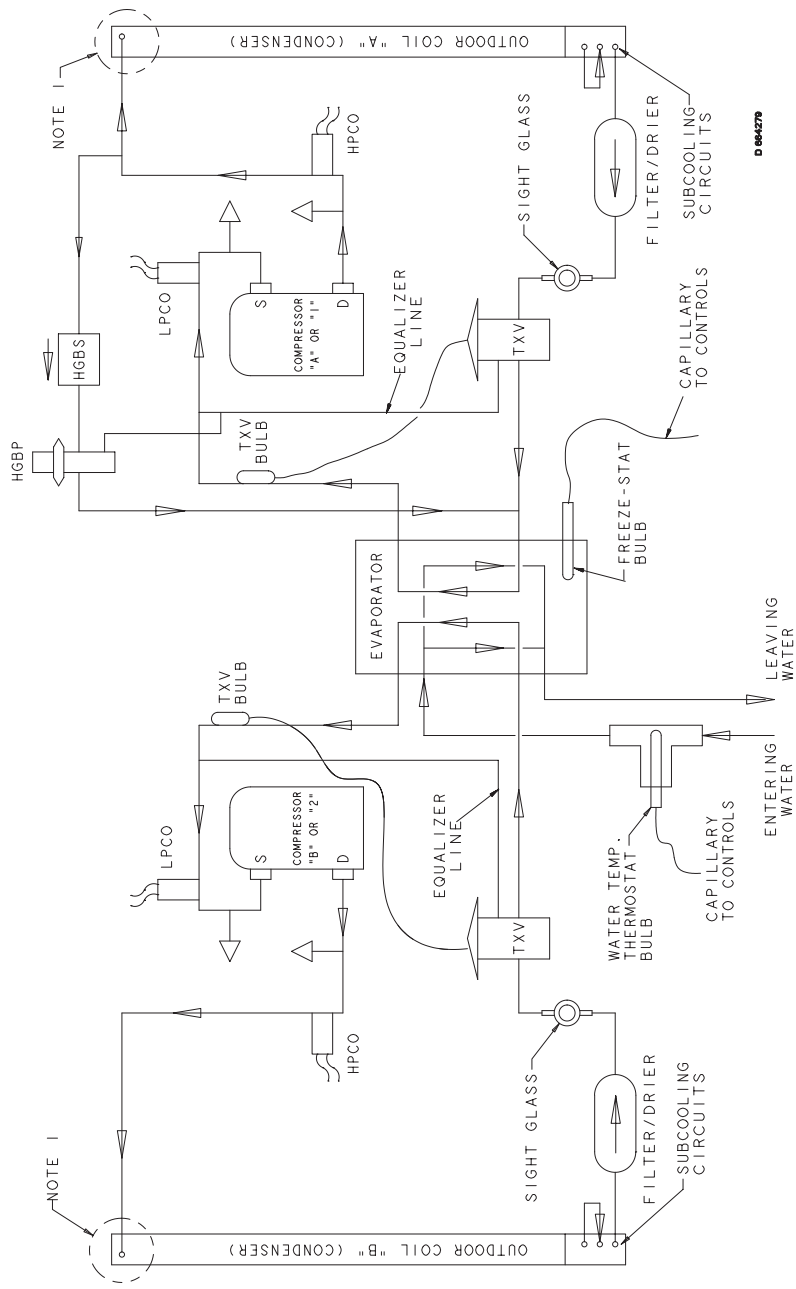

**Figure 10**  
**Unit Refrigeration Schematic for CGA 120B Units**

NOTE 1: CIRCUITS THROUGH THE CONDENSER COILS ARE NOT SHOWN.

**SYMBOL DEFINITION**

- PRESSURE GAGE CONNECTIONS
- LPCO LOW PRESSURE CONTROL CONNECTION
- HPCO HIGH PRESSURE CONTROL CONNECTION
- TXV THERMAL EXPANSION VALVE
- HGBP HOT GAS BYPASS VALVE (ALTERNATE CONSTRUCTION-FACTORY INSTALLED)
- HGBS HOT GAS BYPASS SOLENOID (ALTERNATE CONSTRUCTION-FACTORY INSTALLED)



D 64279

**Figure 11**  
**Unit Refrigeration Schematic for CGA 180B Units**

NOTES: 1. CIRCUITS THROUGH THE CONDENSER COIL ARE NOT SHOWN.

**SYMBOL DEFINITION**

- PRESSURE GAGE CONNECTION
- LPCO LOW PRESSURE CONTROL CONNECTION
- HPCO HIGH PRESSURE CONTROL CONNECTION
- TXV THERMAL EXPANSION VALVE
- HGBS HOT GAS BYPASS SOLENOID (ALTERNATE CONSTRUCTION—FACTORY INSTALLED)
- HGBP HOT GAS BYPASS VALVE (ALTERNATE CONSTRUCTION—FACTORY INSTALLED)

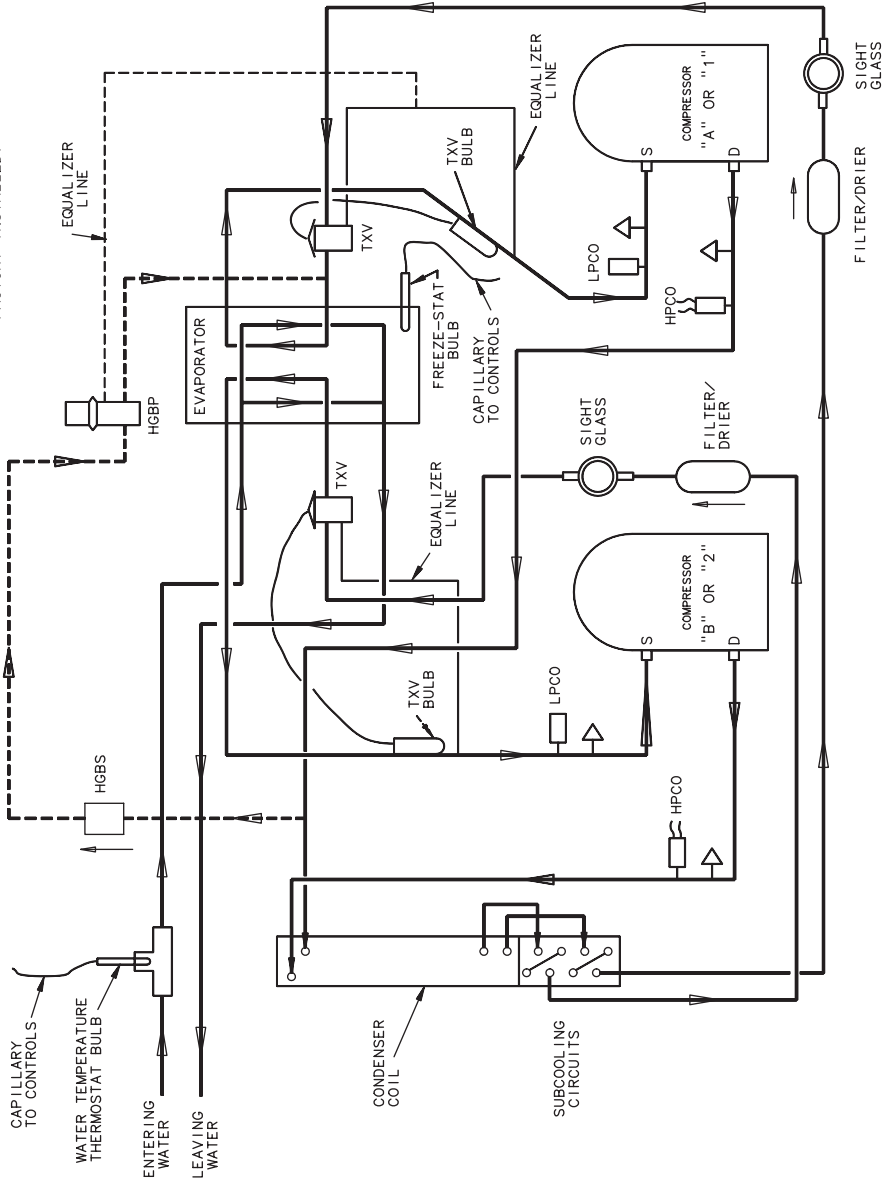

C664280

# Maintenance

## Periodic Maintenance

Perform all of the indicated maintenance procedures at the intervals scheduled. This will prolong the life of the unit and reduce the possibility of costly equipment failure.

---

**Note:** Use an "Operator's Log" (such as the one in this manual) to record a weekly operating conditions history for the unit. This operating log can be a valuable diagnostic tool for service personnel; by noticing trends in operating conditions, the operator can often foresee and prevent problem situations before they become serious.

---

If the unit does not perform properly during any of these maintenance inspections, consult the "Trouble Analysis" section of this manual for possible causes and recommended repairs.

## Weekly Maintenance

Once the unit has been operating for about 30 minutes and the system has stabilized, check operating conditions and complete the checkout procedure described below:

- [ ] Check suction and discharge pressures. (Refer to "Checking Operating Conditions").
- [ ] Check the liquid line sight glasses/moisture indicators. (Refer to "Checking Operating Conditions").
- [ ] If operating pressures and sight glass/moisture indicator conditions indicate a refrigerant shortage, measure system superheat and system subcooling. (Refer to "Checking Operating Conditions").
- [ ] If operating conditions indicate an overcharge, slowly (to minimize oil loss) recover refrigerant at the liquid line service valve.

---

**Important Note:** *Do NOT release refrigerant into the atmosphere! Refer to general service bulletin MSCU-SB-1 (latest edition.)*

---

## CAUTION:

TO PREVENT INJURY DUE TO FROSTBITE, AVOID SKIN CONTACT WITH REFRIGERANT.

---

- [ ] Inspect the entire system for unusual conditions and inspect coils for dirt and debris. If coils are dirty, clean them. (Refer to "Coil Cleaning").

---

**Note:** Use an operating log (such as the one in this manual) to record a weekly operating conditions history for the unit. A complete operating log is a valuable diagnostic tool for service personnel.

---

## Monthly Maintenance

- [ ] Perform all weekly maintenance procedures.
- [ ] Measure and record system superheat.

- [ ] Measure and record system subcooling.
- [ ] Open the unit disconnect switch; then manually rotate the outdoor fans to ensure proper orifice clearance.

**WARNING: MORE THAN ONE DISCONNECT MAY BE REQUIRED TO DE-ENERGIZE UNIT FOR SERVICING. REFER TO UNIT SCHEMATIC AND OPEN ALL ELECTRICAL DISCONNECTS TO PREVENT INJURY OR DEATH DUE TO ELECTRICAL SHOCK.**

- [ ] Inspect the fan mounting bolts for tightness.
- [ ] Check fan set screws for tightness.

## Annual Maintenance

- [ ] Perform all weekly and monthly maintenance procedures.
- [ ] Have a qualified service technician check the setting and function of each control and inspect the condition of all contactors and replace as necessary.
- [ ] If the chiller is not piped to drain facilities, make sure the drain is clear to carry away system water.
- [ ] Drain water from evaporator and associated piping systems. Inspect all piping components for leakage, damage, etc. Clean out any in-line water strainers.
- [ ] Clean and repaint any corroded surfaces.
- [ ] Clean condenser coils. (Refer to "Coil Cleaning").
- [ ] Inspect the expansion valve sensing bulbs for cleanliness; clean if required. These sensing bulbs must make good contact with the suction lines, and must be properly insulated.
- [ ] Determine whether or not lubrication of the outdoor fan motor bearings is needed; lubricate bearings with a light-weight oil (e.g. SAE-20 non-detergent or equivalent), if necessary.

---

**NOTE:** CGA outdoor fan motor assemblies are permanently lubricated and usually do not require additional oiling unless the unit is installed in a "dirty" environment. Under such conditions, lubricate the fan motor bearings after every 10,000 hours of operation. Do not over-lubricate!

---

- [ ] Clean condenser fans.

## Maintenance Procedures

This section describes specific maintenance procedure(s) which must be performed as a part of the normal maintenance program for this unit. Be certain that electrical power to the unit is disconnected before performing these procedures.

---

### **WARNING:** **HAZARDOUS VOLTAGE!**

**DISCONNECT ALL ELECTRIC POWER INCLUDING REMOTE DISCONNECTS BEFORE SERVICING.**

**Failure to disconnect power before servicing can cause severe personal injury or death.**

---

#### Coil Cleaning

Clean the condenser refrigerant coil at least once each year (or more frequently if the unit is located in a "dirty" environment) to help maintain proper unit operating efficiency. Specific instructions for cleaning refrigerant coils are outlined below. Follow these instructions as closely as possible to avoid potential damage to the coils.

To clean the refrigerant coil, a soft brush and sprayer (i.e., either a garden pump-up type, or a high-pressure sprayer) must be used. In addition, a high-quality detergent is required; suggested brands include "SPREX A.C.", "OAKITE 161", "OAKITE 166", AND "COILOX".

**Note: If the detergent is strongly alkaline (i.e., has a pH value greater than 8.5) after mixing, an inhibitor must be added.**

---

#### Cleaning Procedure:

1. Disconnect power to the unit.

---

### **WARNING:** **HAZARDOUS VOLTAGE!**

**DISCONNECT ALL ELECTRIC POWER INCLUDING REMOTE DISCONNECTS BEFORE SERVICING.**

**Failure to disconnect power before servicing can cause severe personal injury or death.**

---

2. Remove enough panels and components from the unit to gain access to the condenser coils.
3. Protect all electrical devices such as motors and controls from dust and water.
4. Straighten coil fins with a fin rake, if necessary.
5. Use a soft brush to remove loose dirt and debris from both sides of the coil.

## Maintenance

---

6. Mix the detergent with water according to the manufacturer's instructions. To improve the cleansing ability of the solution, heat it to a maximum of 150 F.

---

### **CAUTION:** **CONTAINS REFRIGERANT!**

**SYSTEM CONTAINS OIL AND REFRIGERANT**

**Do not heat the detergent-and-water solution above 150° F. Hot liquids sprayed on the exterior of the coil will raise the coil's internal pressure and may cause it to burst.**

**Failure to follow proper procedures can result in personal illness or injury or severe equipment damage.**

---

7. Place the cleaning solution in the sprayer. Be sure to follow these guidelines if a high-pressure sprayer is used: (1) minimum nozzle spray angle is 15 degrees; (2) spray solution at 90 degrees to the coil face; (3) keep spray nozzle at least six inches from the coil; and, (4) sprayer pressure must not exceed 600 psi.
8. Spray the leaving air side of the coil first; then spray the entering air side of the coil. Allow the detergent-and-water solution to stand on the coil for 5 minutes.
9. Rinse both sides of the coil with cool, clean water.
10. Inspect the condenser coil. If it still appears to be dirty, repeat Steps 7 and 8.
11. Remove protective covers installed in Step 3.
12. Reinstall all unit components and panels; then restore electrical power to the unit.

#### Cleaning the Evaporator

The chilled water system is a closed loop. It should not accumulate a large amount of scale or sludge. If the chiller is fouled, first try to dislodge foreign material by back-flushing the system several times. If this does not work, take a water sample from the evaporator and analyze it. Determine treatment based on the findings.

---

### **CAUTION:**

**DO NOT USE ACIDIC TYPE CLEANING AGENT THAT WILL DAMAGE THE INTERNAL EVAPORATOR COMPONENTS.**

---

#### Water Treatment

The use of untreated or improperly treated water in these units may result in the formation of scale, erosion, corrosion, algae or slime. It is recommended that the services of a qualified water treatment specialist be engaged to determine what treatment, if any, is required. The Trane Company assumes no responsibility for equipment failure that results from the use of untreated or improperly treated water.

## Low Ambient Start Timer (LAST) Checkout Procedure

To determine whether or not a low ambient start timer is defective, follow these steps:

1. Remove power from the CGA unit by operating the supply power fused disconnect switch.
2. Disable both low pressure cutouts (LPCO1 and LPCO2) by disconnecting the wires from their number 1 terminals. Tape the disconnected wires to prevent shorting.
3. Restore power to the system, energize compressor number one and check how long it runs before cutting out.
4. Remove power from the system and disable compressor number one. Tape any wires removed to prevent shorting.
5. Restore power to the system, energize compressor number two and check how long it runs before cutting out.
6. Remove power from the system and reconnect the wires removed from the low pressure cutouts in step two. Reconnect the wires that disabled compressor number one.
7. Restore power to the unit.

**Conclusion:** Compare the compressor run times verified in Steps 3 and 5 with the rated duration of the low ambient start timers. (The rated duration times are usually stamped on the timers or given in the unit literature). If the compressor run times don't match the duration times of the low ambient start timers, the timers are defective and must be replaced.

## Preliminary Troubleshooting Inspection

If operational difficulties are encountered, be sure to perform these preliminary checks before referring to the troubleshooting charts:

[ ] Check the water temperature thermostat (WTT) to ensure that it is set correctly, receiving control power, and "making/breaking" at the proper intervals.

[ ] Verify that the unit is receiving electrical supply power, and that the fuses in the fused disconnect switch(es) and main control panel are intact.

[ ] Check the evaporator for proper water supply. Check the flow switch for proper operation, and take pressure drop readings across the evaporator.

After completing the preliminary checks described above, be sure to inspect the unit for other obvious causes of trouble such as an excessively dirty condenser coil, leaking water connections, broken or disconnected wires, etc. If everything appears to be in order - but the unit still fails to operate properly - refer to the appropriate troubleshooting chart and contact a qualified service technician.

## Troubleshooting Charts

The troubleshooting charts which follow are provided to serve as an aid to identifying the cause of any system malfunctions that may occur. Within each chart are three columns: (1) the Symptom column describes the behavior the unit is exhibiting; (2) the Probable Cause column identifies the most likely sources of the malfunction; and, (3) the Recommended Action column describes the suggested action for correcting the problem.

---

***NOTE: The troubleshooting charts which follow are provided solely as a guide for determining the cause of mechanical failure or malfunction. When mechanical problems do occur, The Trane Company recommends that qualified service personnel be contacted to help ensure proper diagnosis and repair of the unit.***

---

---

### **WARNING:**

**HAZARDOUS VOLTAGE  
ROTATING PARTS!**

**UNIT STARTS AUTOMATICALLY. NEVER OPEN ACCESS PANEL(S) TO INSPECT OR SERVICE UNIT WITH FIRST OPENING UNIT DISCONNECT SWITCH(ES).**

**Make sure all personnel are standing clear of the unit before proceeding. The system components will start when the power is applied.**

---

# System Troubleshooting

SYMPTOM	PROBABLE CAUSE	RECOMMENDED ACTION
A. Compressor neither starts or hums.	1. No power to the Unit.	a. Disconnect switch open. b. Fuse(s) blown.
	2. No call for cooling.	a. Defective thermostat. b. Broken or improper control wiring. c. Blown control power fuse.
	3. Anti-short cycle times has not timed out.	Wait at least 3 minutes for the anti-short cycle timer to time out.
	4. Unit locked out by reset relay.	a. Excessive discharge pressure; see "Discharge Pressure Too High." b. Defective high pressure control. c. Low Charge; Low pressure switch open. d. Defective reset relay contact.
	5. Compressor contactor will not close.	a. Defective compressor contactor. b. Improper wiring. c. Reset relay open. d. Low pressure control open. e. Cooling relay not energized. Defective relay; check thermostat circuit. See Probable Cause #2 above.
	6. Compressor winding stat open.	See "Compressor Motor Winding Stat Open". a. Check compressor amp draw.
B. Compressor hums, but will not start.	1. Low voltage at compressor.	a. Single blown fuse. b. Low line voltage. c. Defective compressor contactor. d. Loose wiring connections.
	2. Defective compressor.	a. Open motor winding. b. Excessive amp draw on all phases.
	3. Insufficient starting Voltage (Single-Phase Unit Only)	a. Defective start capacity. b. Defective start relay.
C. 2nd stage compressor fails to start.	1. Time delay contacts fail to close.	Replace time delay relay.
	2. No call for cooling.	a. Defective thermostat. b. Broken or improper control wiring.
	3. Unit locked out by reset relay.	See Symptom A, Probable Cause #4.
	4. Compressor contactor will not close.	See Symptom A, Probable Cause #5.
D. Compressor short cycles.	1. Intermittent contact in control circuit.	a. Defective relay contacts. b. Loose wiring connections.
E. Compressor runs continuously.	1. Unit undersized for load (cannot maintain water temperature).	Check for cause of excessive load.
	2. Thermostat setpoint too low.	Re-adjust thermostat.
	3. Defective thermostat or control wiring.	Replace thermostat. Replace or repair control wiring.
	4. Welded contacts on compressor contactor.	Replace or repair contactor.
	5. Leaky valves in compressor (indicated by abnormally low discharge and high suction pressures).	Replace compressor.
	6. Shortage of refrigerant (indicated by reduced capacity, high super-heat, low subcooling, and low suction pressure).	Find and repair refrigerant leak. Recharge system.

# System Troubleshooting

SYMPTOM	PROBABLE CAUSE	RECOMMENDED ACTION
F. Compressor motor winding stat open.	1. Excessive load on evaporator (indicated by high supply water temperature).	a. Excessive water flow. b. High return water temperature.
	2. Lack of motor cooling (indicated by excessive superheat).	a. Improper expansion valve setting. b. Faulty expansion valve. c. Restriction in liquid line.
	3. Improper voltage at compressor.	a. Low or imbalanced line voltage. b. Loose power wiring. c. Defective compressor contactor.
	4. Internal parts of compressor damaged.	Replace compressor.
G. Compressor is noisy.	1. Internal parts of compressor damaged or broken (compressor knocks).	Replace compressor.
	2. Liquid floodback (indicated by abnormally cold suction line and low superheat).	Check and adjust superheat.
	3. Liquid refrigerant in compressor at start-up (indicated by abnormally cold compressor shell).	Check crankcase heater. Check for refrigerant overcharge.
H. System short of capacity.	1. Low refrigerant charge (indicated by high superheat and low sub-cooling).	Add refrigerant.
	2. Clogged filter drier (indicated by temperature change in refrigerant line thru drier).	Replace filter drier or filter drier core.
	3. Incorrect expansion valve setting.	Re-adjust expansion valve.
	4. Expansion valve stuck or obstructed (i.e., high high superheat and high water temperature).	Repair or replace expansion valve.
	5. Low evaporator water flow.	Check strainers. Adjust water flow.
	6. Non-condensibles in system.	Evacuate and re-charge system.
	7. Leaky valve in compressor (i.e., operation at abnormally high suction and low discharge pressure).	Replace compressor.

# System Troubleshooting

SYMPTOM	PROBABLE CAUSE	RECOMMENDED ACTION
I. Suction pressure too low.	1. Shortage of refrigerant (i.e., high superheat, low subcooling).	Find and repair leak; re-charge system.
	2. Thermostat set too low (i.e., low discharge pressure, low leaving water temperature).	Re-adjust thermostat.
	3. Low water flow.	Check for clogged strainers and incorrect balancing valve settings.
	4. Clogged filter drier.	Check for frost on filter drier. Replace if needed.
	5. Expansion valve power assembly has lost charge.	Repair or replace expansion valve power head assembly.
	6. Obstructed expansion valve (i.e., high superheat).	Clean or replace valve.
J. Suction pressure too high.	1. Excessive cooling load (i.e., high supply water temperatures).	See Symptom E.
	2. Expansion valve over-feeling (i.e., superheat too low, liquid flooding to compressor).	Adjust superheat setting; verify that remote bulb is properly attached to suction line.
K. Discharge pressure too low.	1. Shortage of refrigerant (i.e., low subcooling, high superheat, bubbles in sight glass).	Find and repair leak; re-charge system.
	2. Broken or leaky compressor discharge valve.	Replace compressor.
	3. Defective low pressure switch.	Replace defective control.
	4. Unit running below minimum operating ambient.	Provide adequate heat pressure controls, or an ambient lockout switch.
L. Discharge pressure too high.	1. Too little or too warm condenser air; airflow restricted.	Clean coil; check fans and motor for proper function.
	2. Air or non-condensable gas in system (i.e., exceptionally hot condenser).	Evacuate and re-charge system.
	3. Refrigerant overcharge (i.e., high subcooling, low superheat, high suction pressure).	Re-cover excess refrigerant.
	4. Excessive system load.	Reduce load.
	5. Defective condenser fan or fan pressure control (i.e., 1 fan off, high condenser pressure).	Repair or replace switch.



