



# Air-Cooled Liquid Chillers

---

10 to 60Tons





## Introduction

---

# Air-Cooled Liquid Chillers

Design and manufacturing excellence makes Trane a leader in the air-cooled chiller marketplace. For over 40 years, Trane has been using the best engineering available in development, manufacturing, and marketing to

produce quality products. This tradition of using excellence to meet market demands is illustrated with the Trane 10 through 60-ton air-cooled chillers.



*10, 15 Tons*



*20-60 Tons*

# Contents

---

<b>Introduction</b>	<b>2</b>
<b>Features and Benefits</b>	<b>4</b>
<b>Application Considerations</b>	<b>9</b>
<b>Selection Procedure</b>	<b>14</b>
Model Number Description	15
<b>General Data</b>	<b>16</b>
<b>Performance Data</b>	<b>21</b>
Performance Adjustment Factors	17
<b>Controls</b>	<b>30</b>
<b>Electric Power</b>	<b>37</b>
<b>Dimension and Weights</b>	<b>39</b>
<b>Mechanical Specifications</b>	<b>48</b>



# Features and Benefits

(10-60 Ton)

### Installation

Small size, complete factory wiring, easy lifting provisions, factory installed options and start-up control provide fast, easy installation. A complete factory run test is performed on each unit, eliminating potential start-up problems.

### Integrated Comfort™ Systems

All Trane chillers are ICS compatible. A simple twisted wire pair is all it takes to hook an air-cooled chiller into a Tracer® system. An ICS system provides the most advanced diagnostics, monitoring, and control that the industry can offer. Only Trane can supply the entire package. ICS provides comfort with one word - Trane.

### Packed Stock Increases Project Flexibility

Trane 10 through 60-ton air-cooled chillers are available through the most flexible packed stock program in the industry.

Trane knows you want your units on the jobsite, on time, when you need them. To help meet this demand, Trane keeps a multitude of unit sizes and voltages in packed stock. Many of these include optional features such as isolators, low ambient head pressure controls and refrigerant gauge piping.

You no longer have to settle for a scaled-down, basic unit to meet your job schedule. In many cases, units can be shipped directly to the jobsite from packed stock!



# Features and Benefits

(10-15 Ton)

The 10 and 15-ton air-cooled Cold Generator® chillers, with Trane direct drive hermetic scroll compressors, has outstanding standard features and additional benefits that make selection, installation, and servicing easy.

## Flexibility

### Footprint

Central to the design of any project is the operating envelope of the air-cooled packaged chiller. With this in mind, Trane builds the chillers to make the most efficient use of the available installation space. The Trane CGA model chillers are extremely compact. They have the lightest weight, the smallest footprint, and the lowest silhouette of any chiller in the industry.

### Less Weight

These lightweight models afford less stress on building supports and greater handling ease.

### Installation

Installation time and effort are reduced when dealing with a significantly smaller and lighter unit. In addition, having electrical and water connections on the same side of the unit and a single-point main power connection serves to make installation easier. The unit arrives at the jobsite fully assembled, tested, charged and ready to provide chilled water.

### Ease of Service

The control panel and unit panels are completely removable for service accessibility and convenience.

### ICS Interface

Communication with Trane Tracer® or Tracker® is possible through the ICS Interface on the 10 and 15 ton Cold Generator chiller.

## Optional Features

- **Hot Gas Bypass** –Allows unit operation below the minimum step of unloading.
- **Low Ambient Head Pressure Control** –Modulates the rpm of the fan motor in response to outdoor ambient temperature and unit head pressure. Provides unit cooling operation down to outdoor temperatures of 0°F.
- **Coil Guard** –Metal grille with PVC coating to protect the condenser coil.
- **Isolation** –Neoprene in shear or spring flex isolators.
- **Power Supply Monitor** –Provides protection against phase loss, phase reversal, phase imbalance, incorrect phase sequence and low line voltage.

- **Elapsed Time Meter/Number Starts Counter** –Records number of compressor starts and operating hours.
- **Flow Switch** –Required as a safety interlock to prevent operation of unit without evaporator flow (available option for field installation only).
- **Integrated Comfort™ Systems (ICS) Interface** –Provides the ability to communicate with Trane Tracer® or Tracker® building management systems via a Thermostat Control Module –(TCM).
- **Gauges** –Monitor suction and discharge pressures.





# Features and Benefits

(20-60 Ton)

Trane's 20-60 ton chillers offer the same time-tested and proven control technology that is applied to the IntelliPak™ Air Cooled rooftops.

Superior control makes the IntelliPak a *truly advanced chiller*.

## Standard Features

### Microprocessor Control

The IntelliPak chiller's Unit Control Module (UCM) is an innovative, modular microprocessor control design. It coordinates the actions of the chiller in an efficient manner and provides stand-alone operation of the unit. A Human Interface (HI) Panel is a standard component of the IntelliPak Chiller. Access to all unit controls is via the Human Interface Panel.

### Factory Run Testing

In addition to outstanding efficient performance, IntelliPak Chillers have established a reputation for reliable operation. Aside from the individual component tests, all Trane 20 through 60-ton chillers are factory run tested with water running through the evaporator to confirm proper operation. Control operation and current draw are both monitored to assure safe, reliable operation.

## Other Standard Features

- Trane 3-D™ Scroll compressors
- Advanced motor protection
- 300 psi waterside evaporator
- Evaporator insulation (¾-inch Armaflex II or equivalent)
- Evaporator heat tape (thermostat controlled)
- Condenser coil guards
- Operation down to 30°F without additional wind baffles or head pressure control
- Loss of flow protection
- UL and CSA approval available
- Packed stock availability
- Control Power Transformer
- Low ambient lockout
- Plain English (Spanish/French) Human Interface display
- Smart Lead/Lag operation
- Integrated chilled solution pump control
- Selectable process or comfort control algorithm
- External auto/stop
- Electronic low ambient damper control integrated into UCM

## Optional Features

- Controls for ice making operation

## Miscellaneous Options

- Trane Communications Interface Module (TCI)
- Unit Mounted Disconnect
- Isolators
- Superheat/Sub-Cooling Module
- Hot Gas Bypass
- Generic B A S Modules with 0-10 v. analog input/output, 0-5 v analog input/binary output
- Remote Human Interface Panel (RHI)
- Remote Setpoint Potentiometer
- Zone Sensor (Chilled Solution Reset)
- Flow Switch
- Copper Fin Condenser Coils
- Electronic Low Ambient Damper(s)
- Inter-Processor Communication Bridge (IPCB)
- Ice building control
- Other Options

In addition to all of these options, Trane can offer in-house design for many applications, including special coil coating.



# Features and Benefits

(20-60 Ton)

## Enhanced Controls

### IntelliPak™ Chiller Unit Control Module (UCM)

#### Microprocessor Control

The brain of the 20 through 60 ton air-cooled chiller is its Unit Control Module (UCM). The UCM is an innovative, modular microprocessor control design, which coordinates the actions of the chiller in an efficient manner, providing stand-alone operation of the unit.

Access to the unit controls is via a Human Interface (HI) Panel, a standard component of the IntelliPak chiller. This panel provides a high degree of control. Superior monitoring capability and unmatched diagnostic information is provided through a 2 line 40 character per line, English language display. There are no diagnostic "codes" requiring a translation key for interpretation. All system status information and control adjustments can be made from the onboard Human Interface Panel.

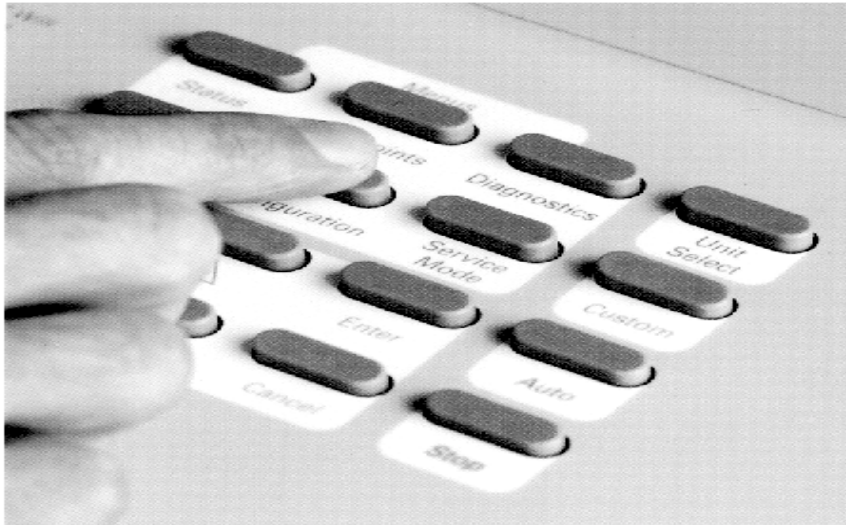

Remote Human Interface (RHI) – The optional Remote Human Interface (RHI) performs the same functions as the Human Interface, with the exception of the service mode. The RHI can be used with up to 4 air-cooled chillers from a single panel.

## The Integrated Comfort™ System — The Industry's Most Advanced Comfort System

The UCM allows the 20 through 60-ton IntelliPak® chiller to be part of the factory installed Integrated Comfort System (ICS). ICS joins the Trane Tracer® building management systems and Trane HVAC equipment by a single twisted wire pair. This allows bidirectional communication between the Tracer system and the unit mounted controls. Connected to the chiller's UCM, this simple pair allows you to control, monitor, and diagnose your building's comfort system. The UCM is linked to the Tracer system and they electronically "talk" to one another.

Since ICS is factory-packaged, there is no need to install separate sensors to monitor your chiller's operation. All of the control points are on the controller and ready to go when the unit ships. Simply hook-up the Tracer system to the IntelliPak® chiller with the twisted wire pair. This feature means lower installed cost, less chance for jobsite errors, less design time on the front end of your project, and fewer callbacks.

ICS gives you the most powerful monitoring and diagnostic system available. Monitoring up to 30 individual points, the ICS can detect and correct problems before a comfort level change is even noticed. Advanced monitoring and diagnostics can help building owners to more effectively market their buildings to prospective tenants.

An ICS system is the most advanced comfort system in the industry. Because Trane has more experience with ICS than all other equipment manufacturers combined, you can feel secure knowing that you are dealing with a proven track record in building management. Trane is the only brand that supplies the entire package.

### Tracer control points for IntelliPak Chillers

- Chilled solution setpoint
- Default chilled solution setpoint
- Ice Setpoint
- Default Ice Setpoint
- Chiller enable point
- Failure mode
- Ice making enable point
- KW limit enable point
- Demand limiting cooling stages
- Default number of compressors
- Design delta temperature
- Control response setpoint
- Reset Option



# Features and Benefits

(20-60 Ton)

## Trane 3-D™ Scroll Compressor Simple Design with 70% Fewer Parts

Fewer parts than an equal capacity reciprocating compressor means significant reliability and efficiency benefits. The single orbiting scroll eliminates the need for pistons, connecting rods, wrist pins and valves. Fewer parts lead to increased reliability. Fewer moving parts, less rotating mass and less internal friction means greater efficiency than reciprocating compressors.

The Trane 3-D Scroll provides important reliability and efficiency benefits. The 3-D Scroll allows the orbiting scrolls to touch in all three dimensions, forming a completely enclosed compression chamber which leads to increased efficiency. In addition, the orbiting scrolls only touch with enough force to create a seal; there is no wear between the scroll plates. The fixed and orbiting scrolls are made of high strength cast iron which results in less thermal distortion, less leakage, and higher efficiencies. The most outstanding feature of the 3-D Scroll compressor is that slugging will not cause failure. In a reciprocating compressor, however, the liquid or dirt can cause serious damage.

### Low Torque Variation

The 3-D Scroll compressor has a very smooth compression cycle; torque variations are only 30 percent of that produced by a reciprocating compressor. This means that the scroll compressor imposes very little stress on the motor resulting in greater reliability. Low torque variation reduces noise and vibration.

### Suction Gas Cooled Motor

Compressor motor efficiency and reliability is further optimized with the latest scroll design. Cool suction gas keeps the motor cooler for longer life and better efficiency.

## Proven Design Through Testing and Research

With over twenty years of development and testing, Trane 3-D Scroll compressors have undergone more

than 400,000 hours of laboratory testing and field operation. This work combined with over 25 patents makes Trane the worldwide leader in air conditioning scroll compressor technology.

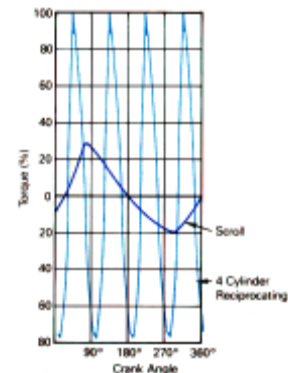
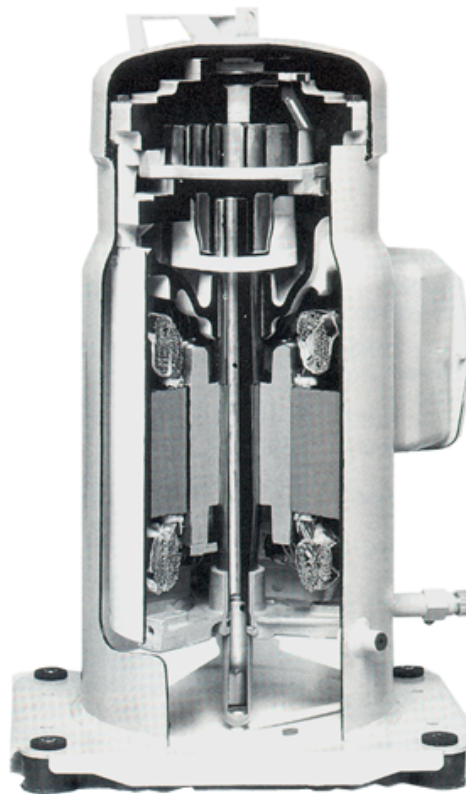

One of two matched scroll plates — the distinguishing feature of the scroll compressor.

Chart illustrates low torque variation of 3-D Scroll compressor vs reciprocating compressor.

# Application Considerations

Certain application constraints should be considered when sizing, selecting and installing Trane™ air-cooled chillers. Unit and system reliability is often dependent upon proper and complete compliance with these considerations. Where the application varies from the guidelines presented, it should be reviewed with your local Trane sales engineer.

Note: The terms water and solution are used interchangeably in the following paragraphs.

## UNIT SIZING

Unit capacities are listed in the “Performance Data” section. Intentionally oversizing a unit to assure adequate capacity is not recommended. Erratic system operation and excessive compressor cycling are often a direct result of an oversized chiller. In addition, an oversized unit is usually more expensive to purchase, install, and operate. If oversizing is desired, consider using two units.

## UNIT PLACEMENT

1

### Setting The Unit

A base or foundation is not required if the selected unit location is level and strong enough to support the unit's operating weight (see “Weights” section of this catalog).

For a detailed discussion of base and foundation construction, refer to the Trane Reciprocating Refrigeration Manual. Manuals are available through the local Trane office.

2

### Isolation and Sound Emission

The most effective form of isolation is to locate the unit away from any sound sensitive area. Structurally transmitted sound can be reduced by using spring isolators. Spring isolators are generally effective in reducing vibratory noise generated by compressors, and therefore, are recommended for sound sensitive installations. An acoustical engineer should always be consulted on critical applications.

For maximum isolation effect, water lines and electrical conduit should also be isolated. Wall sleeves and rubber isolated piping hangers can be used to reduce the sound transmitted through water piping. To reduce the sound transmitted through electrical conduit, use flexible electrical conduit.

State and local codes on sound emissions should always be considered. Since the environment in which a sound source is located affects sound pressure, unit placement must be carefully evaluated. Sound pressure and sound power levels for chillers are available on request.

3

### Servicing

Adequate clearance for evaporator and compressor servicing should be provided. Recommended minimum space envelopes for servicing are located in the dimensional data section and can serve as a guideline for providing adequate clearance. The minimum space envelopes also allow for control panel door swing and routing maintenance requirements. Local code requirements may take precedence.

4

### Unit Location

a

#### General

Unobstructed flow of condenser air is essential to maintain chiller capacity and operating efficiency. When determining unit placement, careful consideration must be given to assure a sufficient flow of air across the condenser heat transfer surface. Two detrimental conditions are possible and must be avoided: warm air recirculation and coil starvation.

Warm air recirculation occurs when discharge air from the condenser fans is recycled back to the condenser coil inlet. Coil starvation occurs when free airflow to the condenser is restricted.

Condenser coils and fan discharge must be kept free of snow or other obstructions to permit adequate airflow for satisfactory unit operation.

Debris, trash, supplies, etc., should not be allowed to accumulate in the vicinity of the air-cooled chiller. Supply air movement may draw debris into the condenser coil, blocking spaces between coil fins and causing coil starvation.

Both warm air recirculation and coil starvation cause reductions in unit efficiency and capacity because of the higher head pressures associated with them. In addition, in more severe cases, nuisance unit shutdowns will result from excessive head pressures. Estimates of the degree of efficiency and capacity reduction in such situations can be determined. Consult your local Trane sales engineer.

Cross winds, those perpendicular to the condenser, tend to aid efficient operation in warmer ambient conditions, however, they tend to be detrimental to operation in lower ambients or when hot gas bypass is used due to the accompanying loss of adequate head pressure. As a result, it is advisable to protect air-cooled chillers from continuous direct winds exceeding 10 miles per hour in low ambient conditions.

### Low Ambient Operation — 20-60 Ton models — Human Interface Recommendations

When the temperature outside is sub-zero, who wants to be out there monitoring or troubleshooting diagnostics? Because we understand a service technician's reluctance to do this, we recommend using a Remote Human Interface (RHI) panel. The service technician can troubleshoot and diagnose in the comfort of a mechanical room.

# Application Considerations

**b**  
**Provide Vertical Clearance**

Vertical condenser air discharge must be unobstructed. While it is difficult to predict the degree of warm air recirculation, a unit installed as shown below would have its capacity and efficiency significantly reduced – possibly to the degree of nuisance high head pressure tripouts. Performance data is based on free air discharge.

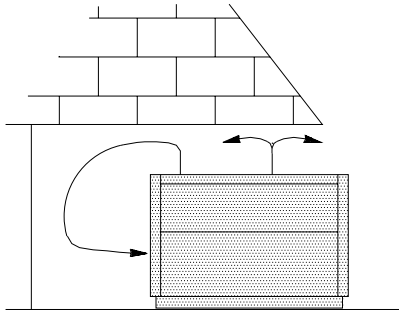

**c**  
**Provide Lateral Clearance**

The condenser coil inlet must not be obstructed. A unit installed closer than the minimum recommended distance to a wall or other vertical riser may experience a combination of coil starvation and warm air recirculation, resulting in unit capacity and efficiency reductions and possible excessive head pressures.

The recommended lateral clearances are depicted in the dimensional data section. These are estimates and should be reviewed with the local Trane sales engineer at the jobsite.

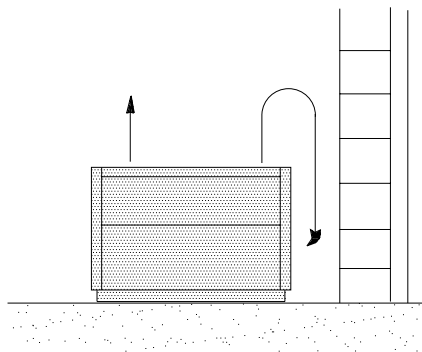

**d**  
**Provide Sufficient Unit-to-Unit Clearance**

Units should be separated from each other by sufficient distance to prevent warm air recirculation or coil starvation. Doubling the recommended single unit air-cooled chiller clearances will generally prove to be adequate.

**e**  
**Walled Enclosure Installations**

When the unit is placed in an enclosure or small depression, the top of the fans should be no lower than the top of the enclosure or depression. If they are, consideration should be given to ducting the top of the unit. Ducting individual fans, however, is not recommended. Such applications should always be reviewed with the local Trane sales engineer.

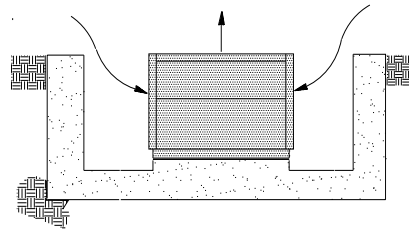

**VOLTAGE**

Nominal voltage is the nameplate rating voltage. The actual range of line voltages at which the equipment can satisfactorily operate are given below.

Rated Voltage	Voltage Utilization Range
200	180-220
208-230	187-253
230	208-254
380	342-418
400	360-440
415	374-456
460	414-508
575	520-635

**WATER TREATMENT**

Dirt, scale, products of corrosion, and other foreign material in the water will adversely affect heat transfer between the water and system components. Foreign matter in the chilled water system can also increase pressure drop and, consequently, reduce waterflow. Proper water treatment must be determined locally and depends on the type of system and local water characteristics.

Do not use salt or brackish water in Trane chillers. Use of either will lead to a shortened life. Trane encourages the employment of a reputable water treatment specialist, familiar with local water conditions, to assist in the establishment of a proper water treatment program.

The capacities given in the "Performance Data" section of this catalog are based on water with a fouling factor of 0.0001 (in accordance with ARI 550/590-98). For capacities at other fouling factors, see "Performance Adjustment Factors" section of this catalog.

**EFFECT OF ALTITUDE ON CAPACITY**

Chiller capacities given in the "Performance Data" section are based upon application at sea level. At elevations substantially above sea level, the decreased air density will decrease condenser capacity and, therefore, unit capacity and efficiency. The adjustment factors in the "Performance Adjustment Factors" section of this catalog can be applied directly to the performance data to determine the unit's adjusted performance.

# Application Considerations

## AMBIENT LIMITATIONS

Trane chillers are designed for year-round applications in ambients from 0° F to 115° F. For operation below 0° F or above 115° F, contact the local Trane sales office. If hot gas bypass is used, operating ambients vary depending upon unit size (see the "General Data" section of this catalog).

1

### Low Ambient Operation

Start-up and operation of Trane chillers at lower ambient temperatures require that sufficient head pressure be maintained for proper expansion valve operation.

Minimum operating ambient temperatures for standard unit selections and units with hot gas bypass are shown in the "General Data" section of this catalog.

Minimum ambient temperatures are based on still conditions (winds not exceeding five mph). Greater wind velocities will result in a drop in head pressure, therefore increasing the minimum starting and operating ambient temperatures.

Optional low ambient units use a electronic low ambient damper control (20-60 tons) or a variable speed fan motor (10-15 tons) arrangement to control condenser capacity by modulating condenser fans in response to refrigerant pressure.

2

### High Ambient Operation

Maximum cataloged ambient temperature operation of a standard Trane chiller is 115° F. Operation at design ambients above 115° F can result in excessive head pressures. For operation above 115° F, contact your local Trane sales office.

## CONTROLS

1

### Temperature Controller

In order to provide stable system operation and to prevent excessive compressor cycling, the temperature control sensor in all 20-60 ton chillers is located in the supply (outlet) solution. The temperature sensor in all 10 and 15 ton chillers is located in the return (inlet) solution. This sensor cannot be relocated. Doing so would result in improper unit operation.

2

### Anti-recycle Timer/Fixed-Off Timer

All IntelliPak air-cooled chillers come standard with Anti-recycle/Fixed Off Timers. This function prevents rapid cycling of the compressors due to low load conditions or short water loops.

3

### Pumpdown

CGAF air-cooled chillers will pumpdown, if function is enabled, when a refrigerant circuit is turned off. All of the refrigerant is pumped into the condenser. A solenoid valve provides a positive shutoff between the condenser and the evaporator, allowing little or no refrigerant migration to the evaporator during "off" periods.

4

### Hot Gas Bypass

Hot gas bypass provides more stable leaving solution temperature control at light load conditions. The compressor runs continuously for a user-defined run time. Minimum starting and operating ambients with hot gas bypass are shown in the "General Data" section of this catalog. The hot gas bypass reduces the unit head pressure, thereby increasing the minimum operating ambient.

5

### Loss of Flow Protection

Loss of flow may result in evaporator freeze up. Full chilled solution flow must be maintained through the evaporator while compressors are operating.

A flow switch used as a safety interlock is always recommended for CGA units.

The CGAF air-cooled chiller has a system which senses a loss of flow condition and shuts the unit down. The CGAF's microcomputer is automatically reset for the unit to resume operation. A set of contacts is available for externally starting and stopping the pump.

## WATERFLOW LIMITS

The minimum water flow rates are given in the "General Data" section of this catalog. Evaporator flow rates below the tabulated values will result in laminar flow causing scaling, stratification, freeze-up problems, and poor temperature control.

The maximum evaporator water flow rate is given in the "General Data" section. Flow rates exceeding those listed will result in excessive tube erosion and very high pressure drop across the evaporator.

Trane recommends that constant water flow be maintained at all times through the evaporator. Because the temperature controller strictly senses temperature, variable flow through the evaporator may result in loss of control and localized freezing or nuisance low temperature cutouts. Consult your local Trane sales engineer if your application requires varying flows.

## TEMPERATURE LIMITS

1

### Leaving Solution Temperature range

The minimum leaving solution temperature setpoint is dependent on the number of capacity stages and the temperature difference across the evaporator. Water supply temperature setpoints less than these values result in suction temperatures at or below the freezing point of cold water.

A glycol solution is required for operation below the recommended minimum setpoints. Refer to the "Performance Adjustment Factors" section of this catalog to determine the minimum leaving chilled solution



# Application Considerations

setpoint and adequate ethylene glycol concentration for safe operation.

The maximum catalog leaving solution temperature from the evaporator is 65°F for outdoor ambients up to 115°F. High leaving water temperatures exceeding this may result in excessive suction temperatures and, therefore, inadequate motor cooling. For applications requiring high leaving water temperatures, contact your local Trane sales office for suggested alternatives.

The maximum water temperature that can be circulated through an evaporator, when the unit is not operating, is 108°F (100°F for CGA 8, 10, 12½ and 15 ton chillers). The evaporator becomes thermal stress limited at these temperatures.

## 2

### Supply Water Temperature Drop

The performance data for Trane chillers is based on a chilled water temperature drop of 10°F. Temperature drops outside this range will result in unit performance that differs from that cataloged. For performance data outside the 10°F range see the "Performance Adjustment Factors" section in this catalog. Chilled water temperature drops from 6 to 18°F (8 to 12°F in CGA units) may be used as long as minimum and maximum water temperature and minimum and maximum flow rates are not violated.

Temperature drops outside 6 to 18°F (8 to 12°F in CGA units) are beyond the optimum range for control and may adversely affect the controller's capability to maintain an acceptable supply water temperature range.

Further, temperature drops of less than 6°F may result in inadequate refrigerant superheat. Sufficient superheat is always a primary concern in any direct

expansion refrigeration system and is especially important in a package chiller where the evaporator is closely coupled to the compressor. When temperature drops are less than 6°F, an evaporator runaround loop may be required.

### TYPICAL WATER PIPING

All building water piping must be flushed prior to making final connections to the chiller. To reduce heat loss and prevent condensation, insulation should be applied. Expansion tanks are also usually required so that chilled water volume changes can be accommodated. A typical piping arrangement is shown on the following page.

### SHORT WATER LOOPS

The proper location of the temperature control sensor is in the supply (outlet) water for 20-60 ton chillers and in the return (inlet) water for 8, 10, 12½ and 15 ton chillers. This location allows the building to act as a buffer and assures a slowly changing return water temperature. If there is not a sufficient volume of water in the system to provide an adequate buffer, temperature control can be lost, resulting in erratic system operation and excessive compressor cycling. A short water loop (less than one minute in duration) will lead to erratic system operation.

To prevent the effect of a short water loop, the following items should be given careful consideration:

#### 1

Add a storage tank or larger header pipe to increase the volume of water in the system and, therefore, reduce the rate of change of the return water temperature.

#### 2

Use three-way modulating valves in lieu of two-position valves with crossover pipes at the airside evaporators. The three-way valves will reduce the rate of change in the return water temperature.

#### 3

Hot gas bypass to prevent compressor cycling at rapidly changing supply water temperatures at low load conditions.

### MULTIPLE UNIT OPERATION

Whenever two or more units are used on one chilled water loop, Trane recommends that their operation be controlled from a single control device, such as a Trane Tracer™ system. The "Stand-alone" alternative is the DDC Chiller Sequencer.

#### 1

### Series Operation

Some systems require large chilled water temperature drops (16 to 24°F). For those installations, two units with their evaporators in series are usually required. Control of the units should be from a common temperature sensor to prevent the separate unit controls from fighting one another and continually hunting. It is possible to control water temperature from the two individual unit controls, but a common temperature controller provides a positive method for preventing control overlap, more closely matching system load and simplifying compressor lead-lag capability.

#### 2

### Parallel Operation

Some systems require more capacity or standby capability than a single machine can provide. For those installations, two units with their evaporators in a parallel configuration are typical. The only effective way of controlling two units in parallel is with a single temperature controller. For further information, please contact Trane Applications.

# Application Considerations

10, 15 Ton

Figure AC-1 — Recommended Piping Components For Typical Evaporator Installation

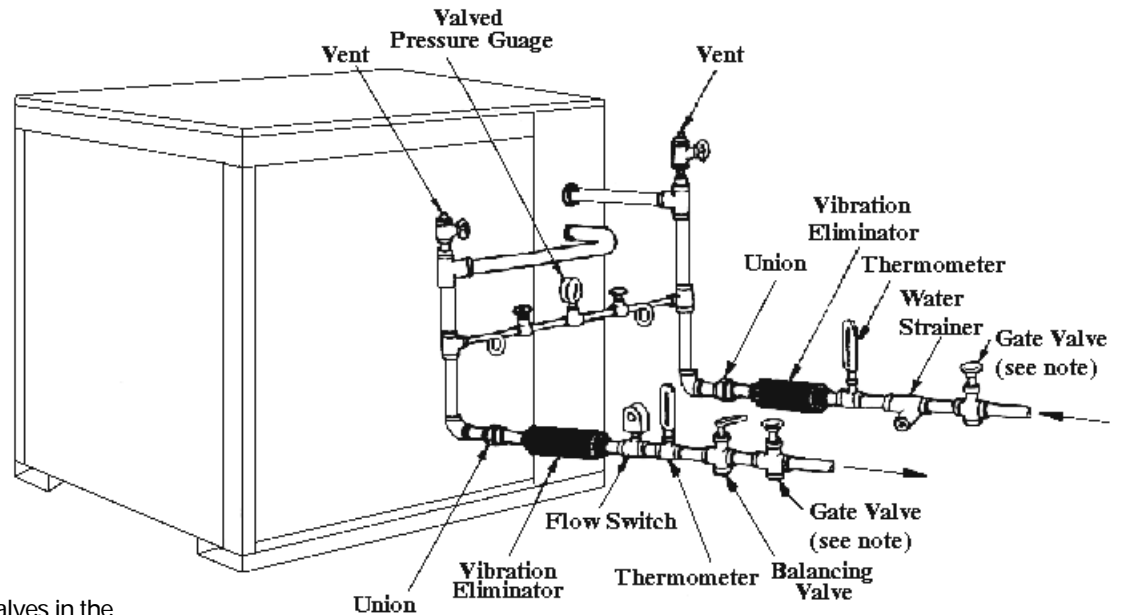

Note: Provide shutoff valves in the evaporator inlet and outlet to facilitate water temperature sensor removal.

20-60 Ton

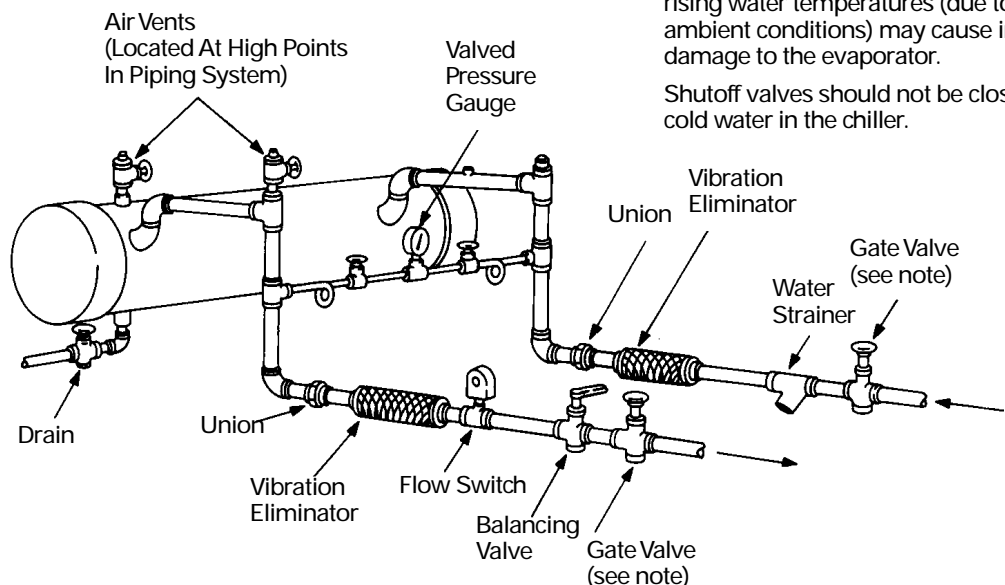

Note: High pressures resulting from rising water temperatures (due to ambient conditions) may cause internal damage to the evaporator.

Shutoff valves should not be closed with cold water in the chiller.

Note: Be certain to provide shutoff (gate) valves in the evaporator inlet and outlet piping to facilitate water temperature sensor removal.



# Selection Procedure

The chiller capacity tables presented in the "Performance Data" section cover the most frequently encountered leaving water temperatures. The tables reflect a 10°F temperature drop through the evaporator. For temperature drops other than 10°F, fouling factors other than 0.0001 (in accordance with ARI Standard 550/590-98) and for units operating at altitudes that are significantly greater than sea level, refer to the "Performance Adjustment Factors" section and apply the appropriate adjustment factors. For chilled brine selections, refer to the "Performance Adjustment Factors" section for ethylene glycol adjustment factors.

To select a Trane air-cooled chiller, the following information is required:

- 1 Design system load (in tons of refrigeration).
- 2 Design leaving chilled water temperature.
- 3 Design chilled water temperature drop.
- 4 Design ambient temperature.
- 5 Evaporator fouling factor.

Evaporator chilled water flow rate can be determined by using the following formula:

$$\text{GPM} = \frac{\text{Tons} \times 24}{\text{Temperature Drop (Degrees F)}}$$

NOTE: Flow rate must fall within the limits specified in the "General Data" section of this catalog.

## SELECTION EXAMPLE

Given:

- Required System Load = 53 tons
- Leaving Chilled Water Temperature (LCWT) = 45°F
- Chilled Water Temperature Drop = 10°F
- Design Ambient Temperature = 95°F
- Evaporator Fouling Factor = 0.0001

1 To calculate the required chilled waterflow rate we use the formula:

$$\text{GPM} = \frac{\text{Tons} \times 24}{\Delta T}$$

From the 60 ton unit table in the "Performance Data" section of this catalog, a CGAF-C60 at the given conditions will produce 57.3 tons with a system power input of 70.2 kw and a unit EER of 9.8

$$\text{GPM} = \frac{56.8 \text{ Tons} \times 24}{10^\circ\text{F}} = 137.5$$

2 To determine the evaporator water pressure drop we use the flow rate (gpm) and the evaporator water pressure drop curves found in the "Performance Adjustment Factors" section of this catalog. Entering the curve at 137.5 gpm, the pressure drop for a nominal 60 ton evaporator is 16.5 feet.

3 For selection of chilled brine units or applications where the altitude is significantly greater than sea level or the temperature drop is different than 10°F, the performance adjustment factors should be applied at this point.

For example:

Corrected Capacity = Capacity (unadjusted) x Appropriate Adjustment Factor

Corrected Flow Rate = Flow Rate (unadjusted) x Appropriate Adjustment Factor

Corrected KW Input = KW Input (unadjusted) x Appropriate Adjustment Factor

4 Verify that the selection is within design guidelines. The final unit selection is:

- Quantity (1) CGAF-C60
- Cooling Capacity = 57.3 Tons
- Entering/Leaving Chilled Water Temperatures = 55/45°F
- Chilled Waterflow Rate (GPM) = 137.5
- Evaporator Water Pressure Drop = 16.5 ft.

System Power Input = 70.2 KW

Unit EER = 9.8

## MINIMUM LEAVING CHILLED WATER TEMPERATURE SETPOINTS

The minimum leaving chilled water temperature setpoint for water is listed in the following table:

**Table SP-1 — Minimum Leaving Chilled Water Temperature Setpoints for Water<sup>1</sup>**

Evaporator Temperature Difference (Degrees F)	Minimum Leaving Chilled Water Temperature Setpoint (°F)	
	CGAF-C20,C25,C30	CGAF-C40,C50,C60
6	40	39
8	41	39
10	42	40
12	43	40
14	44	41
16	45	41
18	46	42

<sup>1</sup>These are for units without HGBP, for units with HGBP, add 2°F to each minimum temperature in the table.

For those applications requiring lower setpoints, a glycol solution must be used. The minimum leaving chilled water setpoint for a glycol solution can be calculated using the following equation:

$$\text{LCWS (Minimum) (Evap)} = \text{GFT} + 5 + \Delta T$$

# of stages of capacity.

LCWS = Leaving Chilled Water Setpoint (F)

GFT = Glycol Freezing Temperature (F)

ΔT = Delta T (the difference between the temperature of the water entering and leaving the evaporator)

Solution freezing point temperatures can be found in the Performance Data section and the number of stages of capacity in the General Data section. For selection assistance, refer to the CGA Chiller Selection program.



# Model Number Description

## 10, 15 Tons

**CGA** **120** **B** **3** **00** **B** **A**  
123 456 7 8 9,10 11 12

### DIGIT 1,2,3 — Unit Type

CGA = Air-Cooled Cold Generator™

### DIGITS 4,5,6 — Nominal Capacity(MBh)

100 = 8 Tons (50 Hz Model only)  
120 = 10 Tons (60 Hz Model only)  
150 = 12.5 Tons (50 Hz Model Only)  
180 = 15 Tons (60 Hz Model Only)

### DIGIT 7 — Major Design Change

(Number of Refrigerant Circuits/Number of Compressors)  
B = 2 Refrigerant Circuits/2 Compressors

### DIGIT 8 — Voltage

1 = 208-230/60/1  
(Available — CGA120 Only)  
3 = 208-230/60/3  
4 = 460/60/3  
W = 575/60/3  
D = 380-415/50/3

### DIGIT 9 — Factory Installed Options

0 = No Options  
H = Hot Gas Bypass  
C = Black Epoxy Coil Standard Deviation  
K = Hot Gas Bypass & Black Epoxy Coil  
S = Special

### DIGIT 10 — Leaving Solution Setpoint

0 = Standard Expansion Valve  
40-60°F Leaving Water  
(CGA100 & CGA120 models)  
20-60°F Leaving Solution  
(CGA150 & CGA180 Models)  
V = Nonstandard Expansion Valve  
20-39°F Leaving Solution  
(CGA100 & CGA120 models)

### DIGIT 11 — Minor Design Change

A = First, B = Second, etc.

### DIGIT 12 — Service Digit

## 20-60 Tons

**CG** **A** **F** **C40** **4** **A** **A** **A** **1** **A** **A** **A** **A** **A** **0** **0** **0** **0** **0** **0** **0**  
12 3 4 567 8 9 10 11 12 13 14 15 16 17 18 19 20 21 22 23 24 25

### DIGIT 1,2 — Unit Model

CG = IntelliPak™ Air-Cooled Chiller

### DIGIT 3 — Unit Type

A = Air-Cooled Condensing

### DIGIT 4 — Development Sequence

F = Sixth

### DIGIT 5,6,7 — Nominal Capacity

C20 = 20 Tons  
C25 = 25 Tons  
C30 = 30 Tons  
C40 = 40 Tons  
C50 = 50 Tons  
C60 = 60 Tons

### DIGIT 8 — Voltage & Start Characteristics

E = 200/60/3 XL  
F = 230/60/3 XL  
4 = 460/60/3 XL  
5 = 575/60/3 XL  
9 = 380/50/3 XL  
D = 415/50/3 XL  
S = Special

### DIGIT 9 — Factory Input

A = Standard

### DIGIT 10 — Design Sequence

A = First  
B = Second  
Etc...

### DIGIT 11 — Leaving Solution Setpoint

A = 40-50 Deg. F w/o Ice Machine  
B = 30-39 Deg. F w/o Ice Machine  
D = 51-65 Deg. F w/o Ice Machine  
E = 20-29 Deg. F w/o Ice Machine  
1 = 40-50 Deg. F with Ice Machine  
2 = 30-39 Deg. F with Ice Machine  
3 = 51-65 Deg. F with Ice Machine  
4 = 20-29 Deg. F with Ice Machine  
S = Special

### DIGIT 12 — Agency Approval

1 = UL/CSA  
0 = None

### DIGITS 13-25 — Miscellaneous

A = Trane Communication Interface (TCI) Module  
B = No Unit Heat Tape (50 Hz Only)  
C = Compressor Current Sensing (CSM)  
D = Unit Mounted Disconnect Switch Nonfused  
E = Unit Isolators Neoprene  
F = Unit Isolators Spring  
G = Superheat/Sub-Cooling  
H = Hot Gas Bypass

J = Generic B A S Module  
(0-5 v Input, Binary Output)  
M = Remote Human Interface  
N = Generic B A S Module  
(0-10 v Analog)  
P = Remote Setpoint Potentiometer  
Q = Zone Sensor — Chilled Solution Reset  
T = Flow Switch  
V = Copper Fin Condenser Coils  
W = Electronic Low Ambient Damper(s)  
Y = Inter-Processor Communication Bridge (IPCB)  
9 = Packed Stock Unit

The following items can be ordered for separate shipment —

- Unit Isolators - Neoprene\*
- Unit Isolators - Spring\*
- Flow Switch
- Electronic Low Ambient Damper(s)
- Trane Communication Interface Module (TCI)
- Generic B A S Module (GBAS)
- (0-5 volt Analog Input/Binary Output)
- Generic B A S Module (GBAS)
- (0-10 volt Analog Input/Output)
- Remote Human Interface
- Remote Setpoint Potentiometer
- Zone Sensor (Chilled Solution Reset)
- Inter-Processor Communication Bridge (IPCB)

\*Unit size must be specified when ordering this item.

1. The service digit for each model number contains 25 digits; all 25 digits must be referenced.



# General Data

**Table GD-1 — General Data — 10-60 Ton Units**

	10Ton	15Ton	20Ton	25Ton	30Ton	40Ton	50Ton	60Ton
<b>Model Number</b>	CGA120	CGA180	CGAF-C20	CGAF-C25	CGAF-C30	CGAF-C40	CGAF-C50	CGAF-C60
<b>Compressor Data</b>								
Model	Scroll	Scroll	Scroll	Scroll	Scroll	Scroll	Scroll	Scroll
Quantity	2	2	2	1/1	2	4	2/2	4
Nominal Tons per Compressor	5	7.5	10	10/15	15	10	10/15	15
<b>Evaporator</b>								
Nominal Size (Tons)	10	15	20	25	30	40	50	60
Water Storage Capacity (Gallons) <sup>2</sup>	1.4	1.5	11.7	10.7	16.3	13.8	21.0	37.8
Min. Flow Rate (GPM)	12.0	18.0	24	30	36	48	60	72
Max. Flow Rate (GPM)	36.0	54.0	72	90	108	144	180	216
Max EWT At Start-Up — Deg F <sup>3</sup>	100	100	108	108	108	108	108	108
<b>Condenser</b>								
Nominal Size (Tons)	10	15	20	25	30	40	50	60
Number of Coils	1	2	1	2	2	2	2	2
Coil Size (ea., Inches) <sup>4</sup>	28 x 108	28 x 83	61 x 71	45 x 71/35 x 71	56 x 70	56 x 70	57 x 96	57 x 96
Number of Rows	2	2	3	3	3	3	3	4
Subcooler Size (ea., Inches)	4 x 108	4 x 83	10 x 71	14 x 71	9 x 70	9 x 70	9 x 96	9 x 96
<b>Condenser Fans</b>								
Quantity	1	2	2	3	4	4	6	6
Diameter (Inches)	28	26	26	26	26	26	26	26
CFM (Total)	8,120	11,600	15,000	21,650	29,200	29,200	42,300	40,700
Nominal RPM	1100	1100	1140	1140	1140	1140	1140	1140
Tip Speed (Ft/Min)	8060	7490	7750	7750	7750	7750	7750	7750
Motor HP (ea.)	1.0	1/2	1.0	1.0	1.0	1.0	1.0	1.0
Drive Type	Direct	Direct	Direct	Direct	Direct	Direct	Direct	Direct
<b>Minimum Outdoor Air Temperature Permissible</b>								
<b>For Mechanical Cooling<sup>1</sup></b>								
Standard Ambient Control Unit (°F)	50	50	30	30	30	30	30	30
Standard Ambient w/Hot Gas Bypass (°F)	60	60	40	40	40	40	40	40
Low Ambient Option (°F)	0	0	0	0	0	0	0	0
Low Ambient Control w/Hot Gas Bypass(°F)	15	15	10	10	10	10	10	10
<b>General Unit</b>								
Unload Steps	100-50	100-50	100-50	100-60-40	100-50	100-75-50-25	100-80-60-30	100-75-50-25
No. of Independent Refrig. Circuits	2	2	1	1	1	2	2	2
Refrigerant Charge (lbs. R22/Circuit)	8.25	11.5	40.5	54.0	72.0	38.0	47.0	67.0
Oil Charge (Pints/Circuit)	4.1	7.5	8.0	8.0/14.0	14.0	8.0	8.0/14.0	14.0

\*Unloading steps depend upon which compressor is lead compressor.

Notes:

(1) Minimum start-up ambient based on unit at minimum step of unloading and a 5 mph wind across the condenser.

(2) Includes piping internal to chiller.

(3) At 95°F ambient.

(4) Does not include subcooling portion of coil.



# Performance Adjustment Factors

**Table PAF-3— Performance Adjustment Factors (10 & 15 Ton Units Only)**

Fouling Factor	Water $\Delta T$	Chilled									Altitude		
		Sea Level			2,000 Feet			4,000 Feet			6,000 Feet		
		CAP	GPM	KW	CAP	GPM	KW	CAP	GPM	KW	CAP	GPM	KW
0.00025	6	1.00	1.66	1.00	0.98	1.63	1.01	0.95	1.59	1.02	0.93	1.54	1.05
	8	1.00	1.25	1.00	0.98	1.22	1.01	0.96	1.19	1.02	0.93	1.16	1.05
	10	1.00	1.00	1.00	0.98	0.98	1.01	0.95	0.95	1.02	0.92	0.92	1.04
	12	1.00	0.83	1.00	0.98	0.81	1.01	0.95	0.79	1.02	0.92	0.77	1.04
	14	0.99	0.71	1.00	0.97	0.59	1.01	0.95	0.68	1.02	0.92	0.66	1.04
0.001	6	0.96	1.60	0.98	0.94	1.57	0.99	0.92	1.53	1.00	0.90	1.49	1.01
	8	0.96	1.20	0.98	0.94	1.18	0.99	0.92	1.15	1.00	0.90	1.12	1.01
	10	0.96	0.96	0.98	0.94	0.94	0.99	0.92	0.92	1.00	0.89	0.89	1.01
	12	0.96	0.80	0.98	0.94	0.79	0.99	0.92	0.77	1.00	0.89	0.74	1.01
	14	0.96	0.68	0.98	0.94	0.67	0.99	0.92	0.65	1.00	0.89	0.66	1.01
0.002	8	0.93	1.15	0.95	0.91	1.13	0.96	0.88	1.10	0.98	0.86	1.07	0.99
	10	0.90	0.90	0.94	0.89	0.88	0.95	0.87	0.87	0.96	0.85	0.84	0.98
	12	0.90	0.75	0.94	0.88	0.73	0.95	0.86	0.72	0.95	0.84	0.70	0.98
	14	0.90	0.64	0.94	0.87	0.63	0.95	0.86	0.82	0.95	0.84	0.60	0.98

\*Standard chilled water D is 8-12 for CGA120-180.  
Standard chilled water D is 6-16 for CGAF 20-60.

**Table PAF-4 — Performance Adjustment Factors (20-60 Ton Units Only)**

Fouling Factor	Water $\Delta T$	Chilled									Altitude		
		Sea Level			2,000 Feet			4,000 Feet			6,000 Feet		
		CAP	GPM	KW	CAP	GPM	KW	CAP	GPM	KW	CAP	GPM	KW
0.00025	6	0.987	1.650	0.993	0.967	1.640	1.003	0.952	1.620	1.019	0.932	1.570	1.029
	8	0.993	1.250	0.997	0.973	1.240	1.007	0.956	1.220	1.025	0.935	1.190	1.035
	10	1.000	1.000	1.000	0.980	0.990	1.010	0.960	0.970	1.030	0.940	0.940	1.040
	12	1.007	0.820	1.003	0.987	0.810	1.013	0.966	0.800	1.035	0.945	0.780	1.045
	14	1.013	0.710	1.007	0.993	0.700	1.017	0.972	0.680	1.038	0.952	0.660	1.048
0.001	6	0.957	1.615	0.979	0.953	1.600	0.989	0.931	1.570	0.990	0.914	1.540	1.002
	8	0.964	1.215	0.982	0.959	1.210	0.992	0.937	1.180	0.994	0.920	1.170	1.006
	10	0.970	0.965	0.985	0.964	0.960	0.995	0.943	0.940	0.998	0.926	0.920	1.009
	12	0.976	0.785	0.989	0.966	0.790	0.998	0.945	0.770	1.007	0.926	0.760	1.018
	14	0.982	0.675	0.993	0.968	0.670	1.001	0.947	0.650	1.016	0.927	0.640	1.027
0.002	6	0.916	1.565	0.951	0.913	1.550	0.969	0.896	1.490	0.975	0.871	1.450	0.984
	8	0.923	1.245	0.958	0.919	1.170	0.972	0.898	1.110	0.979	0.874	1.080	0.987
	10	0.930	0.925	0.965	0.925	0.920	0.975	0.900	0.890	0.982	0.877	0.880	0.989
	12	0.934	0.810	0.969	0.927	0.750	0.978	0.908	0.730	0.986	0.885	0.720	0.993
	14	0.938	0.695	0.973	0.929	0.640	0.981	0.916	0.620	0.989	0.894	0.610	0.997
16	0.948	0.580	0.976	0.931	0.580	0.983	0.924	0.580	0.993	0.902	0.570	1.001	



# Performance Adjustment Factors

Chart PAF-1 — Evaporator Water Pressure Drop 10 and 15 Ton Air-Cooled Chillers

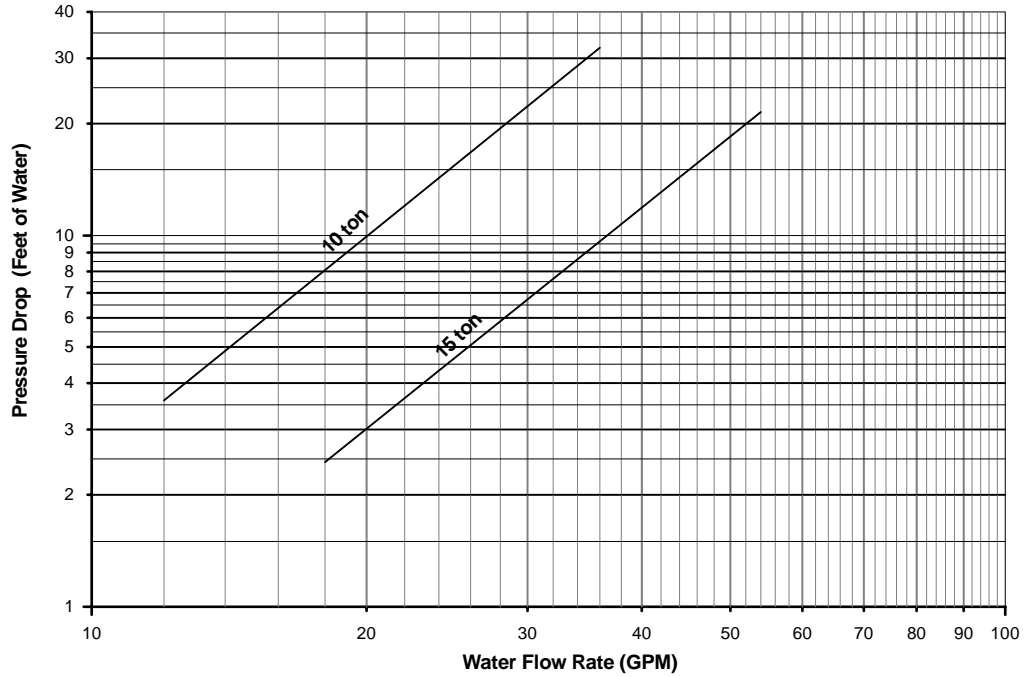
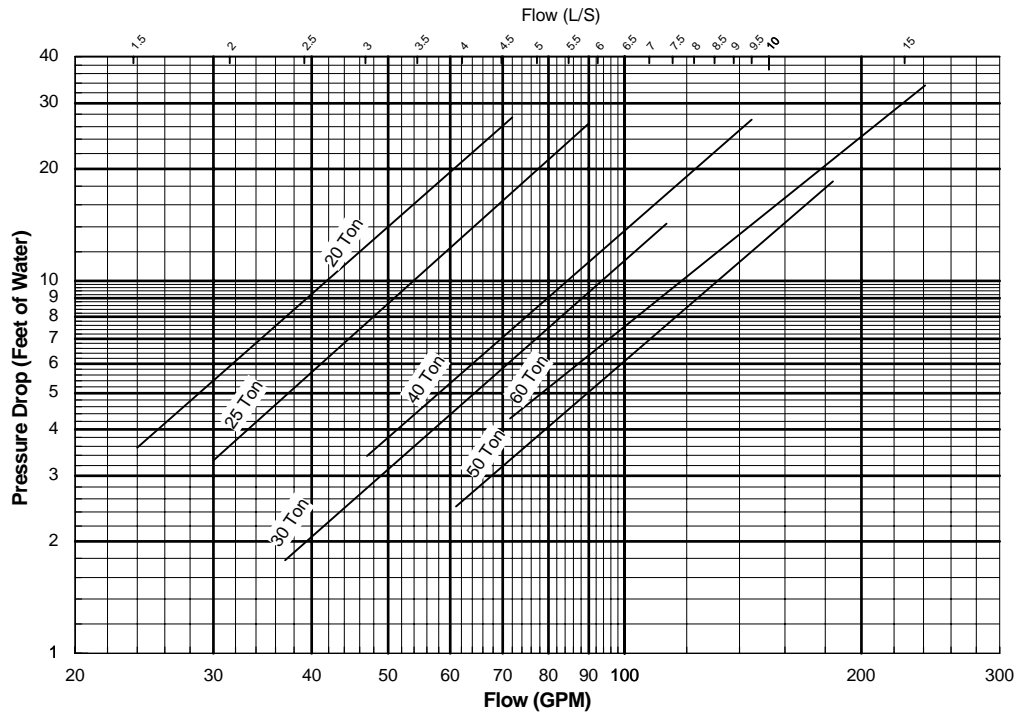

Chart PAF-2 — Evaporator Water Pressure Drop 20-60 Ton Air-Cooled Chillers



# Performance Adjustment Factors

Chart PAF-3— Ethylene Glycol Performance Factors

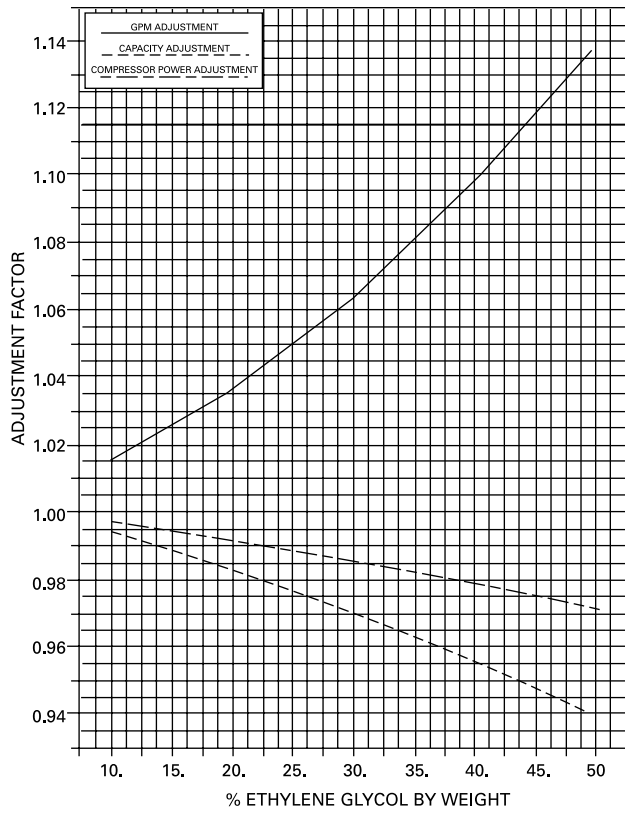
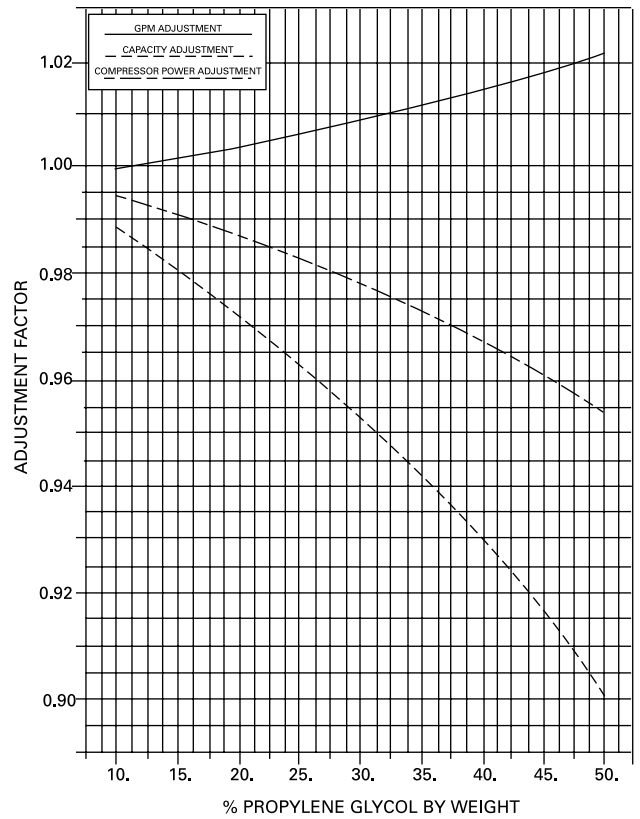

Chart PAF-4— Propylene Glycol Performance Factors





# Performance Adjustment Factors

Chart PAF-5— Ethylene Glycol and Propylene Glycol Performance Factors

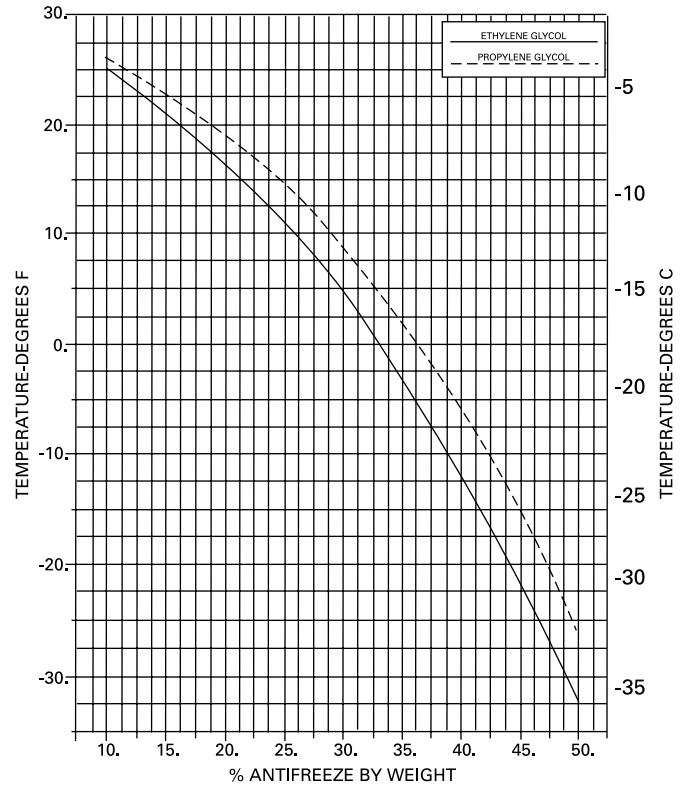



# Performance Data — 60 HZ

## (10-15 Ton) Full Load

**Table PD-1 — 10 Ton — CGA 120**

LWT (Deg F)	Percent Glycol	Entering Condenser Air Temperature (Degree F)														
		75.0			85.0			95.0			105.0			115.0		
		Capacity (Tons)	System KW	EER	Capacity (Tons)	System KW	EER	Capacity (Tons)	System KW	EER	Capacity (Tons)	System KW	EER	Capacity (Tons)	System KW	EER
20	28	6.1	7.3	10.0	5.6	8.2	8.2	5.1	8.5	7.2	4.8	8.7	6.5	N/A	N/A	N/A
25	24	6.8	7.7	10.5	6.3	8.5	8.9	5.8	8.9	7.9	5.3	9.3	6.9	5.0	10.4	5.8
30	19	7.6	8.1	11.2	7.0	8.7	9.6	6.5	9.1	8.6	6.0	9.8	7.4	5.6	11.0	6.1
35	14	8.4	8.4	12.0	7.8	9.0	10.4	7.2	9.4	9.2	6.7	10.2	7.9	6.3	11.6	6.5
40	0	9.2	8.6	12.8	8.7	9.1	11.5	8.1	9.5	10.2	7.5	10.8	8.4	7.0	12.2	6.9
42	0	9.5	8.7	13.0	9.0	9.2	11.8	8.4	9.6	10.5	7.8	11.0	8.6	7.3	12.4	7.1
44	0	9.8	8.8	13.3	9.3	9.4	11.9	8.7	9.7	10.8	8.0	11.2	8.6	7.5	12.7	7.1
45	0	10.0	8.9	13.4	9.5	9.4	12.2	8.8	9.8	10.8	8.2	11.3	8.8	7.7	12.8	7.2
46	0	10.2	8.9	13.7	9.6	9.5	12.2	8.9	9.9	10.8	8.3	11.3	8.8	7.8	12.9	7.2
48	0	10.5	9.0	14.0	9.9	9.6	12.3	9.2	10.0	11.1	8.6	11.5	9.0	8.0	13.0	7.4
50	0	10.8	9.1	14.2	10.2	9.7	12.6	9.5	10.1	11.3	8.9	11.7	9.1	8.3	13.2	7.5
55	0	11.6	9.4	14.8	11.0	10.0	13.2	10.3	10.6	11.6	9.6	12.1	9.5	9.0	13.9	7.8
60	0	12.4	9.7	15.4	11.8	10.4	13.6	11.0	11.0	12.0	10.3	12.6	9.8	9.7	14.5	8.0

**Table PD-2 — 15 Ton — CGA 180**

LWT (Deg F)	Percent Glycol	Entering Condenser Air Temperature (Degree F)														
		75.0			85.0			95.0			105.0			115.0		
		Capacity (Tons)	System KW	EER	Capacity (Tons)	System KW	EER	Capacity (Tons)	System KW	EER	Capacity (Tons)	System KW	EER	Capacity (Tons)	System KW	EER
20	28	9.3	11.9	9.4	8.5	12.2	8.4	7.7	12.3	7.5	7.0	12.4	6.8	N/A	N/A	N/A
25	24	10.5	12.6	10.0	9.7	13.0	9.0	8.8	13.3	8.0	8.0	13.5	7.1	7.2	16.2	5.3
30	19	11.8	13.4	10.6	10.9	13.9	9.4	10.0	14.2	8.5	9.1	14.6	7.5	8.3	17.5	5.7
35	14	13.1	14.2	11.1	12.2	14.7	10.0	11.2	15.1	8.9	10.3	15.6	7.9	9.4	19.0	5.9
40	0	14.8	14.9	11.9	13.7	15.6	10.5	12.7	16.1	9.4	11.7	16.7	8.4	10.7	20.4	6.3
42	0	15.3	15.1	12.2	14.3	15.9	10.7	13.2	16.5	9.6	12.1	17.1	8.5	11.1	21.0	6.3
44	0	15.8	15.4	12.3	14.8	16.1	11.0	13.7	16.9	9.7	12.6	17.5	8.6	11.6	21.4	6.5
45	0	16.1	15.5	12.5	15.0	16.3	11.1	13.9	17.1	9.7	12.8	17.7	8.6	11.8	21.7	6.5
46	0	16.4	15.7	12.5	15.3	16.5	11.1	14.2	17.2	9.9	13.1	17.9	8.8	12.0	21.9	6.6
48	0	16.9	16.0	12.7	15.8	16.8	11.3	14.7	17.6	10.0	13.5	18.2	8.9	12.5	22.5	6.7
50	0	17.5	16.2	13.0	16.3	17.1	11.4	15.2	17.9	10.2	14.0	18.7	9.0	12.9	22.8	6.8
55	0	18.8	16.9	13.3	17.7	17.9	11.9	16.5	18.8	10.5	15.2	19.7	9.3	14.1	24.2	7.0
60	0	20.3	17.6	13.8	19.0	18.7	12.2	17.8	19.8	10.8	16.5	20.6	9.6	15.4	25.6	7.2

**Notes:**

- 1 Based on the ethylene glycol concentration shown, a 10° delta T, a fouling factor of 0.0001 and sea level pressure.
- 2 Performance must be corrected for glycol concentrations other than those showing, delta T other than 10°, fouling factor and altitude.
- 3 Ethylene glycol is to be added and appropriate performance corrections are to be made for all leaving solution temperatures less than 40°F.
4. Use the following equation to calculate COP values at other than ARI conditions, COP = EER x .2928.



# Performance Data — 60 HZ

(20-25 Ton)  
Full Load

**Table PD-3 — 20Ton — CGAF-C20**

LWT (Deg F)	Percent Glycol	Entering Condenser Air Temperature (Degree F)														
		75.0			85.0			95.0			105.0			115.0		
		Capacity (Tons)	System KW	EER	Capacity (Tons)	System KW	EER	Capacity (Tons)	System KW	EER	Capacity (Tons)	System KW	EER	Capacity (Tons)	System KW	EER
20	28	11.5	15.8	8.8	10.9	17.4	7.6	10.3	19.2	6.4	9.6	21.4	5.4	8.8	23.9	4.4
25	24	13.0	16.2	9.7	12.4	17.8	8.3	11.6	19.7	7.1	10.9	21.9	6.0	10.1	24.4	4.9
30	19	14.6	16.6	10.6	13.9	18.3	9.1	13.1	20.2	7.8	12.2	22.4	6.5	11.4	24.9	5.5
35	14	16.2	17.0	11.4	15.4	18.7	9.9	14.6	20.7	8.4	13.7	23.0	7.1	12.7	25.5	6.0
40	0	18.0	17.5	12.4	17.2	19.3	10.7	16.2	21.3	9.2	15.3	23.6	7.8	14.2	26.1	6.5
42	0	18.7	17.7	12.7	17.8	19.5	11.0	16.9	21.5	9.4	15.9	23.8	8.0	14.8	26.4	6.7
44	0	19.4	17.9	13.0	18.5	19.6	11.3	17.5	21.7	9.7	16.4	24.0	8.2	15.4	26.6	6.9
45	0	19.7	18.0	13.2	18.8	19.7	11.4	17.8	21.8	9.8	16.7	24.1	8.3	15.6	26.7	7.0
46	0	20.1	18.1	13.3	19.1	19.8	11.6	18.1	21.9	9.9	17.0	24.2	8.4	15.9	26.8	7.1
48	0	20.8	18.2	13.7	19.8	20.1	11.8	18.7	22.1	10.2	17.6	24.5	8.7	16.5	27.1	7.3
50	0	21.5	18.4	14.0	20.5	20.3	12.1	19.4	22.3	10.4	18.3	24.7	8.9	17.1	27.3	7.5
55	0	23.3	18.9	14.8	22.2	20.8	12.8	21.1	22.9	11.0	19.8	25.3	9.4	18.6	27.9	8.0
60	0	25.2	19.5	15.5	24.0	21.4	13.5	22.8	23.5	11.6	21.5	25.9	9.9	20.1	28.6	8.4

**Table PD-4 — 25Ton — CGAF-C25**

LWT (Deg F)	Percent Glycol	Entering Condenser Air Temperature (Degree F)														
		75.0			85.0			95.0			105.0			115.0		
		Capacity (Tons)	System KW	EER	Capacity (Tons)	System KW	EER	Capacity (Tons)	System KW	EER	Capacity (Tons)	System KW	EER	Capacity (Tons)	System KW	EER
20	28	15.4	21.4	8.6	14.5	23.3	7.5	13.6	25.6	6.4	12.7	28.2	5.4	11.8	31.1	4.5
25	24	17.3	21.9	9.5	16.4	23.9	8.2	15.4	26.2	7.1	14.4	28.8	6.0	13.4	31.8	5.1
30	19	19.4	22.4	10.4	18.4	24.4	9.0	17.4	26.8	7.8	16.3	29.5	6.6	15.2	32.6	5.6
35	14	21.6	22.9	11.3	20.5	25.1	9.8	19.4	27.5	8.5	18.2	30.2	7.2	17.0	33.3	6.1
40	0	23.9	23.5	12.2	22.8	25.7	10.6	21.6	28.2	9.2	20.3	31.0	7.9	19.0	34.1	6.7
42	0	24.8	23.8	12.5	23.6	25.9	10.9	22.4	28.4	9.4	21.1	31.3	8.1	19.8	34.4	6.9
44	0	25.7	24.0	12.9	24.5	26.2	11.2	23.2	28.7	9.7	21.9	31.5	8.3	20.5	34.7	7.1
45	0	26.2	24.1	13.0	24.9	26.3	11.4	23.6	28.8	9.8	22.3	31.7	8.4	20.9	34.9	7.2
46	0	26.7	24.2	13.2	25.4	26.4	11.5	24.1	29.0	10.0	22.7	31.8	8.6	21.3	35.0	7.3
48	0	27.6	24.5	13.5	26.3	26.7	11.8	24.9	29.2	10.2	23.5	32.1	8.8	22.1	35.3	7.5
50	0	28.6	24.7	13.9	27.2	27.0	12.1	25.8	29.5	10.5	24.4	32.4	9.0	22.9	35.6	7.7
55	0	31.0	25.3	14.7	29.6	27.6	12.8	28.1	30.2	11.1	26.5	33.2	9.6	24.9	36.4	8.2
60	0	33.6	26.0	15.5	32.0	28.3	13.6	30.4	31.0	11.8	28.7	34.0	10.2	27.0	37.3	8.7

**Notes:**

1. Data based on 0.0001 fouling factor at sea level.
2. Interpolation between points is permissible.
3. Extrapolation beyond points is not permissible.
4. EER - Energy Efficiency Ratio (Btu/watt-hour). Power inputs include compressors, condenser fans and control power.
5. Ratings based on evaporator drop of 10°F.
6. Rated in accordance with ARI Standard 550/590-98.
7. Minimum recommended ethylene glycol percentage used for leaving water temperatures below 40°F.
8. Use the following equation to calculate COP values at other than ARI conditions, COP = EER x .2928.



# Performance Data — 60 HZ

## (30-40 Ton) Full Load

**Table PD-5— 30 Ton — CGAF-C30**

LWT (Deg F)	Percent Glycol	Entering Condenser Air Temperature (Degree F)														
		75.0			85.0			95.0			105.0			115.0		
		Capacity (Tons)	System KW	EER	Capacity (Tons)	System KW	EER	Capacity (Tons)	System KW	EER	Capacity (Tons)	System KW	EER	Capacity (Tons)	System KW	EER
20	28	18.2	25.8	8.5	17.2	28.2	7.3	16.2	30.9	6.3	15.1	34.0	5.3	14.0	37.5	4.5
25	24	20.6	26.4	9.4	19.5	28.8	8.1	18.3	31.5	7.0	17.2	34.7	5.9	15.9	38.3	5.0
30	19	23.1	26.9	10.3	21.9	29.4	8.9	20.6	32.2	7.7	19.3	35.5	6.5	18.0	39.1	5.5
35	14	25.7	27.5	11.2	24.4	30.0	9.8	23.0	32.9	8.4	21.7	36.2	7.2	20.2	39.9	6.1
40	0	28.5	28.1	12.2	27.1	30.7	10.6	25.7	33.6	9.2	24.2	37.0	7.8	22.7	40.8	6.7
42	0	29.6	28.3	12.5	28.2	30.9	10.9	26.7	33.9	9.4	25.1	37.3	8.1	23.6	41.1	6.9
44	0	30.7	28.5	12.9	29.2	31.2	11.2	27.7	34.2	9.7	26.1	37.6	8.3	24.5	41.4	7.1
45	0	31.2	28.6	13.1	29.7	31.3	11.4	28.2	34.3	9.8	26.6	37.8	8.4	24.9	41.6	7.2
46	0	31.8	28.8	13.3	30.3	31.4	11.6	28.7	34.5	10.0	27.1	37.9	8.6	25.4	41.7	7.3
48	0	32.9	29.0	13.6	31.3	31.7	11.9	29.7	34.7	10.3	28.0	38.2	8.8	26.3	42.1	7.5
50	0	34.0	29.2	14.0	32.4	31.9	12.2	30.8	35.0	10.5	29.0	38.5	9.0	27.3	42.4	7.7
55	0	37.0	29.9	14.9	35.2	32.6	13.0	33.4	35.8	11.2	31.6	39.3	9.7	29.7	43.2	8.2
60	0	40.0	30.5	15.7	38.1	33.3	13.7	36.2	36.5	11.9	34.3	40.1	10.3	32.2	44.1	8.8

**Table PD-6 — 40 Ton — CGAF-C40**

LWT (Deg F)	Percent Glycol	Entering Condenser Air Temperature (Degree F)														
		75.0			85.0			95.0			105.0			115.0		
		Capacity (Tons)	System KW	EER	Capacity (Tons)	System KW	EER	Capacity (Tons)	System KW	EER	Capacity (Tons)	System KW	EER	Capacity (Tons)	System KW	EER
20	28	22.5	30.7	8.8	21.4	33.9	7.6	20.1	37.6	6.4	18.7	41.8	5.4	17.2	46.6	4.4
25	24	25.4	31.5	9.7	24.1	34.7	8.3	22.7	38.5	7.1	21.2	42.8	6.0	19.6	47.7	4.9
30	19	28.5	32.3	10.6	27.1	35.6	9.1	25.5	39.4	7.8	23.9	43.8	6.5	22.2	48.7	5.5
35	14	31.7	33.2	11.5	30.1	36.5	9.9	28.5	40.4	8.5	26.7	44.8	7.1	24.8	49.8	6.0
40	0	35.3	34.1	12.4	33.5	37.5	10.7	31.7	41.5	9.2	29.8	46.0	7.8	27.8	51.0	6.5
42	0	36.6	34.4	12.7	34.8	37.9	11.0	32.9	41.9	9.4	30.9	46.4	8.0	28.9	51.5	6.7
44	0	37.9	34.8	13.1	36.0	38.3	11.3	34.1	42.3	9.7	32.1	46.8	8.2	29.9	51.9	6.9
45	0	38.5	35.0	13.2	36.7	38.4	11.4	34.7	42.5	9.8	32.7	47.0	8.3	30.5	52.1	7.0
46	0	39.2	35.1	13.4	37.3	38.6	11.6	35.3	42.7	9.9	33.2	47.2	8.4	31.0	52.3	7.1
48	0	40.6	35.5	13.7	38.6	39.0	11.9	36.6	43.1	10.2	34.4	47.7	8.7	32.1	52.8	7.3
50	0	42.0	35.9	14.0	39.9	39.4	12.2	37.8	43.5	10.4	35.6	48.1	8.9	33.3	53.2	7.5
55	0	45.5	36.8	14.8	43.3	40.4	12.9	41.0	44.6	11.0	38.7	49.2	9.4	36.2	54.4	8.0
60	0	49.2	37.8	15.6	46.8	41.5	13.5	44.4	45.7	11.6	41.8	50.4	9.9	39.1	55.7	8.4

**Notes:**

1. Data based on 0.0001 fouling factor at sea level.
2. Interpolation between points is permissible.
3. Extrapolation beyond points is not permissible.
4. EER - Energy Efficiency Ratio (Btu/watt-hour). Power inputs include compressors, water temperatures below 40°F.
5. Ratings based on evaporator drop of 10°F condenser fans and control power
6. Rated in accordance with ARI Standard 550/590-98.
7. Minimum recommended ethylene glycol percentage used for leaving water temperatures below 40°F.
8. Use the following equation to calculate COP values at other than ARI conditions. COP = EER x .2928.



# Performance Data — 60 HZ

(50-60Ton)  
Full Load

**Table PD-7— 50Ton — CGAF-C50**

LWT (Deg F)	Percent Glycol	Entering Condenser Air Temperature (Degree F)														
		75.0			85.0			95.0			105.0			115.0		
		Capacity (Tons)	System KW	EER	Capacity (Tons)	System KW	EER	Capacity (Tons)	System KW	EER	Capacity (Tons)	System KW	EER	Capacity (Tons)	System KW	EER
20	28	28.0	39.4	8.5	26.4	43.0	7.4	24.8	47.2	6.3	23.1	52.1	5.3	21.4	57.5	4.5
25	24	31.6	40.3	9.4	29.9	44.0	8.2	28.1	48.3	7.0	26.3	53.3	5.9	24.4	58.8	5.0
30	19	35.5	41.3	10.3	33.7	45.1	9.0	31.7	49.5	7.7	29.8	54.5	6.6	27.7	60.1	5.5
35	14	39.7	42.2	11.3	37.6	46.1	9.8	35.5	50.7	8.4	33.4	55.8	7.2	31.1	61.5	6.1
40	0	44.1	43.3	12.2	41.9	47.3	10.6	39.7	51.9	9.2	37.4	57.1	7.8	35.0	63.0	6.7
42	0	45.7	43.7	12.6	43.5	47.7	10.9	41.2	52.4	9.4	38.8	57.6	8.1	36.4	63.5	6.9
44	0	47.4	44.1	12.9	45.1	48.1	11.2	42.7	52.8	9.7	40.3	58.1	8.3	37.8	64.0	7.1
45	0	48.3	44.3	13.1	45.9	48.4	11.4	43.5	53.1	9.8	41.0	58.4	8.4	38.5	64.3	7.2
46	0	49.2	44.5	13.3	46.8	48.6	11.6	44.3	53.3	10.0	41.8	58.6	8.6	39.2	64.6	7.3
48	0	50.9	44.9	13.6	48.4	49.0	11.9	45.9	53.8	10.2	43.3	59.1	8.8	40.6	65.1	7.5
50	0	52.7	45.3	14.0	50.1	49.5	12.2	47.5	54.3	10.5	44.9	59.7	9.0	42.1	65.7	7.7
55	0	57.2	46.3	14.8	54.5	50.6	12.9	51.7	55.5	11.2	48.8	61.0	9.6	45.9	67.1	8.2
60	0	62.0	47.5	15.7	59.0	51.8	13.7	56.0	56.8	11.8	52.9	62.4	10.2	49.8	68.5	8.7

**Table PD-8— 60Ton — CGAF-C60**

LWT (Deg F)	Percent Glycol	Entering Condenser Air Temperature (Degree F)														
		75.0			85.0			95.0			105.0			115.0		
		Capacity (Tons)	System KW	EER	Capacity (Tons)	System KW	EER	Capacity (Tons)	System KW	EER	Capacity (Tons)	System KW	EER	Capacity (Tons)	System KW	EER
20	28	38.8	51.2	9.1	36.7	56.1	7.8	34.5	61.8	6.7	32.3	68.4	5.7	30.0	75.8	4.8
25	24	43.2	52.4	9.9	40.9	57.5	8.5	38.6	63.4	7.3	36.2	70.1	6.2	33.7	77.6	5.2
30	19	47.9	53.7	10.7	45.5	58.9	9.3	42.9	65.0	7.9	40.3	71.8	6.7	37.6	79.4	5.7
35	14	52.9	55.1	11.5	50.2	60.5	10.0	47.5	66.6	8.6	44.6	73.6	7.3	41.7	81.3	6.2
40	0	58.5	56.6	12.4	55.6	62.2	10.7	52.6	68.5	9.2	49.5	75.5	7.9	46.2	83.4	6.7
42	0	60.5	57.2	12.7	57.5	62.8	11.0	54.4	69.1	9.4	51.2	76.3	8.1	48.0	84.2	6.8
44	0	62.6	57.8	13.0	59.5	63.4	11.3	56.4	69.8	9.7	53.1	77.0	8.3	49.7	85.0	7.0
45	0	63.7	58.1	13.2	60.5	63.8	11.4	57.3	70.2	9.8	54.0	77.4	8.4	50.6	85.4	7.1
46	0	64.7	58.4	13.3	61.6	64.1	11.5	58.3	70.5	9.9	54.9	77.8	8.5	51.4	85.8	7.2
48	0	66.9	59.0	13.6	63.6	64.8	11.8	60.3	71.3	10.1	56.8	78.6	8.7	53.2	86.6	7.4
50	0	69.1	59.6	13.9	65.7	65.4	12.1	62.3	72.0	10.4	58.7	79.3	8.9	55.0	87.5	7.5
55	0	74.6	61.3	14.6	71.0	67.2	12.7	67.3	73.9	10.9	63.5	81.4	9.4	59.6	89.6	8.0
60	0	80.3	62.9	15.3	76.5	69.0	13.3	72.6	75.9	11.5	68.5	83.5	9.8	64.3	91.8	8.4

Notes:

1. Data based on 0.0001 fouling factor at sea level.
2. Interpolation between points is permissible.
3. Extrapolation beyond points is not permissible.
4. EER - Energy Efficiency Ratio (Btu/watt-hour). Power inputs include compressors, water temperatures below 40°F.
5. Ratings based on evaporator drop of 10°F condenser fans and control power
6. Rated in accordance with ARI Standard 550/590-98.
7. Minimum recommended ethylene glycol percentage used for leaving water temperatures below 40°F.
8. Use the following equation to calculate COP values at other than ARI conditions, COP = EER x .2928.



# Performance Data — 50 HZ

(20-30 Ton)  
Full Load

**Table PD-9— 20 Ton — CGAF-C20**

LWT (Deg F)	Percent Glycol	Entering Condenser Air Temperature (Degree F)														
		85.0			95.0			105.0			115.0			120.0		
		Capacity (Tons)	System KW	EER	Capacity (Tons)	System KW	EER	Capacity (Tons)	System KW	EER	Capacity (Tons)	System KW	EER	Capacity (Tons)	System KW	EER
40	0	14.4	15.2	11.4	13.7	17.0	9.7	12.8	19.0	8.1	12.0	21.3	6.7	11.5	22.5	6.1
42	0	15.0	15.3	11.7	14.2	17.1	9.9	13.3	19.2	8.4	12.4	21.5	7.0	12.0	22.7	6.3
44	0	15.6	15.5	12.1	14.7	17.3	10.2	13.8	19.3	8.6	12.9	21.6	7.2	12.4	22.9	6.5
45	0	15.8	15.5	12.2	15.0	17.3	10.4	14.1	19.4	8.7	13.2	21.7	7.3	12.7	23.0	6.6
46	0	16.1	15.6	12.4	15.3	17.4	10.5	14.4	19.5	8.8	13.4	21.8	7.4	12.9	23.1	6.7
48	0	16.7	15.7	12.7	15.8	17.6	10.8	14.9	19.7	9.1	13.9	22.0	7.6	13.4	23.3	6.9
50	0	17.3	15.9	13.1	16.4	17.7	11.1	15.4	19.8	9.3	14.4	22.2	7.8	13.9	23.4	7.1

**Table PD-10— 25 Ton — CGAF-C25**

LWT (Deg F)	Percent Glycol	Entering Condenser Air Temperature (Degree F)														
		85.0			95.0			105.0			115.0			120.0		
		Capacity (Tons)	System KW	EER	Capacity (Tons)	System KW	EER	Capacity (Tons)	System KW	EER	Capacity (Tons)	System KW	EER	Capacity (Tons)	System KW	EER
40	0	19.3	20.1	11.5	18.2	22.2	9.9	17.1	24.6	8.4	16.0	27.4	7.0	15.4	28.8	6.4
42	0	20.0	20.2	11.8	18.9	22.4	10.1	17.8	24.8	8.6	16.6	27.6	7.2	16.0	29.1	6.6
44	0	20.7	20.4	12.2	19.7	22.6	10.4	18.5	25.1	8.9	17.3	27.8	7.5	16.6	29.3	6.8
45	0	21.1	20.5	12.4	20.0	22.7	10.6	18.8	25.2	9.0	17.9	28.0	7.7	17.3	29.5	7.0
46	0	21.5	20.6	12.5	20.4	22.8	10.7	19.2	25.3	9.1	18.6	28.3	7.9	17.9	29.8	7.2
48	0	22.3	20.8	12.9	21.1	23.0	11.0	19.9	25.5	9.4	19.3	28.5	8.1	18.6	30.0	7.4
50	0	23.0	21.0	13.2	21.9	23.2	11.3	20.6	25.7	9.6	17.6	27.9	7.6	17.0	29.4	6.9

**Table PD-11 — 30 Ton — CGAF-C30**

LWT (Deg F)	Percent Glycol	Entering Condenser Air Temperature (Degree F)														
		85.0			95.0			105.0			115.0			120.0		
		Capacity (Tons)	System KW	EER	Capacity (Tons)	System KW	EER	Capacity (Tons)	System KW	EER	Capacity (Tons)	System KW	EER	Capacity (Tons)	System KW	EER
40	0	22.9	23.9	11.5	21.7	26.4	9.9	20.5	29.4	8.4	19.1	32.6	7.0	18.4	34.4	6.4
42	0	23.8	24.1	11.9	22.6	26.6	10.2	21.3	29.6	8.6	19.9	32.9	7.2	19.1	34.6	6.6
44	0	24.7	24.2	12.2	23.4	26.8	10.5	22.1	29.8	8.9	20.6	33.1	7.5	19.9	34.9	6.8
45	0	25.1	24.3	12.4	23.8	26.9	10.6	22.5	29.9	9.0	21.0	33.2	7.6	20.3	35.0	6.9
46	0	25.6	24.4	12.6	24.3	27.0	10.8	22.9	30.0	9.2	21.4	33.3	7.7	20.6	35.1	7.1
48	0	26.5	24.6	12.9	25.2	27.2	11.1	23.7	30.2	9.4	22.2	33.6	7.9	21.4	35.4	7.3
50	0	27.4	24.8	13.3	26.1	27.5	11.4	24.6	30.5	9.7	23.0	33.8	8.2	22.2	35.6	7.5

**Notes:**

1. Data based on 0.0001 fouling factor at sea level.
2. Interpolation between points is permissible.
3. Extrapolation beyond points is not permissible.
4. EER - Energy Efficiency Ratio (Btu/watt-hour). Power inputs include compressors, condenser fans and control power.
5. Ratings based on evaporator drop of 10° F.
6. Rated in accordance with ARI Standard 550/590-98
7. Minimum recommended ethylene glycol percentage used for leaving water temperatures below 40°.
8. Data obtained assuming 400 Volt Supply.
9. Use the following equation to calculate COP values at other than ARI conditions, COP = EER x .2928.



# Performance Data — 50 HZ

(40-60Ton)  
Full Load

**Table PD-12 — 40Ton — CGAF-C40**

		Entering Condenser Air Temperature (Degree F)														
		85.0			95.0			105.0			115.0			120.0		
LWT (Deg F)	Percent Glycol	Capacity (Tons)	System KW	EER	Capacity (Tons)	System KW	EER	Capacity (Tons)	System KW	EER	Capacity (Tons)	System KW	EER	Capacity (Tons)	System KW	EER
40	0	28.3	29.6	11.5	26.8	33.1	9.7	25.1	37.1	8.1	23.4	41.6	6.7	22.5	44.1	6.1
42	0	29.4	29.9	11.8	27.8	33.4	10.0	26.1	37.4	8.4	24.3	42.0	7.0	23.4	44.4	6.3
44	0	30.5	30.2	12.1	28.8	33.7	10.3	27.1	37.7	8.6	25.3	42.3	7.2	24.3	44.8	6.5
45	0	31.0	30.3	12.3	29.4	33.8	10.4	27.6	37.9	8.7	25.7	42.5	7.3	24.8	44.9	6.6
46	0	31.6	30.4	12.5	29.9	34.0	10.6	28.1	38.0	8.9	26.2	42.6	7.4	25.2	45.1	6.7
48	0	32.7	30.7	12.8	31.0	34.3	10.8	29.1	38.4	9.1	27.2	43.0	7.6	26.2	45.4	6.9
50	0	33.8	31.0	13.1	32.0	34.6	11.1	30.2	38.7	9.4	28.2	43.3	7.8	27.1	45.8	7.1

**Table PD-13 — 50Ton — CGAF-C50**

		Entering Condenser Air Temperature (Degree F)														
		85.0			95.0			105.0			115.0			120.0		
LWT (Deg F)	Percent Glycol	Capacity (Tons)	System KW	EER	Capacity (Tons)	System KW	EER	Capacity (Tons)	System KW	EER	Capacity (Tons)	System KW	EER	Capacity (Tons)	System KW	EER
40	0	35.5	36.9	11.5	33.6	40.9	9.9	31.6	45.4	8.4	29.4	50.5	7.0	28.3	53.2	6.4
42	0	36.8	37.2	11.9	34.9	41.2	10.2	32.8	45.8	8.6	30.6	50.8	7.2	29.5	53.6	6.6
44	0	38.2	37.5	12.2	36.2	41.5	10.5	34.1	46.1	8.9	31.8	51.2	7.5	30.6	54.0	6.8
45	0	38.9	37.7	12.4	36.9	41.7	10.6	34.7	46.3	9.0	32.4	51.4	7.6	31.2	54.2	6.9
46	0	39.6	37.8	12.6	37.6	41.9	10.8	35.4	46.5	9.1	33.0	51.6	7.7	31.8	54.4	7.0
48	0	41.0	38.2	12.9	38.9	42.2	11.1	36.7	46.9	9.4	34.3	52.0	7.9	33.0	54.8	7.2
50	0	42.5	38.5	13.2	40.3	42.6	11.4	38.0	47.3	9.6	35.5	52.4	8.1	34.2	55.2	7.4

**Table PD-14 — 60Ton — CGAF-C60**

		Entering Condenser Air Temperature (Degree F)														
		85.0			95.0			105.0			115.0			120.0		
LWT (Deg F)	Percent Glycol	Capacity (Tons)	System KW	EER	Capacity (Tons)	System KW	EER	Capacity (Tons)	System KW	EER	Capacity (Tons)	System KW	EER	Capacity (Tons)	System KW	EER
40	0	47.2	49.0	11.6	44.7	54.5	9.8	41.9	60.6	8.3	39.0	67.5	6.9	37.5	71.2	6.3
42	0	48.9	49.5	11.9	46.3	55.0	10.1	43.4	61.2	8.5	40.4	68.1	7.1	38.9	71.8	6.5
44	0	50.6	50.0	12.2	47.9	55.5	10.4	45.0	61.7	8.7	41.9	68.7	7.3	40.3	72.4	6.7
45	0	51.5	50.2	12.3	48.7	55.8	10.5	45.8	62.0	8.9	42.7	69.0	7.4	41.0	72.7	6.8
46	0	52.4	50.5	12.5	49.6	56.1	10.6	46.6	62.3	9.0	43.4	69.3	7.5	41.8	73.0	6.9
48	0	54.1	51.0	12.7	51.3	56.6	10.9	48.2	62.9	9.2	44.9	69.9	7.7	43.2	73.7	7.0
50	0	55.9	51.5	13.0	53.0	57.2	11.1	49.8	63.5	9.4	46.5	70.6	7.9	44.7	74.3	7.2

**Notes:**

1. Data based on 0.0001 fouling factor at sea level.
2. Interpolation between points is permissible.
3. Extrapolation beyond points is not permissible.
4. EER - Energy Efficiency Ratio (Btu/watt-hour). Power inputs include compressors, condenser fans and control power.
5. Ratings based on evaporator drop of 10°F.
6. Rated in accordance with ARI Standard 550/590-98
7. Minimum recommended ethylene glycol percentage used for leaving water temperatures below 40°.
8. Data obtained assuming 400 Volt Supply.
9. Use the following equation to calculate COP values at other than ARI conditions, COP = EER x .2928.

**Table PD-15 — Coefficient of Performance (COP) and Integrated Part Load Values (IPLV) at ARI Conditions**

Tons	Model Number	IPLV	COP
10	CGA 120	14.5	3.1
15	CGA 180	11.8	2.8
20	CGAF-C20	14.2	2.8
25	CGAF-C25	13.6	2.8
30	CGAF-C30	13.5	2.8
40	CGAF-C40	14.5	2.8
50	CGAF-C50	14.2	2.8
60	CGAF-C60	15.0	2.8

**Notes:**

1. Integrated Part Load Values are EERs in (Btu/watt-hour).



# Performance Data — 60 HZ

(10-60Ton)  
Part Load

**Table PD-16— Part Load Data, ARI Points (10-60Tons)**

Model		Entering Condenser Air Temperature (Degrees F)								
		95	86	84.2	83.6	77	76.4	74	72.2	
Tons	Number	100% Load	85% Load	82% Load	81% Load	70% Load	69% Load	65% Load	62% Load	
10	CGA 120	EER	10.8	-	-	-	-	-	-	-
		Capacity (Tons)	8.7	-	-	-	-	-	-	-
		KW Input	9.7	-	-	-	-	-	-	-
15	CGA 180	EER	9.7	-	-	-	-	-	-	-
		Capacity (Tons)	13.7	-	-	-	-	-	-	-
		KW Input	16.9	-	-	-	-	-	-	-
20	CGAF-C20	EER	9.7	-	-	-	-	-	-	-
		Capacity (Tons)	17.5	-	-	-	-	-	-	-
		KW Input	21.7	-	-	-	-	-	-	-
25	CGAF-C25	EER	9.7	-	-	-	13.4	-	-	-
		Capacity (Tons)	23.2	-	-	-	16.1	-	-	-
		KW Input	28.7	-	-	-	14.5	-	-	-
30	CGAF-C30	EER	9.7	-	-	-	-	-	-	-
		Capacity (Tons)	27.7	-	-	-	-	-	-	-
		KW Input	34.2	-	-	-	-	-	-	-
40	CGAF-C40	EER	9.7	-	-	11.8	-	-	-	-
		Capacity (Tons)	34.1	-	-	27.8	-	-	-	-
		KW Input	42.3	-	-	28.3	-	-	-	-
50	CGAF-C50	EER	9.7	11.3	-	-	13.3	-	-	-
		Capacity (Tons)	42.7	36.5	-	-	29.8	-	-	-
		KW Input	52.8	38.9	-	-	26.9	-	-	-
60	CGAF-C60	EER	9.7	-	11.9	-	-	-	-	15.2
		Capacity (Tons)	56.4	-	46.3	-	-	-	-	35
		KW Input	69.8	-	46.6	-	-	-	-	27.6

**Table PD-16 — Part Load Data, ARI Points (10-60Tons) Continued**

Model		Entering Condenser Air Temperature (Degrees F)						
		71.6	71.0	67.0	64.4	57.2	55	
Tons	Number	61% Load	60% Load	53%	49% Load	37% Load	32% Load	
10	CGA 120	EER	-	-	15.5	-	-	-
		Capacity (Tons)	-	-	4.6	-	-	-
		KW Input	-	-	3.5	-	-	-
15	CGA 180	EER	-	-	12.4	-	-	-
		Capacity (Tons)	-	-	7.2	-	-	-
		KW Input	-	-	6.9	-	-	-
20	CGAF-C20	EER	-	14.6	-	-	-	-
		Capacity (Tons)	-	10.4	-	-	-	-
		KW Input	-	8.6	-	-	-	-
25	CGAF-C25	EER	-	-	-	14.4	-	-
		Capacity (Tons)	-	-	-	11.3	-	-
		KW Input	-	-	-	9.4	-	-
30	CGAF-C30	EER	-	13.7	-	-	-	-
		Capacity (Tons)	-	16.6	-	-	-	-
		KW Input	-	14.5	-	-	-	-
40	CGAF-C40	EER	14.8	-	-	-	-	17.1
		Capacity (Tons)	20.7	-	-	-	-	10.8
		KW Input	16.8	-	-	-	-	7.6
50	CGAF-C50	EER	-	-	-	-	16.9	-
		Capacity (Tons)	-	-	-	-	15.7	-
		KW Input	-	-	-	-	11.2	-
60	CGAF-C60	EER	-	-	-	-	-	18.3
		Capacity (Tons)	-	-	-	-	-	18.2
		KW Input	-	-	-	-	-	11.9

**Notes:**

- Rated in accordance with ARI Standard 550/590-98
  - 44 Degrees leaving chilled water temperature
  - Constant Evaporator waterflow as determined at full load operation, 95 F ambient, and 10F evaporator temperature drop.
  - Entering ambient temperature based on 55F for loads below 33%
  - Entering ambient temperature based on 0.60(%load)+35 for loads above 33%
  - EER- Energy Efficiency Ratio ( Btu/Watt-hour). Power inputs include compressor, condenser fans and control power.



# Performance Data — 50 HZ

# (20-30 Ton) Part Load

**Table PD-17 — 20Ton — CGAF-C20**

Percent		Entering Condenser Air Temperature (Degrees F)					
Load		75	85	95	105	115	120
100	EER	14.1	12.1	10.2	8.6	7.2	6.5
	Capacity	16.3	15.6	14.7	13.8	12.9	12.4
	System KW	13.9	15.5	17.3	19.3	21.6	22.9
50	EER	15.2	13.2	11.4	9.7	8.2	7.5
	Capacity	8.5	8.1	7.7	7.3	6.8	6.6
	System KW	6.7	7.4	8.1	9.0	10.0	10.6

**Table PD-18 — 25Ton — CGAF-C25**

Percent		Entering Condenser Air Temperature (Degrees F)					
Load		75	85	95	105	115	120
100	EER	14.1	12.2	10.4	8.9	7.5	6.8
	Capacity	21.7	20.7	19.7	18.5	17.3	16.6
	System KW	18.5	20.4	22.6	25.1	27.8	29.3
60	EER	15.4	13.5	11.7	10.0	8.4	7.7
	Capacity	13.5	12.9	12.2	11.6	10.8	10.4
	System KW	10.5	11.5	12.6	13.9	15.4	16.2
40	EER	14.4	12.6	11.0	9.4	8.0	7.3
	Capacity	8.9	8.5	8.1	7.6	7.1	6.9
	System KW	7.4	8.1	8.8	9.7	10.8	11.3

**Table PD-19 — 30Ton — CGAF-C30**

Percent		Entering Condenser Air Temperature (Degrees F)					
Load		75	85	95	105	115	120
100	EER	14.1	12.2	10.5	8.9	7.5	6.8
	Capacity	25.9	24.7	23.4	22.1	20.6	19.9
	System KW	22.0	24.2	26.8	29.8	33.1	34.9
50	EER	13.4	11.8	10.3	8.8	7.5	6.9
	Capacity	13.4	12.8	12.2	11.5	10.8	10.4
	System KW	12.0	13.0	14.3	15.7	17.3	18.2

**Notes:**

1. Data based on 0.0001 fouling factor at sea level.
2. Interpolation between points is permissible.
3. Extrapolation beyond points is not permissible.
4. EER - Energy Efficiency Ratio (Btu/watt-hour). Power inputs include compressors, condenser fans and control power
5. Ratings based on evaporator drop of 10°F
6. Rated in accordance with ARI Standard 550/590-98.
7. Data obtained assuming 400 Volt supply.



# Performance Data — 50 HZ

# (40-60 Ton) Part Load

**Table PD-20 — 40 Ton — CGAF-C40**

Percent Load		Entering Condenser Air Temperature (Degrees F)					
		75	85	95	105	115	120
100	EER	14.2	12.1	10.3	8.6	7.2	6.5
	Capacity	32.0	30.5	28.8	27.1	25.3	24.3
	System KW	27.1	30.2	33.7	37.7	42.3	44.8
75	EER	14.6	12.5	10.7	9.0	7.5	6.8
	Capacity	24.4	23.2	22.0	20.7	19.3	18.6
	System KW	20.1	22.2	24.7	27.6	30.9	32.7
50	EER	15.3	13.3	11.5	9.8	8.2	7.5
	Capacity	16.9	16.1	15.3	14.4	13.5	13.0
	System KW	13.2	14.5	16.0	17.8	19.8	20.9
25	EER	14.1	12.3	10.5	8.9	7.5	6.9
	Capacity	8.2	7.9	7.5	7.1	6.6	6.4
	System KW	7.0	7.7	8.5	9.5	10.6	11.2

**Table PD-21— 50Ton — CGAF-C50**

Percent Load		Entering Condenser Air Temperature (Degrees F)					
		75	85	95	105	115	120
100	EER	14.0	12.2	10.5	8.9	7.5	6.8
	Capacity	39.7	38.2	36.2	34.1	31.8	30.6
	System KW	34.0	37.5	41.5	46.1	51.2	54.0
80	EER	14.4	12.5	10.8	9.1	7.7	7.0
	Capacity	32.5	31.0	29.4	27.7	25.8	24.9
	System KW	27.0	29.7	32.8	36.3	40.3	42.4
60	EER	14.9	13.1	11.3	9.7	8.2	7.5
	Capacity	25.0	23.9	22.7	21.4	20.0	19.3
	System KW	20.1	21.9	24.1	26.6	29.4	30.9
30	EER	14.2	12.2	10.5	8.9	7.4	6.8
	Capacity	12.0	11.4	10.8	10.2	9.5	9.1
	System KW	10.1	11.2	12.4	13.8	15.3	16.1

**Table PD-22— 60 Ton — CGAF-C60**

Percent Load		Entering Condenser Air Temperature (Degrees F)					
		75	85	95	105	115	120
100	EER	14.1	12.2	10.4	8.7	7.3	6.7
	Capacity	53.2	50.6	47.9	45.0	41.9	40.3
	System KW	45.1	50.0	55.5	61.7	68.7	72.4
75	EER	14.7	12.7	10.9	9.2	7.8	7.1
	Capacity	40.8	38.9	36.9	34.7	32.3	31.1
	System KW	33.2	36.7	40.6	45.1	50.0	52.7
50	EER	16.0	14.0	12.1	10.3	8.8	8.0
	Capacity	28.6	27.4	26.0	24.6	23.1	22.2
	System KW	21.4	23.4	25.8	28.5	31.6	33.2
25	EER	15.4	13.3	11.4	9.6	8.1	7.4
	Capacity	13.9	13.2	12.6	11.8	11.0	10.6
	System KW	10.8	12.0	13.3	14.7	16.4	17.3

**Notes:**

1. Data based on 0.0001 fouling factor at sea level.
2. Interpolation between points is permissible.
3. Extrapolation beyond points is not permissible.
4. EER - Energy Efficiency Ratio (Btu/watt-hour). Power inputs include compressors, condenser fans and control power
5. Ratings based on evaporator drop of 10°F
6. Rated in accordance with ARI Standard 550/590-98.
7. Data obtained assuming 400 Volt supply.

# Controls

## Stand-Alone Unit

Interface to stand-alone units is very simple; only a remote auto-stop or chilled water flow interlock signal for scheduling is required for unit operation. Signals from the chilled water pump contactor auxiliary or a flow switch are wired to the chilled waterflow interlock. Signals from a time clock or some other remote device are wired to the external auto-stop input. Unit controls do not provide an output to turn pumps on and off.

### Required Features

- 1  
External Auto/Stop (Standard)  
- or -
- 2  
Chilled Waterflow Interlock (Standard)

Figure C-1 — Stand-Alone Unit

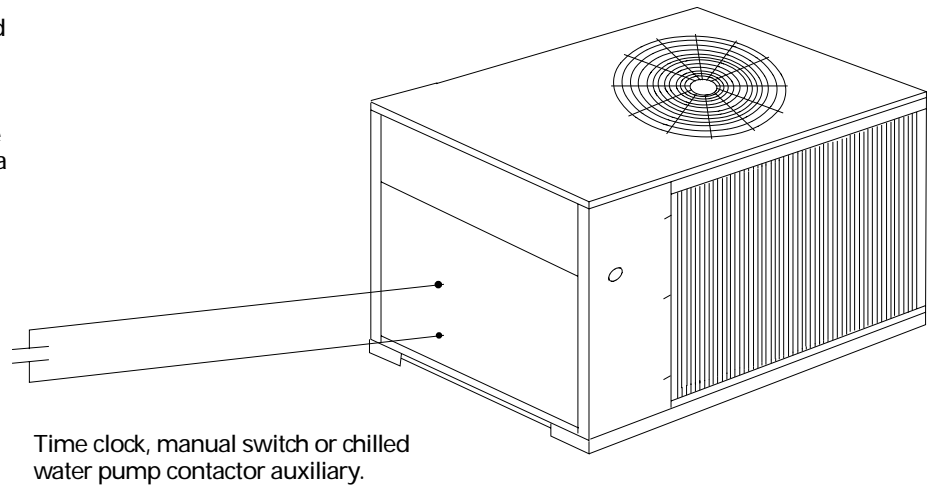

## Trane Integrated Comfort™ System Interface

A single twisted pair of wires tied directly between the CGA unit and a Tracer™ system provides control, monitoring and diagnostic capabilities. Control functions include auto/stop, compressor operation lockout for kw demand limiting. In addition, the Tracer system can provide sequencing control for two or three CGA units on the same chilled water loop. Pump sequencing control can be provided from the Tracer system also. Sequencing of two CGA's can be accomplished with the DDC Chiller Sequencer.

### Required Features

- 1  
Unit Temperature Controller (Standard)
- 2  
ICS Interface Panel

### External Trane Devices Required

- 1  
Tracer 100 System  
- or -  
Tracer L System

Figure C-2 — Tracer™ ICS System Interface Schematic

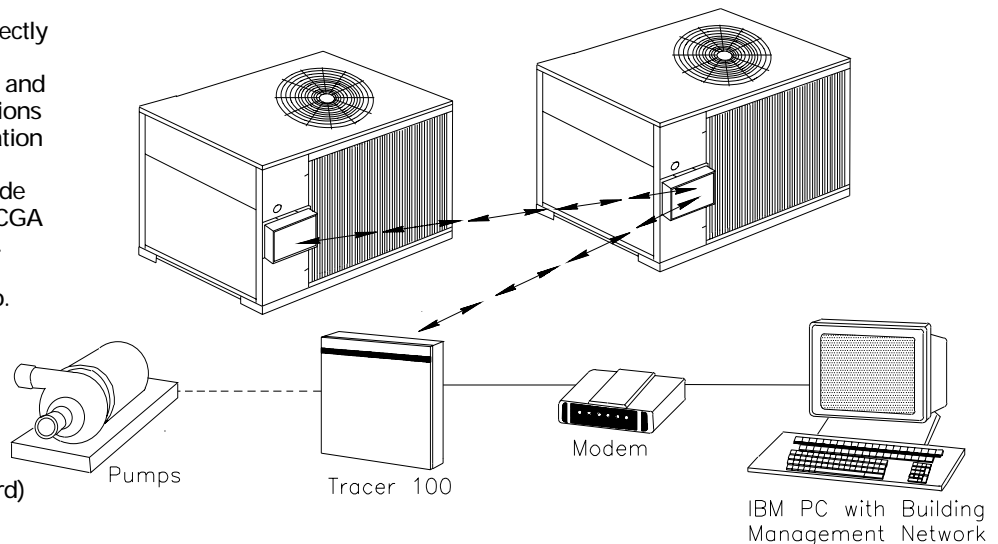

# Controls

(10, 15 Tons)

## ELECTRICAL CONTROL SYSTEM

The controls used on CGA 10 and 15-ton units are classified either as "safety" controls or "operational" controls. Brief descriptions of the specific safety and operating controls used in the CGA control scheme are provided in the following paragraphs.

Refer to the following control descriptions for control settings.

### UNIT SAFETY CONTROLS

#### Low Pressure Cutout (LPC01, LPC02)

Mounted below the unit control box are two low pressure cutouts that open and stop compressor operation if the operating pressure drops below  $38.5 \pm 1$  psig. The cutout automatically resets when the pressure reaches  $44.5 \pm 2$  psig. The LPCO is a SPDT device. If it opens at low ambient start-up, it will energize ODF relay, stopping the outdoor fan(s) while the compressor remains energized through the LAST (Low Ambient Start Timer).

#### High Pressure Cutout (HPC01, HPC02)

These units have high pressure cutouts that open and stop compressor operation if the discharge pressure reaches  $400 \pm 10$  psig. The cutout automatically resets when pressure drops to  $250 \pm 15$  psig.

#### Reset Relays (RRS, RR2)

If the unit is shut down by the low pressure cutout (or high pressure cutout), the reset relay locks out the compressor contactor (CCS, CC2). This prevents the system from recycling until the condition that caused the low (or high) pressure cutout to trip is determined and corrected.

**CAUTION:** To prevent unit damage, do not reset the control circuit until the cause of the safety lockout is identified and corrected.

To reset RR1 and RR2, open and reclose the unit disconnect switch.

#### Low Temperature Cutout (LTC)

The LTC is designed to disable the unit if the leaving water temperature falls too low. The LTC's remote sensing bulb is

mounted at the outlet end of the evaporator, where it monitors leaving water temperature.

During normal unit operation, if the low temperature cutout (LTC) senses a temperature falling to  $36^\circ\text{F} \pm 3.0^\circ\text{F}$ , the LTC will open to interrupt compressor operation. (Manual reset is required.)

#### Motor Overloads

These units have internal compressor and condenser fan motor overloads. These overloads protect the motors from overcurrent and overheating conditions and automatically reset as soon as they cool sufficiently.

### UNIT OPERATIONAL CONTROLS

#### Water Temperature Thermostat (WTT)

System operation for 10 and 15-ton CGA units is governed by a two-stage water temperature thermostat (WTT). The remote sensing bulb of this device is factory-installed in a bulb well located on the evaporator water inlet; here, it monitors the temperature of the water returning to the evaporator.

#### Low Ambient Start Timer (LAST)

When one of the two timers energizes, the low pressure control is bypassed for four minutes, this allows time for suction pressure to build sufficiently for the low pressure cutout contacts to close.

#### Hot Gas Bypass Timer, Solenoid (HGBT, HGBS)

The hot gas bypass option is factory-installed only, and is used in a chilled water system to keep the first stage compressor on-line during short no-load or light-load conditions. When Water Temperature Thermostat (WTT) first stage opens, 24-volt power is supplied to the Compressor Contactor (CC1) through Hot Gas Bypass Timer (HGBT) pins one and four. Power is also applied from WTT-B to HGBT coil (fixed 30-minute time delay pick-up) and to the Hot Gas Bypass Solenoid (HGBS) through HGBT pins eight and five. If first stage cooling remains satisfied for 30 minutes, HGBT will energize and shut down the compressor. If there is a call for cooling during HGBP mode, the unit will return to cooling mode.

The adjustable hot gas bypass valve is factory set at 70 psig.

Note: Hot gas bypass is available only on the lead compressor circuit.

#### Anti-Short Cycle Timers (ASCT1, ASCT2)

An anti-short cycle timer is provided in each compressor control circuit to protect the compressors from starting too frequently. This can occur as a result of just over 0%, or just over 50% of the unit capacity, or because of sudden power outages of short duration. Whenever the contacts of the water temperature thermostat (WTT) open – or when there is a momentary power outage – the anti-short cycle timer will lock out compressor operation for three minutes.

#### Delay Between Compressors (DBC)

The delay between compressors prevents both compressors from starting at the same time by delaying compressor number two for 30 seconds.

#### Definition of Abbreviations:

ASCT	-	Anti-Short Cycle Timer
CC	-	Compressor Contactor
CWFIR	-	Chilled Water Flow Interlock Relay
CWPS	-	Chilled Water Pump Starter
DBC	-	Time Delay Between Compressors
HGBT	-	Hot Gas Bypass Timer
HPCO	-	High Pressure Cutout
LAST	-	Low Ambient Start Timer
LPCO	-	Low Pressure Cutout
LTC	-	Low Temperature Cutout
ODF	-	Outdoor Fan
RR	-	Reset Relay
SPDT	-	Single Pole, Double Throw
WTT	-	Water Temperature Thermostat



# Controls

(10, 15 Tons)

## SEQUENCE OF UNIT OPERATION

Refer to the unit wiring schematic pasted to the inside of the control panel cover when reviewing the control sequence described below.

Refer to the legend on the previous page for an explanation of the abbreviations used in this sequence.

### 10-Ton Operation

With fused disconnect switch closed, power is supplied to the crankcase heaters and the 24-volt control circuit.

Starting the chilled water pump closes the CWPS auxiliary contacts and completes the flow switch.

When the water temperature rises above the WTT's setpoint, its first stage switch closes, allowing power to pass through CWPS auxiliary contacts, the flow switch, the LTC, the ASCT1, the RR1 contacts, the LPC01, and the HPC01 to energize the CC1 coil. This starts compressor number one and the outdoor fan.

If compressor number one can't satisfy the cooling demand, WTT's 2nd stage switch closes, allowing power to pass through the CC1 auxiliary contacts, the DBC, the ASCT2, the RR2 contacts, the LPC02, and the HPC02 to energize the CC2 coil which starts compressor number two.

### 15-Ton Operation

With fused disconnect switch closed, power is supplied to the crankcase heaters, and the 24-volt control circuit.

Starting the chilled water pump closes the CWPS auxiliary contacts and completes the flow switch, allowing power to pass through the LTC to energize the CWFIR.

When the water temperature rises above the WTT's setpoint, its first stage switch closes, allowing power to pass through the CWFIR contacts, the ASCT1, the RR1 contacts, the LPC01, and the HPC01 to energize the CC1 coil. This starts compressor number one and outdoor fan number one.

If compressor number one can't satisfy the cooling demand, WTT's second stage switch closes, allowing power to pass through the CWFIR contacts, the DBC, the ASCT2, the RR2 contacts, the LPC02, and the HPC02 to energize the CC2 coil. This starts compressor number two and outdoor fan number two.

## LOW AMBIENT OPERATION

### Field Installed Head Pressure Control Accessory

Standard units will operate in outdoor ambient temperatures down to the values shown in the "General Data" section of this catalog. This accessory will enable units to operate down to much lower temperature extremes (see "General Data" section of this catalog).

Head pressure control for CGA units is regulated by means of a field-installed head pressure accessory which varies condenser fan speed in relation to discharge pressure.

When discharge pressure is 270 psig or higher, the condenser fan runs at full speed. At pressures between 270 psig and 180 psig, the fan speed is adjusted (increased or decreased) in direct relation to the pressure, with minimum fan speed (10 percent of rated motor rpm) occurring when the pressure reaches 180 psig. At pressures below 180 psig, the fan will not run. When discharge pressure rises to 180 psig, the fan will start and run at the reduced speed. Fan speed will continue to increase, as the pressure increases, until full speed is reached at 270 psig.

# Controls

(20-60 Tons)

### Customized Control

With IntelliPak controls, Trane can customize controls around the chiller application and the specific components used in the CGAF.

For instance, the compressor protection system is specifically designed for the Trane 3-D™ Scroll compressor. A leaving chilled solution temperature control algorithm maintains accurate temperature control, for both comfort and process applications, minimizing the drift from setpoint.

The IntelliPak controls incorporate improved chiller start-up, load limiting, compressor anti-recycle timing and lead/lag functions into standard chiller operation. Interface with outside systems such as building automation controls is flexible and easy.

### Simple Interface with All Control Systems

The IntelliPak controls afford simple interface with Trane Tracer™ systems, providing broad control capabilities for Building Automation systems.

For control systems other than Trane, two generic building automation system interfaces are available and offer simplicity and flexibility in accessing unit functions.

### Safety Controls

A centralized microcomputer offers a higher level of machine protection. Since the safety controls are smarter, they limit compressor operation to avoid compressor or evaporator failures, thereby minimizing nuisance shutdown. For instance, the Unit Control Module (UCM) will provide condenser low

pressure control by staging condenser fans on or off in an effort to maintain the saturated condensing temperature within a fixed range. Overall, the safety controls help keep the cooling system on-line and operating safely.

### Monitoring and Diagnostics

Since the microcomputer provides all control functions, it can easily indicate such parameters as leaving chilled solution temperature and capacity staging. If a failure does occur, the diagnostic alarm will be displayed giving specific information about the failure. All of the monitoring and diagnostic information can be easily accessed at the Human Interface display, standard on every unit.

Figure C-3 — Human Interface Display

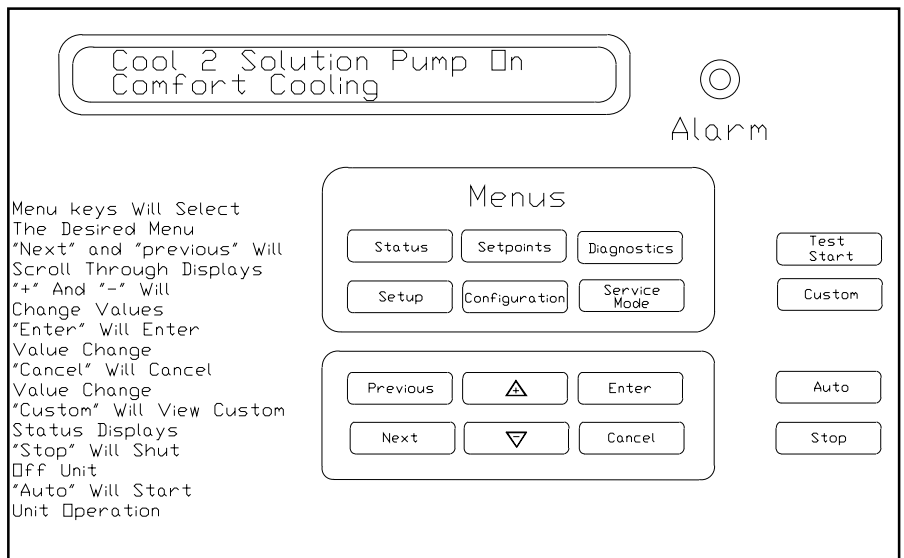



## (20-60 Tons Interface)

# Controls

## Standard Control Features

### Human Interface (HI) Panel

The Human Interface (HI) Panel provides a 2 line X 40 character clear English language liquid crystal display and a 16 button keypad for monitoring, setting, editing and controlling. The Human Interface Panel is mounted in the unit's main control panel and is accessible through a hatch built into the unit's control panel door.

The optional remote-mounted version of the Human Interface panel has all the functions of the unit-mounted HI, with the exception of the Service Mode. To use a Remote Human Interface (RHI), the unit must be equipped with an optional InterProcessor Communications Bridge (IPCB). The RHI can be located up to 5,000 feet from the unit. A single RHI can be used to monitor and control up to 4 chillers, each containing an IPCB.

### The Main Menu of the Human Interface panel:

**STATUS** – used to monitor all temperatures, pressures, setpoints, input and output status. The **CUSTOM KEY** will have four reports that can be user defined. The report screens consist of the data available in the main status menu.

**SETPOINTS** – used to edit all factory preset default setpoints and assign setpoint sources.

**DIAGNOSTICS** – used to review active and historical lists of diagnostic conditions. A total of 41 different diagnostics can be read at the Human Interface Panel. The last 20 diagnostics can be held in an active history buffer log at the Human Interface Panel.

**SETUP** – Control parameters, sensor selections, setpoint source selections, output definitions, and numerous other points can be edited from this menu. All points have factory preset values so unnecessary editing is kept to a minimum.

**CONFIGURATION** – Preset with the proper configuration for the unit as it ships from the factory, this information would be edited only if certain features were physically added or deleted from the unit. For example, if a field supplied Trane Communication Interface (TCI) module was added to the unit in the field, the unit configuration would need to be edited to reflect that feature.

**SERVICE** – used to selectively control outputs (for compressors, fans, etc.) when servicing or troubleshooting the unit. This menu is accessible only at the unit-mounted Human Interface Panel.

**STOP/AUTO** – when the chiller is in the stop mode, pressing the **AUTO KEY** will cause the UCM to go into either the Auto/Local or Auto/ICS mode, depending on the setpoint source setting.

**Chiller Capacity Control** – The Unit Control Module (UCM) will control leaving solution temperature to a user adjustable setpoint. The UCM monitors the leaving solution temperature sensor and determines how far away this temperature is from the leaving solution setpoint and how long it has been there. The rate at which capacity stages are added or subtracted is determined by a control integrator algorithm. This algorithm calculates a control integrator value based upon the inputs from the control response setpoint, the difference between the leaving solution setpoint and the leaving solution temperature, the number of capacity steps, and the design delta temperature. This function can be user defined for comfort or process control applications. The following setpoints are integrated into the capacity control algorithm:

**Leaving Solution Setpoint (LSS)** – The LSS is adjustable from the factory as standard within a range from 40-50° F. Three other possible ranges can be selected and ordered from the factory, 20-29, 30-39°, and 51-65° F. When these

options are selected, the unit hardware changes to allow the unit to operate under safe conditions.

**Design Delta Temperature setpoint** – the design delta T drop within the evaporator is adjustable from 4-20 °F in one degree increments. In addition, the control response setpoint can affect the speed of the UCM's response to changing cooling requirements. This value can be set through the HI to allow flexibility in maintaining precise control conditions.

**Chiller Freeze Protection** – The microprocessor will prevent the evaporator fluid from freezing by reducing chiller capacity, ultimately shutting down all compressors and sending a manually resettable diagnostic. The inputs for freeze protection are the low leaving solution temperature cutout and the leaving solution temperature.

**Evaporator Solution Flow Interlock** – The IntelliPak controls offer both an internal loss of flow protection, as well as an external evaporator flow switch interlock. Internally, the control algorithm will sense and compare the entering solution temperature and the leaving solution temperature to detect loss of flow during or after start-up. This input to the UCM shall have priority over all other commands and will stop the chiller and a manually resettable diagnostic will result. Additionally, an external field installed flow switch can be wired into the unit terminal strip; this feature can be enabled or disabled. When an open condition is detected for 6 seconds or longer, the chiller will shut down and send a manually resettable diagnostic alarm.

## Controls

---

**Head Pressure Control** – Condenser head pressure control is provided in the UCM by staging condenser fans on or off to maintain the saturated condensing temperature. This function will allow cooling operation down to 30° F as standard. Minimum on and off timing is built into the algorithm to prevent rapid cycling.

**Pump down** – This feature can be enabled or disabled through the Human Interface. When it is enabled, pump down will be initiated prior to shutting down the last capacity stage on each circuit by de-energizing a liquid line solenoid valve. Pump down is terminated by the opening of the low pressure switch, or 30 seconds after the cycle is initiated. On units equipped with hot gas bypass, pump down will be initiated upon termination of the hot gas bypass cycle.

**Chiller Solution Pump Control** – The UCM has two operating modes for the chiller solution pump control, Auto and On. The UCM additionally has a relay output that will energize/de-energize the chiller's solution pump control circuit. The relay is deenergized, stopping the pump, when emergency stop is activated. The solution pump relay is energized to run the pump in the following modes: freeze protection, normal cooling control, low ambient freeze protection, ice building and loop stabilization, and service mode. Modes that will request the pump to stop are ice building complete, ice building delay, unit stop and external auto/stop.

**Low Ambient Start Control** – Two functions are integrated into the control to allow operation in extreme conditions and still protect the overall system. Low ambient start control will allow compressor operation below 65° F. In order to avoid nuisance tripping, the low

pressure control will be bypassed for a period of time. If the low pressure control is still open at the end of the period, the compressor is shut down and the solenoid valve is opened. The loss of refrigerant flow protection is active in this sequence to additionally protect the chiller.

**Hot Start Control** – A high ambient start sequence will permit only one compressor to operate when the leaving solution temperature is in the user adjustable range of 60-80° F. When the leaving solution temperature falls below this high limit, the second compressor will be active.

**Low Ambient Compressor Lockout** – This function will lock out the compressor if the outdoor air temperature is below the low ambient compressor lock out temperature setpoint. This setpoint is adjustable at the Human Interface Panel (HI) between 0-60° F. Compressors will be locked out when outdoor air temperatures fall below that selected temperature and will be allowed to start again when the temperature rises 5° F above the setpoint.

**Compressor Lead/Lag** – Compressor lead/lag is a user-selectable feature through the Human Interface Panel available on all units. When enabled, the algorithm in the UCM will start compressors based upon the least number of starts and/or run time. This feature is not available with the hot gas bypass option.

**Emergency Stop Input** – A binary input is provided on the Unit Control Module (UCM) for installation of field provided switch or contacts for immediate shutdown of all unit functions.

**External Auto/Stop** – A set of contacts or switches can be field installed that will start and stop the chiller.

**Demand Limit** – The UCM will accept an input from a field installed device which will prevent one or more compressors from operating. The user can select the number of compressors to be turned off.

**Leaving Solution Reset** – This flexible option allows active leaving solution reset based on customer selectable inputs from the zone, entering solution temperature or outside air temperature. When the application is sensitive to one of these parameters, subcooling of critical zones is prevented.

### Optional Control Features

**Compressor Current Sensing** – This option will measure and average the amp draw of 2 phases of each compressor.

**Superheat/Subcooling Option** – This option will include the necessary temperature and pressure sensors to measure and calculate the chiller's superheat and subcooling numbers for each circuit. These temperatures and pressures, along with calculated values of superheat/subcool, will be displayed in the status menu of the Human Interface. No external refrigerant gauges need to be installed on the chiller for the system operator to check out these conditions.

**External Leaving Solution Setpoint** – Remote setpoint potentiometer can be ordered to allow adjustment of the leaving solution setpoint remotely.



## (20-60 Tons Interface)

# Controls

**Generic Building Automation System Module (GBAS)** — Two Generic Building Automation System Modules (GBAS) are available as an option to provide broad control capabilities for building automation systems, other than the Trane's Tracer™ system.

The **0-5 vdc input GBAS Module** contains 4 analog inputs, one binary input for demand limit, and 5 binary outputs.

**The 4 Analog inputs can accept a 0-5 vdc or a three wire potentiometer signal and be assigned to:**

1. Leaving Solution Setpoint
2. Ice Build Terminate Setpoint
3. Hot Start Load Limit Setpoint
4. Maximum Capacity Level Setpoint

**The 5 Binary Outputs can be assigned:**

1. Active Unit Diagnostics
2. Compressor running status
3. Maximum Capacity (all compressors running)
- 4,5. Open - Diagnostics can be grouped or individually assigned by the user and may be placed in these outputs.

The **0-10 vdc input GBAS module** contains 4 analog inputs, one binary input for demand limit, four analog outputs and one binary output.

The 4 analog inputs can accept a 0-10 vdc signal and be assigned to:

1. Leaving Solution Setpoint
2. Ice Build Terminate Setpoint
3. Hot Start Load Limit Setpoint
4. Maximum Capacity Level Setpoint

**The 4 analog outputs can be assigned to:**

1. Leaving Solution Temperature
2. Entering Solution Temperature
3. Saturated Condenser Temp. Ckt 1, 2
4. Evaporator Temp. Ckt 1, 2
5. Liquid Line Pressure Ckt1, 2
6. Suction Pressure Ckt 1, 2
7. Actual Capacity Level
8. Outdoor Air Temperature

**One Binary output can be assigned to:**

1. Active Unit Diagnostics
2. Compressors Running Status
3. Max Capacity

**Hot Gas Bypass (HGBP)** – The HGBP control allows unit operation below the minimum step of unloading. Hot gas bypass is initiated when the last capacity step is running and the capacity control algorithm generates a subtract command. HGBP remains energized until the load increases, the chiller freeze protection function is activated, a user defined run time has expired, the low pressure control is open, or the unit goes into ice building mode.

**Alarm and Max Capacity Relay** – These features are user selectable and are mutually exclusive of each other. If the alarm relay output is selected, it will provide a way to trigger a field supplied alarm whenever the UCM detects a fault requiring manual reset. The customer can assign which fault modes will trigger the alarm relay. The alarm will deenergize when the manual reset is cleared. When Max Capacity Output is selected, it will trigger a field installed device indicating the unit has reached its maximum cooling stage; this gives the customer the ability to turn on auxiliary systems to manage comfort.

**Ice Building Control** – A contact closure on the UCM allows either a field installed device or an ICS system to initiate the unit to operate in the ice building mode. In this mode normal chiller temperature control is bypassed and the unit runs fully loaded until ice building is complete. There are two optional ice building modes that can be selected through the HI. Ice building is terminated when the customer provide contacts are opened, Ice Building Stop is initiated from the Tracer, or the entering solution temperature reaches or drops below the ice building terminate setpoint.

**Option 1 - One time Ice building mode** allows the unit to run fully loaded until the entering solution temperature falls to the active ice building terminate setpoint (IBTS). When the entering solution temperature reaches the terminate setpoint, the unit will go through pumpdown if enabled and remain in Ice Complete standby mode until the ice build mode is terminated.

**Option 2 - Continuous ice build mode** allows the unit to run fully loaded until the entering solution temperature falls to the active ice building terminate setpoint (IBTS). When the entering solution temperature reaches the terminate setpoint, the unit will go through pumpdown if enabled, and remain in Ice build delay. The unit will remain in ice build stand-by until the ice build timer expires. The unit will then start the pump and wait for the loop stabilization timer to expire. The unit will run fully loaded until the entering solution temperature falls below the ice build termination setpoint. The unit will continue cycling through these ice building states until the Ice build mode is terminated or changed to option 1.



# Electrical Data - 60 HZ

(10-60 Ton)

**Table ED-1 — Electrical Data**

Tons	Model Number	Nameplate Voltage	Unit Wiring				Motor Data					
			Voltage Range	MCA	Max Fuse Size	Rec. Dual Element	Compressor (Ea)			Fans (Ea)		
							Qty.	RLA	LRA	Qty	KW	FLA
10	CGA120B1	208-230/60/1	187-254	74	100		2	30.0	169	1	.95	6.0
	CGA120B3	208-230/60/3	187-254	42	50		2	16.0	137	1	.95	6.0
	CGA120B4	460/60/3	414-506	23	30		2	9.0	62	1	.95	2.7
	CGA120BW	575/60/3	518-632	18	25		2	7.1	50	1	.95	2.0
15	CGA180B3	208-230/60/3	187-254	66	90		2	26.6	208	2	1.03	3.1
	CGA180B4	460/60/3	414-506	35	45		2	14.3	91	2	1.03	1.6
	CGA180BW	575/60/3	518-632	28	35		2	11.3	68	2	1.03	1.2
20	CGAF-C20	200/60/3	180-220	98	125	110	2	39.4	269	2	0.9	4.1
		230/60/3	208-254	98	125	110	2	39.4	251	2	0.9	4.1
		460/60/3	416-508	44	60	50	2	17.2	117	2	0.9	1.8
		575/60/3	520-635	33	45	40	2	13.2	94	2	0.9	1.4
25	CGAF-C25	200/60/3	180-220	124	175	150	2	39.3,56.9	269,409	3	0.9	4.1
		230/60/3	208-254	124	175	150	2	39.3,56.9	251,376	3	0.9	4.1
		460/60/3	416-508	56	80	70	2	17.1,25.4	117,178	3	0.9	1.8
		575/60/3	520-635	44	60	50	2	13.8,20.2	94,143	3	0.9	1.4
30	CGAF-C30	200/60/3	180-220	146	200	175	2	56.9	409	4	0.9	4.1
		230/60/3	208-254	146	200	175	2	56.9	376	4	0.9	4.1
		460/60/3	416-508	65	80	80	2	25.1	178	4	0.9	1.8
		575/60/3	520-635	51	70	60	2	19.9	143	4	0.9	1.4
40	CGAF-C40	200/60/3	180-220	187	225	200	4	39.4	269	4	0.9	4.1
		230/60/3	208-254	186	225	200	4	39.4	251	4	0.9	4.1
		460/60/3	416-508	82	90	90	4	17.2	117	4	0.9	1.8
		575/60/3	520-635	62	70	70	4	13.2	94	4	0.9	1.4
50	CGAF-C50	200/60/3	180-220	224	250	250	4	35.5,55.5	269,409	6	0.9	4.1
		230/60/3	208-254	223	250	250	4	35.5,55.5	251,376	6	0.9	4.1
		460/60/3	416-508	98	110	110	4	15.5,24.2	117,178	6	0.9	1.8
		575/60/3	520-635	77	90	90	4	12.4,19.4	94,143	6	0.9	1.4
60	CGAF-C60	200/60/3	180-220	270	300	300	4	56.9	409	6	0.9	4.1
		230/60/3	208-254	269	300	300	4	56.9	376	6	0.9	4.1
		460/60/3	416-508	120	125	125	4	25.4	178	6	0.9	1.8
		575/60/3	520-635	95	110	100	4	20.2	143	6	0.9	1.4

**Notes:**

1. MCA: Minimum Circuit Ampacity is 125% of the largest compressor RLA plus 100% of the other compressor(s) RLA plus the sum of the condenser fan FLA plus any other load rated at 1 AMP or more
2. Maximum Fuse Size: 225% of the largest compressor RLA plus 100% of the other compressor(s) RLA plus the sum of the condenser fan FLA plus any other load rated at 1 AMP or more
3. Recommended Dual Element Fuse Size: 150% of the largest compressor RLA plus 100% of the other compressor(s) RLA plus the sum of the condenser fan FLA plus any other load rated at 1 AMP or more.
4. RLA: Rated in accordance with UL standard 1995.
5. Local codes may take precedence.
6. All units are across the line starting. Compressors will never start simultaneously.
7. One 115/60/1, 15 AMP jobsite provided power connection is required to operate the evaporator heat tape.

**Load Definitions**

LOAD1 = Current of the largest motor – compressor or fan motor

LOAD2 = Sum of the currents of all remaining motors

LOAD3 = Current of electric heaters

LOAD4 = Any other load rated at 1 amp or more

$$MCA = (1.25 \times LOAD1) + LOAD2 + LOAD4$$

$$MOP = (2.25 \times LOAD1) + LOAD2 + LOAD4$$

Select a fuse rating equal to the MOP value. If the MOP value does not equal a standard fuse size as listed in NEC 240-6, select the next **lower** standard fuse rating.

**NOTE:** If selected MOP is less than the MCA, then reselect the lowest standard maximum fuse size which is equal to or larger than the MCA, provided the reselected fuse size does not exceed 800 amps.

$$RDE = (1.5 \times LOAD1) + LOAD2 + LOAD4$$

Select a fuse rating equal to the RDE value. If the RDE value does not equal a standard fuse size as listed in NEC 240-6, select the next **higher** standard fuse rating.

**NOTE:** If the selected RDE is greater than the selected MOP value, then reselect the RDE value to equal the MOP value.

$$DSS = 1.5 \times (LOAD1 + LOAD2 + LOAD3 + LOAD4)$$

Select a disconnect switch size equal to or larger than the DSS value calculated.



# Electrical Data - 50 HZ

(10-60 Ton)

**Table ED-2 — Electrical Data**

Tons	Model Number	Nameplate Voltage	Unit Wiring				Motor Data					
			Voltage Range	MCA	Max Fuse Size	Rec. Dual Element	Compressor (Ea)			Fans (Ea)		
							Qty.	RLA	LRA	Qty	KW	FLA
10	CGA100BD	380-415/50/3	342-456	21.0	25	-	2	8.0	62	1	0.57	2.7
15	CGA150BD	380-415/50/3	342-456	30.0	40	-	2	11.9	91	2	0.33	1.6
20	CGAF-C20	380/50/3	342-418	44	60	50	2	17.2	110	2	0.75	1.7
		415/50/3	373-456	44	60	50	2	17.2	110	2	0.75	1.7
25	CGAF-C25	380/50/3	342-418	55	80	70	2	17.3/25.2	110/174	3	0.75	1.7
		415/50/3	373-456	55	80	70	2	17.3/25.2	110/174	3	0.75	1.7
30	CGAF-C30	380/50/3	342-418	65	80	80	2	25.2	174	4	0.75	1.7
		415/50/3	373-456	65	80	80	2	25.2	174	4	0.75	1.7
40	CGAF-C40	380/50/3	342-418	81	90	90	4	17.2	110	4	0.75	1.7
		415/50/3	373-456	81	90	90	4	17.2	110	4	0.75	1.7
50	CGAF-C50	380/50/3	342-418	97	110	110	4	15.5/24.2	110/174	6	0.75	1.7
		415/50/3	373-456	97	110	110	4	15.5/24.2	110/174	6	0.75	1.7
60	CGAF-C60	380/50/3	342-418	119	125	125	4	25.2	174	6	0.75	1.7
		415/50/3	373-456	119	125	125	4	25.2	174	6	0.75	1.7

**Notes:**

- MCA: Minimum Circuit Ampacity is 125% of the largest compressor RLA plus 100% of the other compressor(s) RLA plus the sum of the condenser fan FLA plus any other load rated at 1 AMP or more.
- Maximum Fuse Size: 225% of the largest compressor RLA plus 100% of the other compressor(s) RLA plus the sum of the condenser fan FLA plus any other load rated at 1 AMP or more.
- Recommended Dual Element Fuse Size: 150% of the largest compressor RLA plus 100% of the other compressor(s) RLA plus the sum of the condenser fan FLA plus any other load rated at 1 AMP or more.
- RLA: Rated in accordance with UL standard 1995.
- Local codes may take precedence.
- Control kw includes operational controls only. Does not include evaporator heat tape.
- All units are across the line starting. Compressors will never start simultaneously.
- One 240/50/1, 5 AMP jobsite provided power connection is required to operate the evaporator heat tape.

# Dimensional Data (10Ton)

Figure DD-1 — CGA-120B Unit Dimensions

TOP DISCHARGE AREA SHOULD BE VERTICALLY UNRESTRICTED FOR 100[2540] MINIMUM. UNIT SHOULD BE PLACED SO ROOF RUN-OFF WATER DOES NOT POUR DIRECTLY ON UNIT.

1 3/4[44.5] DIA. HOLE (HIGH VOLTAGE POWER ENTRY)

7/8[22.2] DIA. HOLE (LOW VOLTAGE CONTROL WIRING POWER ENTRY)

2 3/4[70] DIA. ENTRY WITH 1 1/2[38.1] NPTF WATER INLET FITTING

2 3/4[70] DIA. ENTRY WITH 1 1/2[38.1] NPTF WATER OUTLET FITTING

1 1/4[31.8] DIA. LIFTING HOLE, TYP. OF 4

7/8[22.2] DIA. HOLE (ELECTRIC HEAT TAPE POWER ENTRY)

CLEARANCE PERIMETER (NOTE 1)

1 1/2[38.1] DIA. PRESSURE GAUGE ENTRY HOLE

7/16[11.1] DIA. ISOLATOR MOUNTING HOLES (INSIDE HOLES—4 PLACES)

2[50.8] DIA. KNOCKOUT HEAD PRESSURE CONTROL ACCESSORY WIRING ENTRY

3 3/4[95.3] DIA. KNOCKOUT TYP. OF 4, TO MOUNT PRESSURE GAGE KIT ACCESSORY

7/8[22.2] DIA. KNOCKOUT TYP. OF 2, FOR DAYTIME ACCESSORY CONTROL WIRING ENTRY

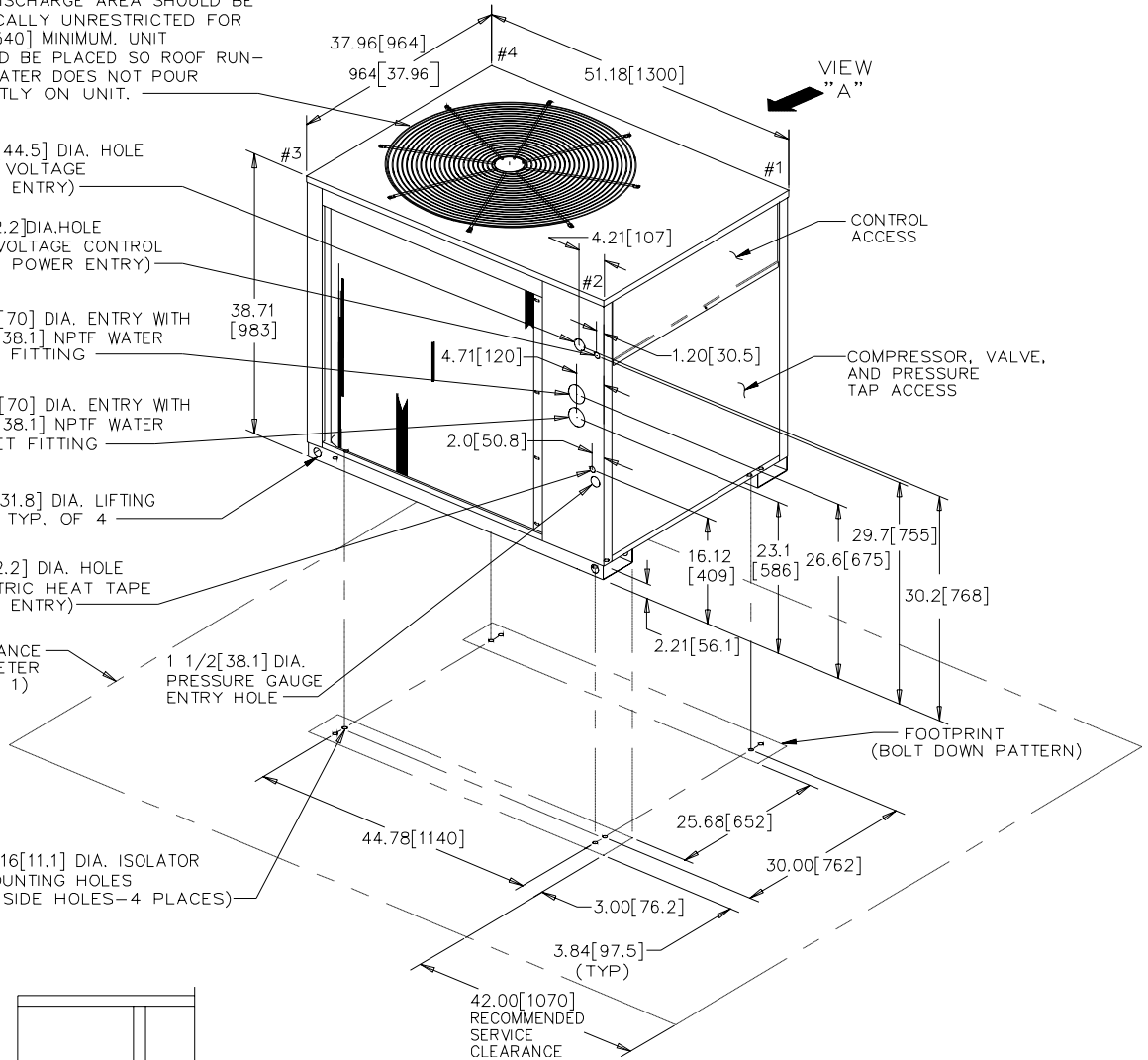

VIEW "A"

Notes:

1. Minimum clearance around the perimeter of the unit is 3 feet. Minimum clearance between adjacent units is 6 feet.
2. When installing water pipes, be certain to route them away from the compressor access panels to allow for compressor servicing or replacement.

# Dimensional Data (15 Ton)

Figure DD-2 — CGA-180B Unit Dimensions

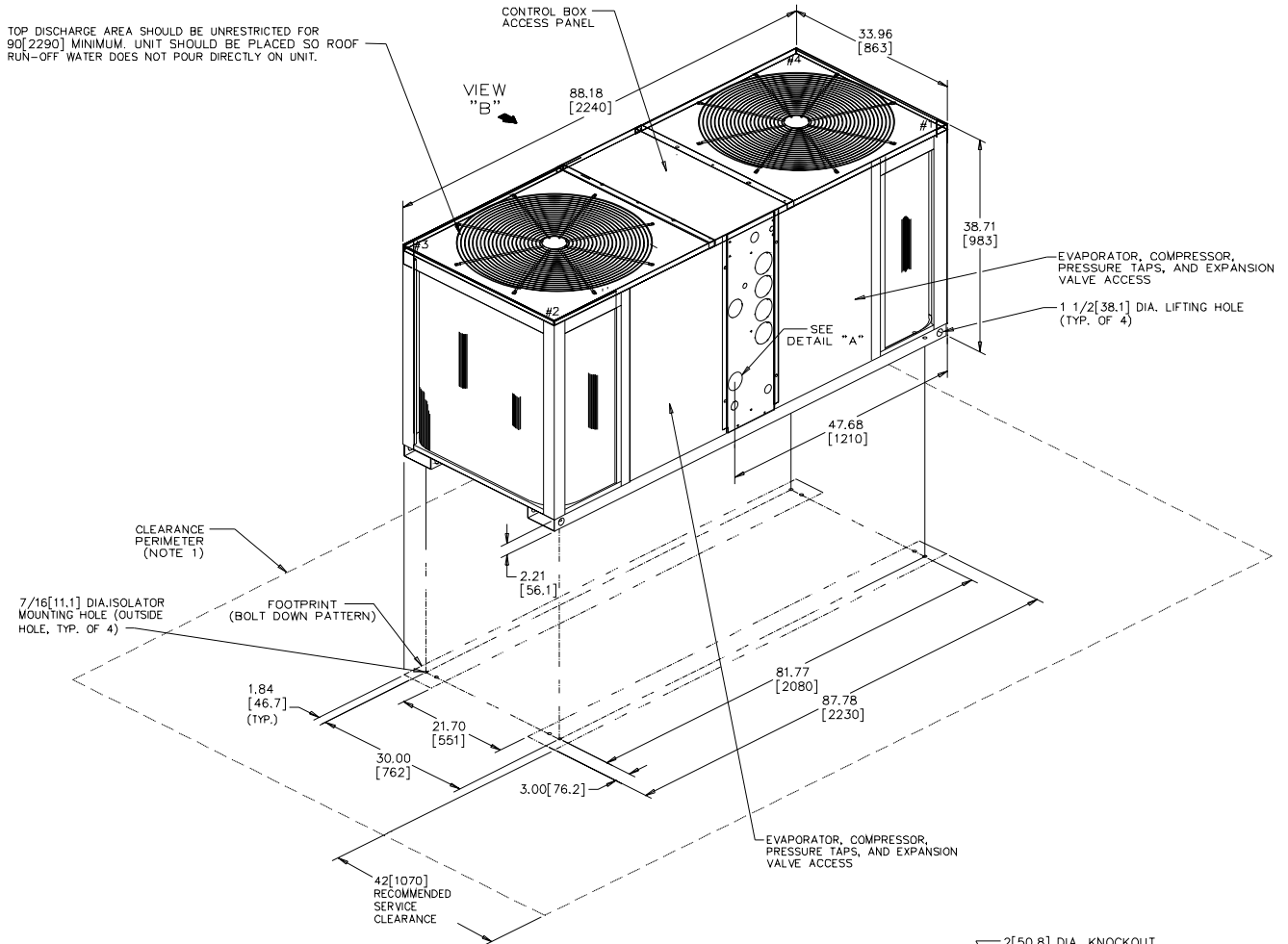

Notes:

1. Minimum clearance around the perimeter of the unit is 3 feet. Minimum clearance between adjacent units is 6 feet.
2. When installing water pipes, be certain to route them away from the compressor access panels to allow for compressor servicing or replacement.

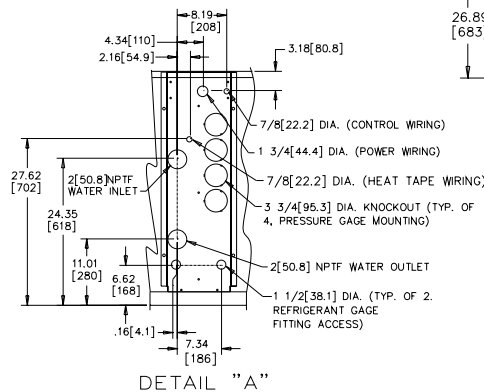
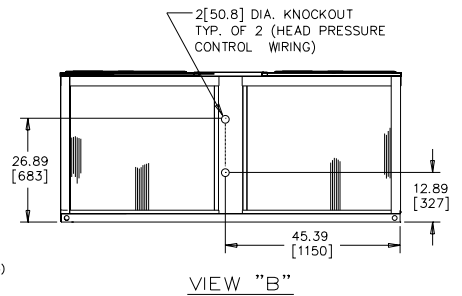

# Dimensional Data (20Ton)

Figure DD-3 —Figure 37-1 — CGAF-C20 Unit Dimensions

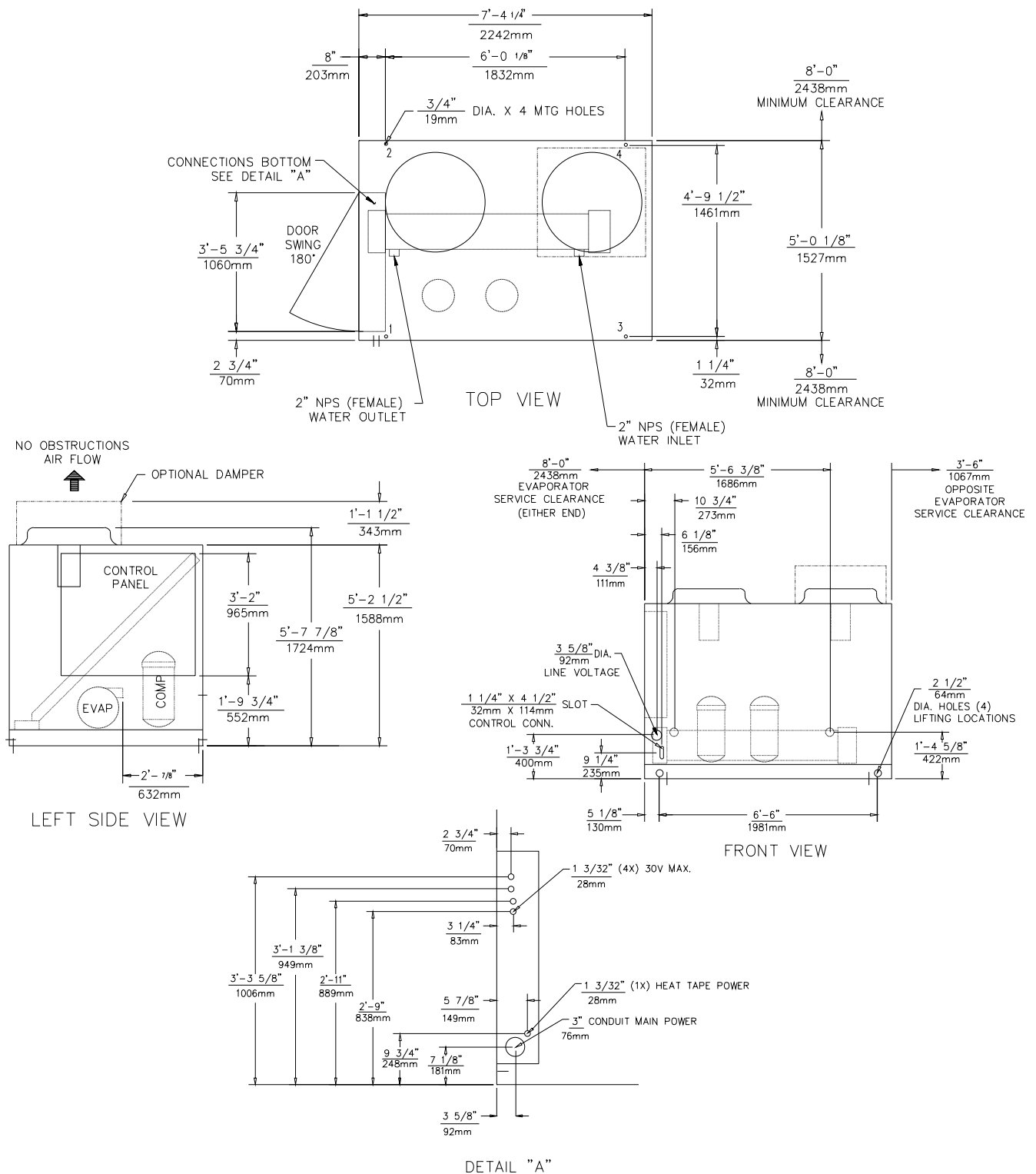

# Dimensional Data (25Ton)

Figure DD-4 — CGAF-C25 Unit Dimensions

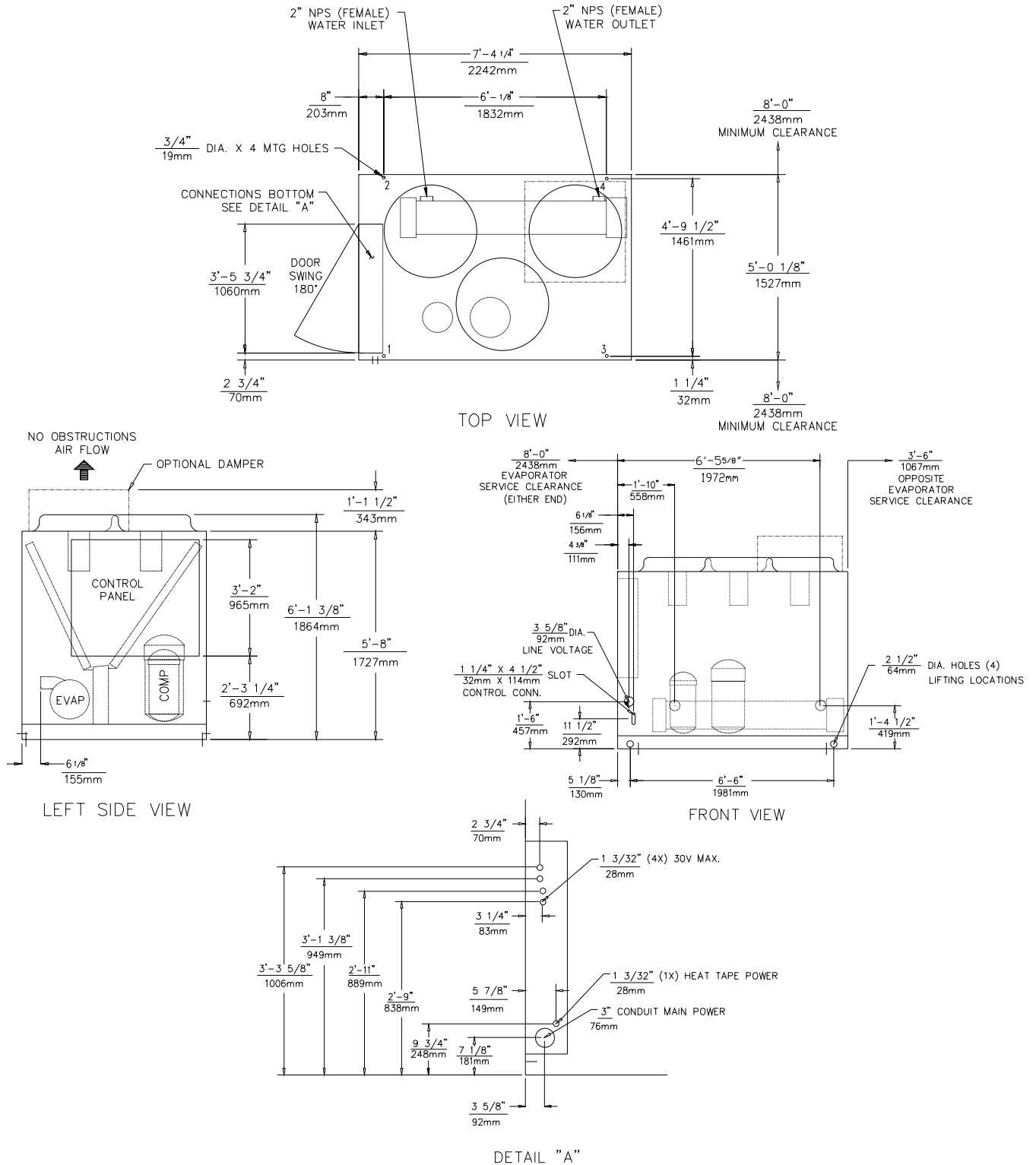

# Dimensional Data (30Ton)

Figure DD-5 — CGAF-C30 Unit Dimensions

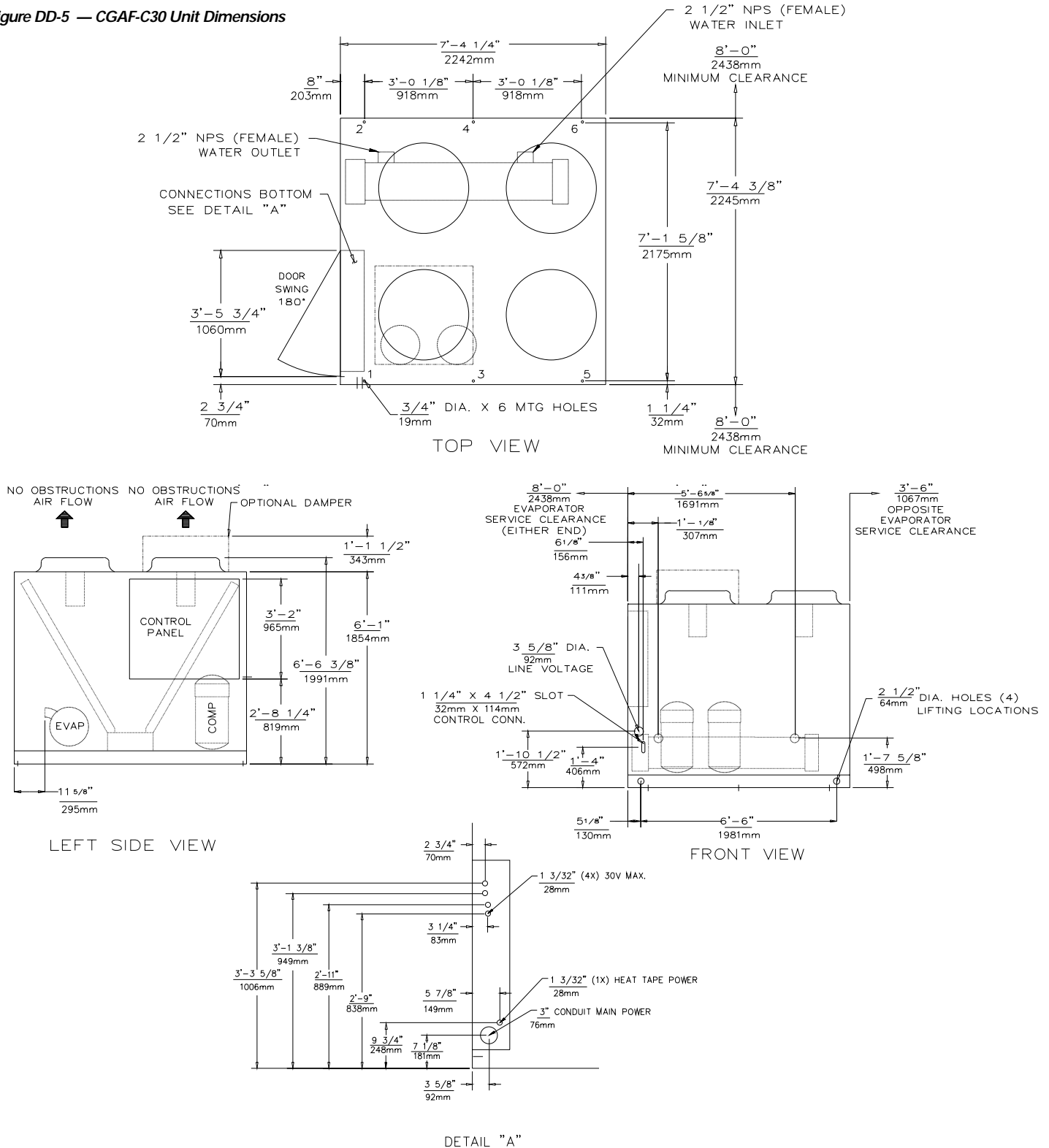

# Dimensional Data (40Ton)

Figure DD-6 — CGAF-C40 Unit Dimensions

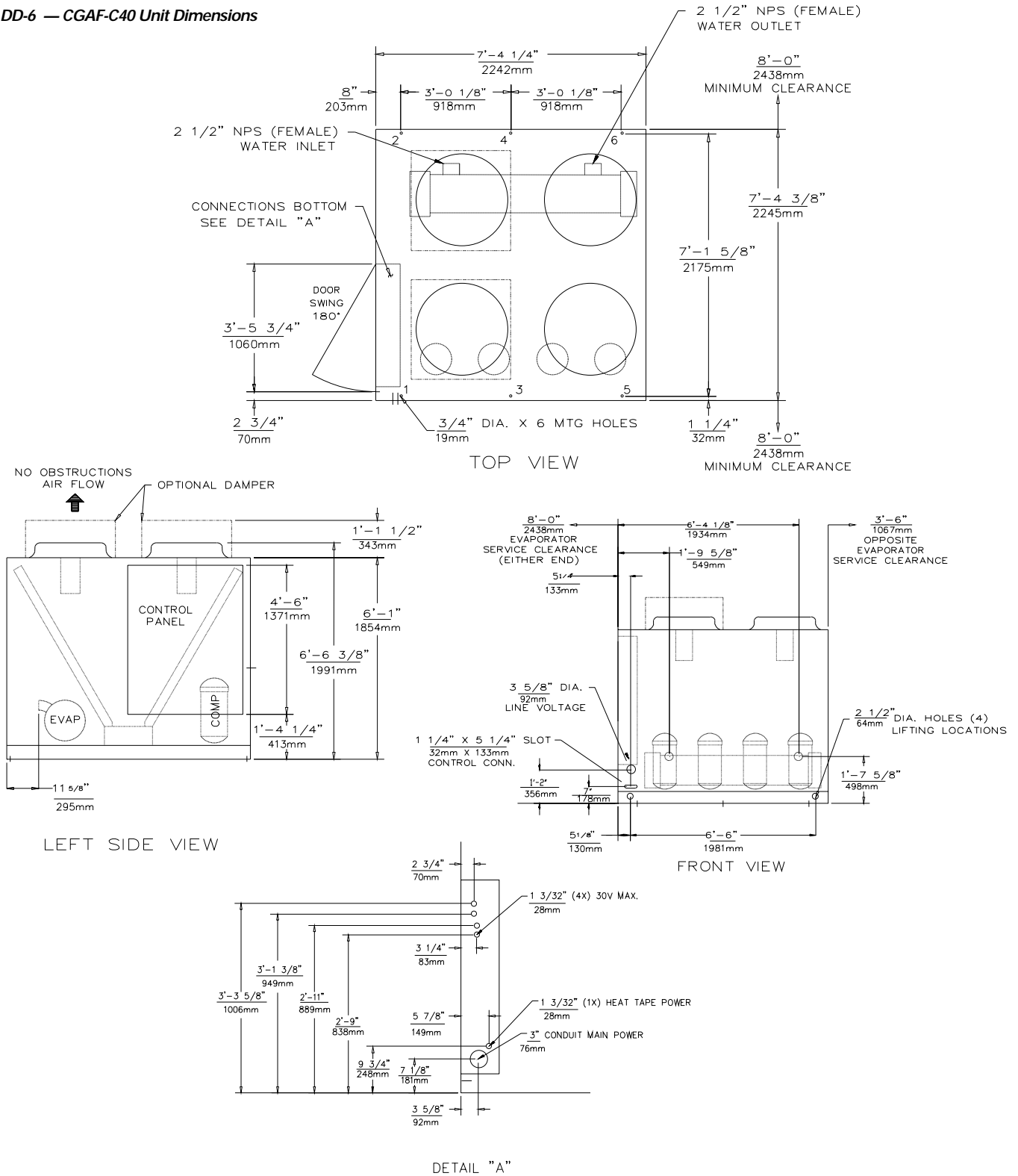

# Dimensional Data (50 Ton)

Figure DD-7 — CGAF-C50 Unit Dimensions

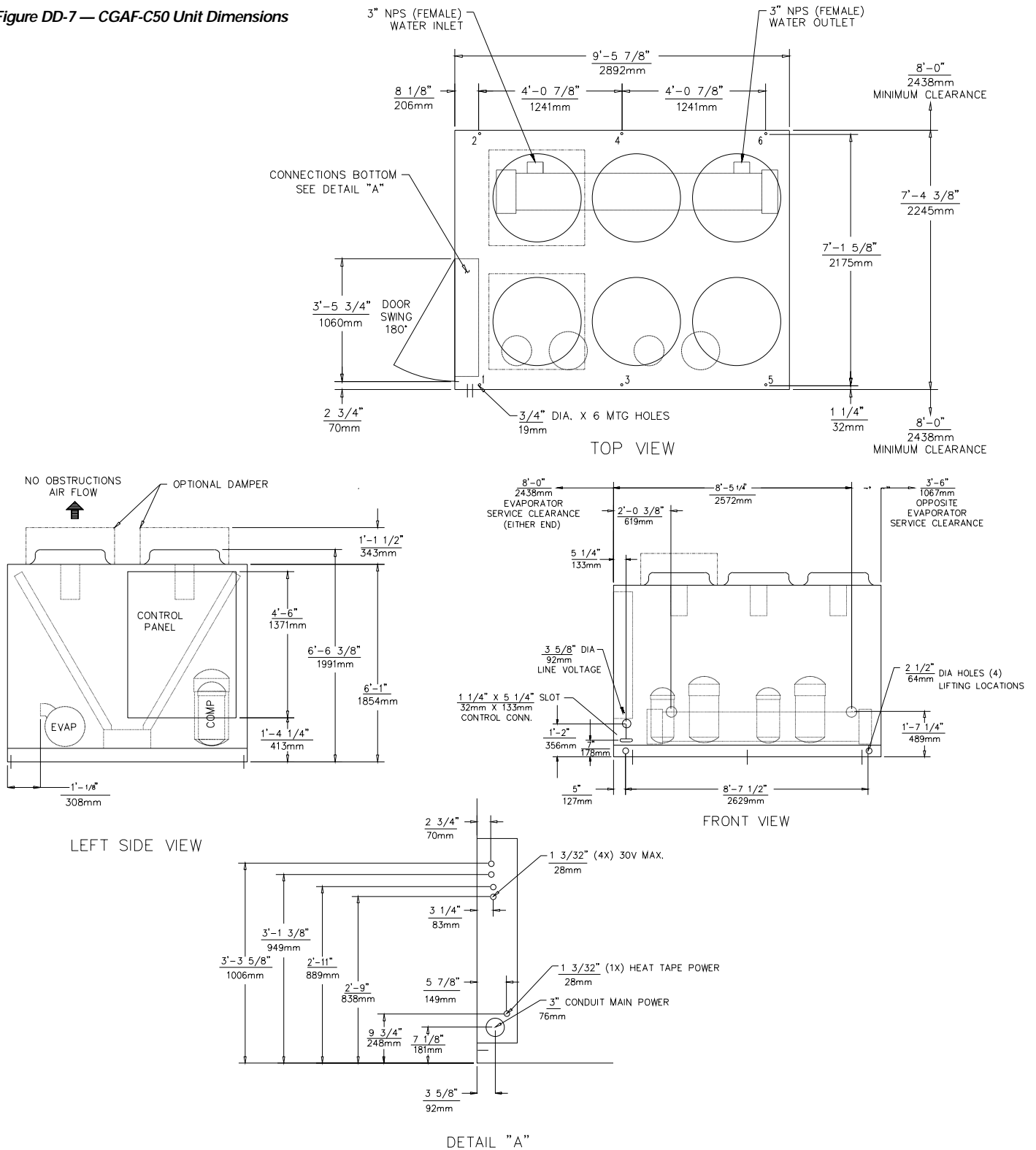

# Dimensional Data (60 Ton)

Figure DD-8—CGAF-C60 Unit Dimensions

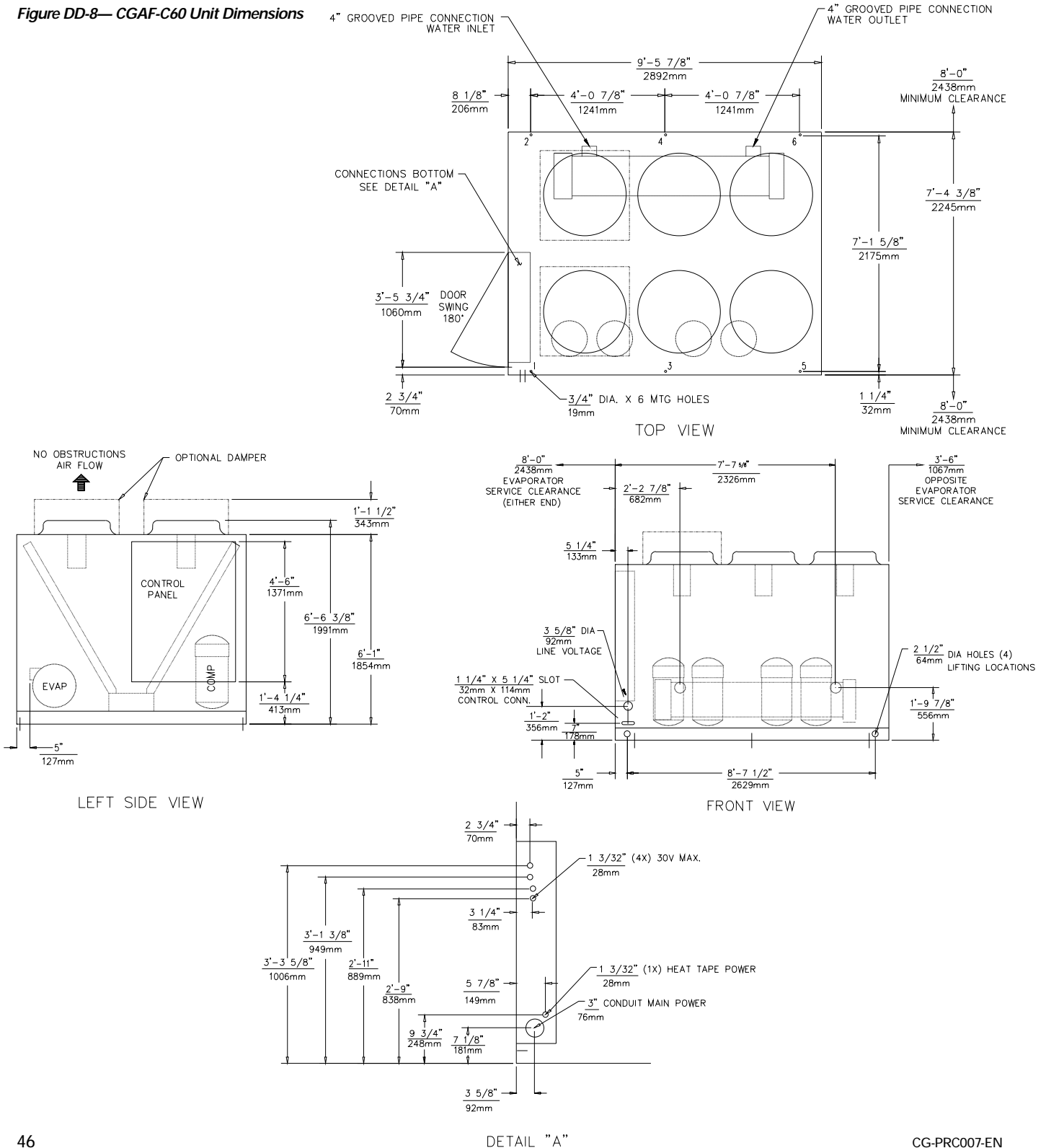

(10-60 Ton)

# Weights

**Table W-1 — Approximate Corner Weights (lbs) 10-Ton Unit**

Tons	Model Number	Isolator Loading				Operating Wt.	Shipping Wt.
		1	2	3	4		
10	CGA 120B	161	164	103	101	529	576

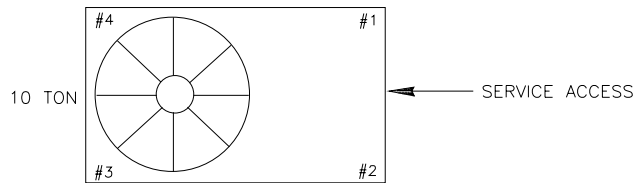

**Table W-2 — Approximate Corner Weights (lbs) 15-Ton Unit**

Tons	Model Number	Isolator Loading				Operating Wt.	Shipping Wt.
		1	2	3	4		
15	CGA 180B	186	187	208	207	788	871

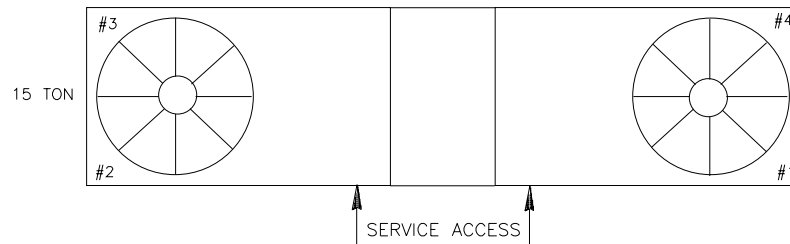

**Table W-3 — CGAF Unit Weights (lbs)**

Tons	Model Number	Condenser Fin Type	Isolator Loadings Location (lbs)						Operating Weight (lbs)	Shipping Weight (lbs)
			1	2	3	4	5	6		
20	CGAFC20	Aluminum	654	586	449	402	-	-	2091	1994
		Copper	710	630	513	455	-	-	2308	2211
25	CGAFC25	Aluminum	684	656	478	459	-	-	2277	2187
		Copper	752	719	558	534	-	-	2563	2474
30	CGAFC30	Aluminum	884	641	641	465	399	289	3319	3223
		Copper	958	680	723	513	488	346	3708	3614
40	CGAFC40	Aluminum	573	674	544	640	516	606	3553	3438
		Copper	625	725	609	706	592	687	3944	3828
50	CGAFC50	Aluminum	712	838	642	756	572	673	4193	4072
		Copper	793	916	733	847	672	777	4738	4618
60	CGAFC60	Aluminum	875	1135	805	1044	734	952	5545	5289
		Copper	1013	1269	958	1200	903	1131	6474	6218

**Notes:**

1. Operating weights include refrigerant and water, but do not include weight of accessories.
2. Shipping weights include refrigerant and crating.
3. Refer to dimensional data for location of isolator loading points.

20-25 Tons

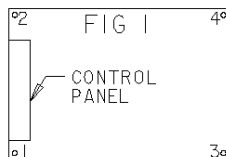

30-60 Tons

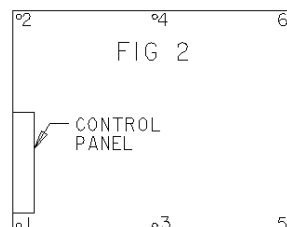



# Mechanical Specifications

(10-15Ton)

## General

Units shall be assembled on heavy gauge steel mounting/lifting rails and shall be weatherproofed. Units shall include hermetic scroll compressors, plate fin condenser coil, fan(s) and motor(s), controls and complete factory installed operating charge of oil and R-22 refrigerant. Operating range shall be between 115°F and 0°F. Units shall be either UL or CSA certified and rated in accordance with ARI Standard 550/590-98.

## Casing

Unit casing shall be constructed of 18-gauge zinc coated heavy gauge, galvanized steel. Exterior surfaces shall be cleaned, phosphatized and finished with a weather-resistant baked enamel finish. Units surface shall be tested to withstand a 500 consecutive hour salt spray durability test. Units shall have removable panels which allow access to major components and controls.

## Refrigeration System

Unit shall have two separate and independent refrigeration circuits. Each refrigeration circuit shall have integral subcooling circuits. Refrigeration filter driers and sightglasses shall be provided as standard.

## Compressors

Unit shall have two Trane direct-drive hermetic scroll compressors with centrifugal oil pump and provide positive lubrication to all moving parts. Motor shall be suction gas-cooled and shall have a voltage utilization range of plus or minus 10 percent of nameplate voltage. Crankcase heater, internal temperature and current-sensitive motor overloads shall be included for maximum protection. External high and low pressure cutout devices shall be provided.

## Condenser Coil

Coils shall be 3/8" copper tubes mechanically bonded to configured aluminum plate fin as standard. Factory

pressure and leak tested to 420 psig minimum air pressure and design working pressure shall be 376 psig. Metal grilles with PVC coating for coil protection are optional.

## Evaporator

The evaporator shall have independent dual refrigerant circuits. The evaporator shall be braze plate construction with a waterside working pressure of 350 psig and a refrigerant-side working pressure of 300 psig. One water pass with a drain connection.

## Condenser Fan and Motor(s)

Direct-drive, statically and dynamically balanced propeller fan(s) with aluminum blades and electro-coated steel hubs shall be used in draw-thru vertical discharge position. Either permanently lubricated totally enclosed or open construction motors shall be provided and shall have built-in current and thermal overload protection. Motor(s) shall be ball bearing type.

## Controls

The chiller shall be completely factory wired with necessary controls and contactor pressure lugs or terminal block for power wiring. Control wiring shall be 24-volt control circuit which includes fusing and control transformer. Time delay timers to prevent compressors in dual compressor units from simultaneous start-up and anti-recycle timers shall be standard.

## Low Ambient Operation

Standard units shall start and operate to approximately 50°F. Optional head pressure control accessory permits operation at lower temperature extremes (see "General Data" section of this catalog).

## OPTIONS

### Field Installed

#### Low Ambient Head Pressure Control

Shall modulate the rpm of unit outdoor fan motor in response to unit head pressure. Accessory provides unit cooling operation to outdoor temperatures of 0°F.

## Vibration Isolation Packages

Shall reduce transmission of noise and vibration to building structures, equipment and adjacent spaces. Packages shall be available in either neoprene-in-shear or spring-flex types.

## Condenser Coil Guard

Metal grille with PVC coating shall be provided to alleviate coil damage.

## Power Supply Monitor

Shall provide protection against phase loss/reversal, phase imbalance, incorrect phase sequence and low voltage.

## Elapsed Time Meter/Number Starts Counter

Shall record number of compressor starts and operating hours of each compressor.

## Integrated Comfort™ Systems (ICS) Interface

Shall provide the ability to communicate with the Trane Tracer™ building management system via TCM.

## Flow Switch

Required as a safety interlock to prevent operation of unit without evaporator flow.

## Gauges

Field-installed gauges monitor suction and discharge pressures.

## Factory Installed

### Black Epoxy Coil

The black epoxy coating provides excellent protection against aluminum corrosion.

### Hot Gas Bypass

Allows unit operation below the minimum step of unloading.

### Low Leaving Solution Temperature Applications

Allows leaving solution temperatures as low as 20°F. This capability is standard from the factory on both 10 and 15-ton models.



# Mechanical Specifications

(20-60Ton)

## GENERAL

All chillers are factory run-tested to confirm proper operation. Units are checked on a computer-based test stand at typical ambient and water conditions and control operation is monitored. Units ship with a full operating charge of refrigerant and oil.

Units are constructed of 14-gauge welded galvanized steel frame with 14 and 16-gauge galvanized steel panels and access doors. Unit surface is phosphatized and finished with an air-dry paint. This air-dry paint finish exceeds 672 consecutive hour salt spray resistance in accordance with ASTM B117.

## Evaporator

Tube-in-shell design with seamless internally finned copper tubes, roller-expanded into tube sheets. Chiller is designed, tested and stamped in accordance with ASME code for

refrigerant side working pressure of 225 psig. The chiller is designed to withstand a waterside working pressure of 300 psig. It has one water pass with a series of internal baffles. Each shell includes a drain and a vent connection, fittings for temperature control sensors and 3/4-inch insulation ( $K = 0.26$ ). Heat tape, which is thermostat controlled, protects the evaporator to an ambient of  $-20^{\circ}\text{F}$ .

## Condenser

Air-cooled condenser coils have configured aluminum fins mechanically bonded to seamless copper tubing and integral subcooling circuits. Condensers are factory leak-tested with air underwater at 425 psig air pressure.

Direct-drive vertical discharge condenser fans are statically and dynamically balanced. Three-phase condenser fan motors with permanently lubricated ball bearings and three-phase thermal overload protection. Optional low ambient units start and operate to  $0^{\circ}\text{F}$  with electronic damper assemblies for head pressure control.

Decorative grilles provide protection from exterior damage to coil surface and other interior unit components. Grilles are factory mounted, louvered, galvanized steel mesh panels finished with an air-dry paint. Grilles will cover all open ends of units.

## Compressors

Trane 3-D<sup>®</sup> Scroll compressors have simple mechanical design with only three major moving parts. Scroll type compression provides inherently low vibration. The 3-D Scroll provides a completely enclosed compression chamber which leads to increased efficiency. Exhaustive testing on the 3-D Scroll, including start up with the shell full of liquid, has proven that slugging does not fail involutes. Direct-drive, 3600 rpm, suction gas-cooled hermetic motor. Trane 3-D Scroll compressor includes centrifugal oil pump, oil level sightglass and oil charging valve. Each compressor shall have crankcase heaters installed, properly sized to minimize the amount of liquid refrigerant present in the oil sump during off cycles.

## Refrigerant Circuits and Capacity Modulation

Twenty through 30-ton sizes have a single refrigerant circuit. Forty through 60-ton sizes have dual refrigerant circuits. Each refrigerant circuit has two Trane 3-D Scroll compressors, piped in

parallel, with a passive oil management system. Passive oil management system maintains proper oil levels within compressors and has no moving parts. Each refrigerant circuit includes an expansion valve, a filter drier, and a liquid line sightglass with moisture indicator. Capacity modulation is achieved by turning compressors on and off. Twenty through 30-ton sizes have two capacity stages. Forty, 50 and 60-ton sizes have four capacity stages. The standard leaving chilled water temperature range is  $40^{\circ}\text{F}$  to  $50^{\circ}\text{F}$ . Options are available for leaving chilled solution temperature ranges from  $20^{\circ}$  to  $29^{\circ}\text{F}$ ,  $30^{\circ}$  to  $39^{\circ}\text{F}$ , and  $51^{\circ}$  to  $65^{\circ}\text{F}$ .

## Unit Controls

Compressor contactors and unit controls are in a weathertight enclosure with knockouts for jobsite installed wiring. The unit controller shall be suitable to control leaving chilled solution temperature for comfort or process applications, automatic compressor sequencing, condenser fan sequencing, load limiting and anti-recycle functions. Failure protections include loss of chilled solution flow, chiller freeze protection, chilled solution flow interlock, head pressure control, pump down control, low ambient start, hot start control, and low ambient lockout. Leaving and entering solution temperature sensor is factory installed. Controls include auto/stop switch, a leaving water temperature setpoint adjustment, a Delta T adjustment viewable through the unit Human Interface digital display.

## Unit Controller

DDC microprocessor controls shall be provided to control all unit functions. The control system shall be suitable to



# Mechanical Specifications

(20-60Ton)

control comfort and process applications. The controls shall be factory-installed and mounted in the main control panel. All factory-installed controls shall be fully commissioned (run tested) at the factory. The unit shall have a Human Interface Panel with a 16 key keypad, a 2 line X 40 character clear English display as standard to provide the operator with full adjustment and display of control data functions. The unit controls shall be used as a stand-alone controller, or as part of a building management system involving multiple units.

## 1

The unit shall be equipped with a complete microprocessor control system. This system shall consist of temperature and pressure (thermistor and transducer) sensors, printed circuit boards (modules), and a unit mounted Human Interface Panel. Modules (boards) shall be individually replaceable for ease of service. All microprocessors, boards and sensors shall be factory mounted, wired and tested.

The microprocessor boards shall be stand-alone DDC controls not dependent on communications with an on-site PC or a Building Management Network. The microprocessors shall be equipped with on-board diagnostics, indicating that all hardware, software and interconnecting wiring are in proper operating condition.

The modules (boards) shall be protected to prevent RFI and voltage transients from affecting the board's circuits. All field wiring shall be terminated at separate, clearly marked terminal strip. Direct field wiring to the

I/O boards is not acceptable.

The microprocessor's memory shall be non-volatile EEPROM type requiring no battery or capacitive backup, while maintaining all data.

## 2

Zone sensor will be available for zone temperature reset.

## 3

The Human Interface Panel's keypad display character format shall be 40 characters x 2 lines. The character font shall be 5 x 7 dot matrix plus cursor. The display shall be Supertwist Liquid Crystal Display (LCD) with blue characters on a gray/green background which provides high visibility and ease of interface. The display format shall be in clear English. Two or three digit coded displays are not acceptable.

## 4

The keypad shall be equipped with 16 individual touch-sensitive membrane key switches. The switches shall be divided into four separate sections and be password protected from change by unauthorized personnel. The six main menus shall be STATUS, SETPOINTS, DIAGNOSTICS, SETUP, CONFIGURATION and SERVICE MODE.

Standard power connections include main three-phase power and a single 115-volt, 24-volt single-phase connection that handles unit controls.

Unit accepts any of these jobsite supplied contact closures for:

*External Auto/Stop* - A contact closure that will start and stop the unit operation.

*External Chilled Solution Interlock* - A chilled solution pump interlock in combination with a flow switch is not required for unit protection since the unit controller senses loss of flow. If additional flow protection is required, or if the pump contactor is used to schedule the unit, this input may be used.

*Kw Demand Limit* - Unit will only be allowed to operate on user selected quantity of compressors in order to maintain the building demand limit.

## Ice Building

Two ice building modes are optional and can be ordered on the unit. The two modes are one time ice build mode and continuous ice build mode.

## Miscellaneous Options

### Trane Communications Interface Module (TCI)

Provides capability to communicate with a Trane ICS<sup>™</sup> system.

### Compressor Current Sensing (CSM)

This option measures and averages amp draw on each compressor.

### Unit Mounted Disconnect

Non-fused, factory installed, and located inside the main control box, this disconnect switch features an external handle that allows the operator to disconnect unit power without having to open the control box door.

### Isolators

Spring or neoprene-in-shear isolators available for jobsite installation.

### Superheat/Sub-Cooling

In place of externally mounted refrigerant gauges, a module can be ordered that will calculate and display on the Human Interface (HI) each circuit's superheat and subcooling temperatures.

### Hot Gas Bypass

Although unnecessary on scroll chillers for comfort applications (due to scroll cycling capabilities), hot gas bypass is still available for applications requiring close temperature control at low load conditions.

### Generic Building Automation System (GBAS)

Two modules are available to integrate building automation systems other than Trane. The modules are designed for either 0-5 vdc or 0-10 vdc signals.



# Mechanical Specifications

(20-60Ton)

## Remote Human Interface (RHI) Panel

The Remote Human Interface Panel can perform all the same functions as unit mounted Human Interface Panel, with the exception of the Service Mode.

The field installed RHI can monitor and control up to 4 chillers. The RHI is suitable for mounting inside a building, up to 5,000 feet from the unit. The RHI is wired to the IPCB mounted in each chiller with a wire pair communication wiring and 24V control wiring.

## Remote Setpoint Potentiometer

Field installed option that allows remote adjustment of the leaving solution setpoint.

## Zone Sensor (Chilled Solution Reset)

Field installed zone sensor that allows the leaving chilled solution temperature to be reset by the zone temperature.

## Flow Switch

This field installed option indicates loss of evaporator flow – available for field installation.

## Copper Fin Condenser Coils

Copper fins mechanically bonded to seamless copper tubes are available for use in corrosive atmospheres

## Electronic Low Ambient Damper(s)

Allows the unit to operate down to 0° F outdoor ambient conditions.

## Inter-Processor Communication Bridge (IPCB)

This module provides an amplified and filtered version of the IPC link for connection to a Remote Human Interface (RHI) Panel. Each chiller that is tied into a RHI must have a IPCB installed.

## Other Options

In addition to all of these options, Trane can offer in-house design for many applications, including special coil coating.



The standard ARI rating condition full load and IPLV are ARI certified. All other ratings, including the following, are outside the scope of the certification program and are excluded:

- Glycol
- 50 Hz



**TRANE®**

Trane  
An American Standard Company  
[www.trane.com](http://www.trane.com)

For more information contact your  
local district office, or e-mail us at  
[comfort@trane.com](mailto:comfort@trane.com)

Literature Order Number	CG-PRC007-EN
File Number	PL-RF-CG-PRC007-EN-01-2002
Supersedes	CG-PRC007-EN-10-2001
Stocking Location	Inland-LaCrosse

Since Trane has a policy of continuous product and product data improvement, it reserves the right to change design and specifications without notice.