



# UniTrane<sup>®</sup> Fan-Coil

---

**Air Terminal Devices**

**Horizontal, Vertical, and Low Vertical  
Sizes 02-12**

**Basic Series Fan-Coil, Sizes 04-08**





## It isn't just a fan and a coil...

The Trane Company has redesigned the traditional fan-coil to lead the industry in:

- indoor air quality (IAQ) features
- easy installation and maintenance
- high quality and durability
- advanced controls

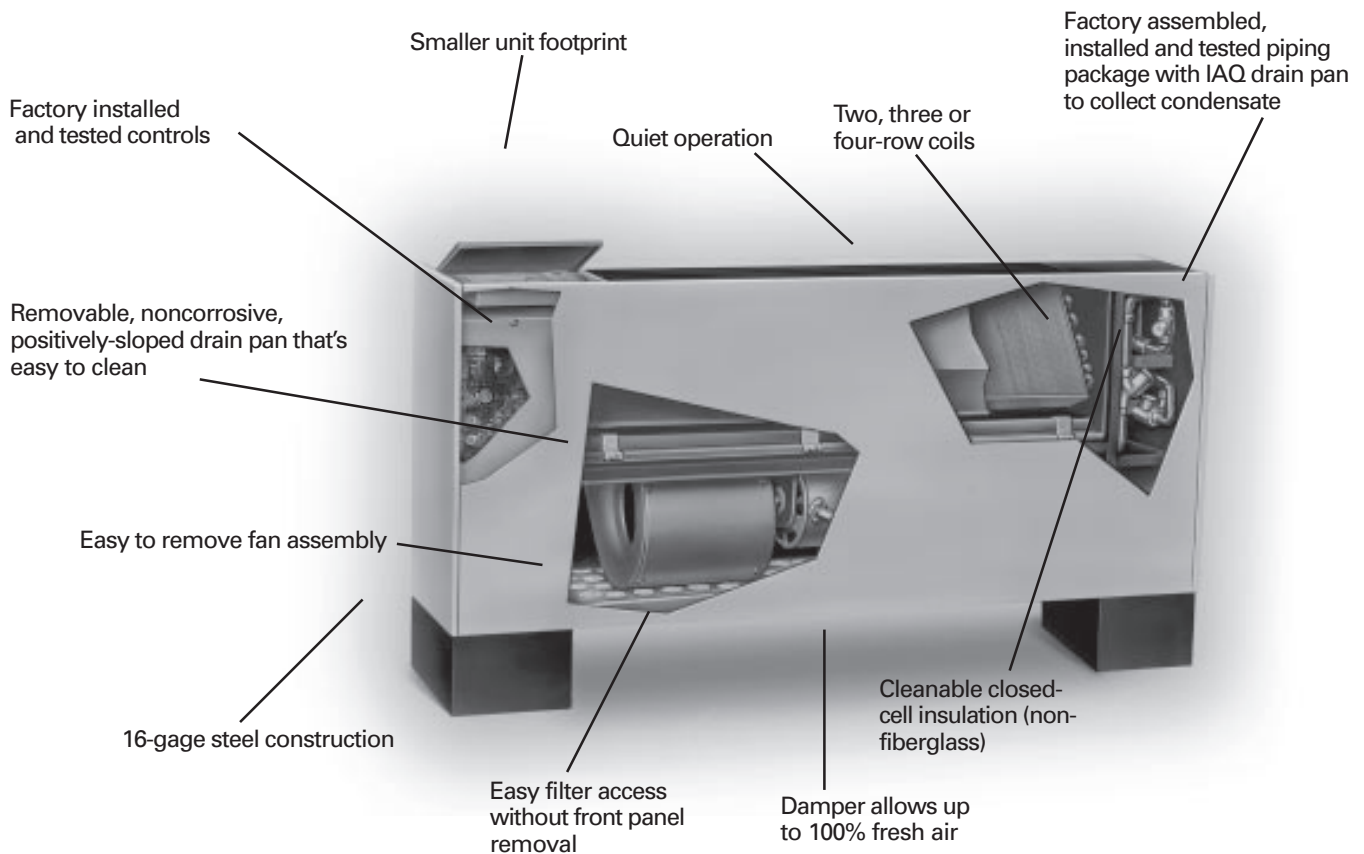

# Contents

---

	Basic	UniTrane
<b>Introduction</b>		2
<b>Features and Benefits</b>	64	4
<b>Selection Procedure</b>	65	5
Model Number Description	65	5
<b>General Data</b>	66	12
<b>Performance Data</b>	67	18
Two-Pipe Coils	67	19
Four-Pipe Coils	68	22
Hot Water Reheat Coils		25
Steam Reheat Coils		28
<b>Controls</b>	69	31
<b>Electrical Data</b>	70	39
<b>Dimensions and Weights</b>	72	42
<b>Mechanical Specifications</b>	75	58
Options		60



# Features and Benefits

The UniTrane® fan-coil meets the standards of today's market, as well as the anticipated needs of tomorrow's market. The tradition that company founder Reuben Trane began in the 1930s continues with the latest generation of fan-coils from The Trane Company.

The UniTrane® fan-coil is the leader in these key areas:

- Indoor Air Quality (IAQ)
- Controls
- Flexibility
- Quality
- Serviceability

Today's HVAC market is concerned with issues such as indoor air quality (IAQ) and CFCs that demand a change in HVAC products. In addition, renovation has overtaken new construction in the fan-coil market—demanding a design that caters to renovation issues. Trane is concerned with these issues, too. That's why we designed the UniTrane fan-coil as an integral part of the company's system solutions with standard IAQ-related features that fully comply with ASHRAE 62.

## IAQ Design

- Closed-cell insulation is standard on all units to help prevent fiberglass in the airstream.
- The main and auxiliary drain pans are constructed of a noncorrosive engineered plastic (ABS and CyColac T).
- The main and auxiliary drain pans are positively sloped in every plane to assure proper drainage and help maximize protection from microbial growth.
- The drain pans are removable for cleaning.
- Easy filter access encourages frequent changing.
- The auto-economizer damper option allows free cooling and ventilation to help comply with ASHRAE 62—and save energy and operating costs.
- UniTrane fan-coils have a blow-thru design. Low vertical units are draw-thru.

## Controls

- All controls are factory-mounted and tested to minimize field setup.

- Controls are wired with a 24 VAC transformer to keep only a single source power connection requirement to the unit.
- All wall-mounted zone sensors require only low voltage control wiring from the device to the unit control box. (No line voltage.)
- The Tracer® controls family introduces the latest in control technology with Tracer ZN010, ZN510, and ZN520 controllers.
- The controller automatically determines the unit's correct operating mode (heat/cool) by utilizing a proportional/integral (PI) control algorithm to maintain the space temperature at the active setpoint, allowing total comfort control.
- Entering water temperature sampling eliminates the need for inefficient bleedlines to sense automatic changeover on two-pipe changeover units.
- The random start-up feature helps reduce electrical demand peaks by randomly staggering multiple units at start-up.
- Occupied/unoccupied operation allows the controller to utilize unoccupied temperature setpoints for energy savings.
- Warm-up and cool-down energy features are standard with Trane controls.
- Continuous fan or fan cycling is available with Tracer ZN010 or ZN510.
- Monitor unit operation using Tracer® Summit building management system with Tracer ZN510 or ZN520.
- To customize unit control, Tracer Summit or Rover™ software will allow field modification of Tracer ZN510 and ZN520 default settings. Tracer ZN010 uses Rover to field modify default settings.
- Maximize fan-coil system efficiency with free cooling economizers and modulating valves on units with Tracer ZN520.

## Flexibility

- Two, three, and four-row coils allow greater design flexibility in two and four-pipe systems.
- One-row steam or hot water reheat coils for dehumidification on units with ZN520 controls.

- Fan motors are available for either high static (0.4-inch external static pressure) or free discharge applications.
- Piping is factory assembled, mounted and tested. Units are also available without piping. Reheat coil piping is available on 2-pipe units with hot water reheat coils and either a fan speed switch or Tracer ZN520.
- Factory piping options include interconnecting piping, control valves, and end valves. Deluxe piping also has unions and a strainer.
- Control options range from a simple fan speed switch to a DDC controller that can tie into a Tracer Summit® building automation system.
- An 8-inch (20 cm) extended end pocket is an available option on the piping end of cabinet style units.
- Slope-top vertical cabinet units are also available for school and dormitory applications to prevent items from being placed on top of the units.

## Quality

- Coils and piping packages are air and leak-tested before mounting on the fan-coil.
- Coil piping connections are also air and leak-tested after mounting on the unit.
- All control end devices and moving components (fans and motors) are computer-tested after units are complete.

## Serviceability

- Filters are easily removable and changed without removing the front panel on vertical cabinet units.
- Motors are easy to disconnect from the fan board, allowing easy service.
- The main and auxiliary drain pans are easily removable and wipe clean with a wet cloth.
- The manual output test function is an invaluable troubleshooting tool. By simply pressing the test button on the Tracer® ZN510, ZN520, or ZN010; service personnel can manually exercise outputs in a pre-defined sequence.



# Selection Procedure

# Model Number Description

## UniTrane Fan-Coil Model Number Description

Following is a complete description of the fan-coil model number. Each digit in the model number has a corresponding code that identifies specific unit options.

**FC B B 020 1 C P0 A 0 G 1 0 A A 2 M 000 0 0 1 0 0 0 A A 000 000 0 0 0 0 A 0 0**  
**1 5 10 15 20 25 30 35 40 44**

### Digits 1, 2 — Unit Type

FC = Fan-Coil

### Digit 3 — Cabinet Type

A = Vertical Concealed  
 B = Vertical Cabinet  
 C = Horizontal Concealed  
 D = Horizontal Cabinet  
 E = Horizontal Recessed  
 H = Vertical Recessed  
 J = Vertical Cabinet Slope Top  
 K = Low Vertical Concealed  
 L = Low Vertical Cabinet

### Digit 4 — Development Sequence “B”

### Digits 5, 6, 7 — Unit Size

020 040 080  
 030 060 100  
 120

### Digit 8 — Unit Voltage

1 = 115/60/1    8 = 110-120/50/1  
 2 = 208/60/1    9 = 220-240/50/1  
 3 = 277/60/1  
 4 = 230/60/1

### Digit 9 — Piping System/Placement

A = No piping, RH, No Auxiliary Drain Pan  
 B = No piping, LH, No Auxiliary Drain Pan  
 C = No piping, RH, with Auxiliary Drain Pan  
 D = No piping, LH, with Auxiliary Drain Pan  
 E = No piping, RH, No Auxiliary Drain Pan, Extended End Pocket  
 F = No piping, LH, No Auxiliary Drain Pan, Extended End Pocket  
 G = No piping, RH, with Auxiliary Drain Pan, Extended End Pocket  
 H = No piping, LH, with Auxiliary Drain Pan, Extended End Pocket  
 J = With piping package, RH  
 K = With piping package, LH  
 L = With piping package, RH, Extended End Pocket  
 M = With piping package, LH, Extended End Pocket

### Digits 10, 11 — Design Sequence “P0”

#### Digit 12 — Inlets

A = Front Toe Space  
 B = Front Bar Grille  
 C = Front Stamped Louver  
 D = Bottom Stamped Louver  
 E = Bottom Toe Space  
 F = Back Duct Collar  
 G = Back Open Return  
 H = Back Stamped Louver

#### Digit 13 — Fresh Air Damper

0 = None  
 A = Manual, Bottom Opening  
 B = Manual, Back Opening  
 C = Manual, Top Opening  
 D = Auto, 2-Position, Bottom Opening  
 E = Auto, 2-Position, Back Opening  
 F = Auto, 2-Position, Top Opening  
 G = Auto, Economizer, Bottom Opening  
 H = Auto, Economizer, Back Opening  
 J = Auto, Economizer, Top Opening  
 K = No Damper, Bottom Opening  
 L = No Damper, Back Opening  
 M = No Damper, Top Opening

#### Digit 14 — Outlets

A = Front Duct Collar  
 B = Front Bar Grille  
 C = Front Stamped Louver  
 D = Front Quad Grille  
 G = Top Quad Grille  
 H = Top Bar Grille  
 J = Top Duct Collar

#### Digit 15 — Color

0 = No Paint (Concealed Units Only)  
 1 = Deluxe Beige    4 = Driftwood Grey  
 2 = Soft Dove    5 = Stone Grey  
 3 = Cameo White    6 = Rose Mauve

#### Digit 16 — Tamperproof Locks/Leveling Feet

0 = None  
 B = Keylock Access Door  
 C = Keylock Panel and Access Door  
 D = Leveling Feet  
 F = Keylock Access Door with Leveling Feet  
 G = Keylock Panel and Access Door with Leveling Feet

#### Digit 17 — Motor

A = Free Discharge  
 B = High Static

### Digit 18 — Coil

A = 2 Row Cooling/Heating  
 B = 3 Row Cooling/Heating  
 C = 4 Row Cooling/Heating  
 D = 2 Row Cooling/1 Row Heating  
 E = 2 Row Cooling/2 Row Heating  
 F = 3 Row Cooling/1 Row Heating  
 G = 2 Row Cooling Only  
 H = 3 Row Cooling Only  
 J = 4 Row Cooling Only  
 K = 2 Row Cooling/Heating with Electric Heat  
 L = 3 Row Cooling/Heating with Electric Heat  
 M = 4 Row Cooling/Heating with Electric Heat  
 P = 2 Row Cooling/Heating with 1 Row Heating  
 Q = 2 Row Cooling/Heating with 2 Row Heating  
 R = 3 Row Cooling/Heating with 1 Row Heating

### Digit 19 — Coil Series

2 = 144 FPF

### Digit 20 — Coil Air Vent

A = Automatic Air Vent  
 M = Manual Air Vent

### Digits 21, 22, 23 — Electric Heat kW — ( ) = 208V Derate

000 = No Electric Heat  
 010 = 1.0 kW (0.75 kW)  
 015 = 1.5 kW (1.1 kW)  
 020 = 2.0 kW (1.5 kW)  
 025 = 2.5 kW (1.9 kW)  
 030 = 3.0 kW (2.3 kW)  
 040 = 4.0 kW (3.0 kW)  
 050 = 5.0 kW (3.8 kW)  
 060 = 6.0 kW (4.5 kW)  
 070 = 7.0 kW (5.3 kW)  
 080 = 8.0 kW (6.0 kW)  
 100 = 10.0 kW

### Digit 24 — Reheat Coil

0 = None    B = Hot Water Coil  
 A = Steam Coil

### Digit 25 — Disconnect Switch

0 = None  
 D = Disconnect Switch



# Selection Procedure

# Model Number Description

### Digit 26 — Filter

- 0 = None
- 1 = 1" Throwaway Filter
- 2 = 1" Throwaway Pleated Media Filter
- 3 = 1" Throwaway + (1) Extra
- 4 = 1" Throwaway Pleated Media + (1) Extra
- 5 = 1" Throwaway + (2) Extras
- 6 = 1" Throwaway Pleated Media + (2) Extras
- 7 = 1" Throwaway + (3) Extras
- 8 = 1" Throwaway Pleated Media + (3) Extras

### Digit 27 — Main Control Valve

- 0 = None
- A = 2-Way, 2-Position, NO (30 psig)
- B = 3-Way, 2-Position, NO (28 psig)
- C = 2-Way, 2-Position, NC (30 psig)
- D = 3-Way, 2-Position, NC (20 psig)
- E = 2-Way, 2-Position, NO (50 psig)
- F = 3-Way, 2-Position, NO (28 psig)
- G = 2-Way, 2-Position, NC (50 psig)
- H = 3-Way, 2-Position, NC (28 psig)
- J = 2-Way, Modulating, 0.7 Cv (50 psig)\*
- K = 3-Way, Modulating, 0.7 Cv (50 psig)\*
- L = 2-Way, Modulating, 1.5 Cv (50 psig)\*
- M = 3-Way, Modulating, 1.5 Cv (50 psig)\*
- N = 2-Way, Modulating, 2.5 Cv (50 psig)\*
- P = 3-Way, Modulating, 2.5 Cv (50 psig)\*
- Q = 2-Way, Modulating, 4.0 Cv (50 psig)\*
- R = 3-Way, Modulating, 4.0 Cv (50 psig)\*
- X = Field-supplied, NO
- Y = Field-supplied, NC
- Z = Field-supplied 3-Wire Modulating

### Digit 28 — Auxiliary Control Valve

- 0 = None
- A = 2-Way, 2-Position, NO (30 psig)
- B = 3-Way, 2-Position, NC (28 psig)
- C = 2-Way, 2-Position, NC (30 psig)
- D = 3-Way, 2-Position, NC (20 psig)
- E = 2-Way, 2-Position, NO (50 psig)
- F = 3-Way, 2-Position, NO (28 psig)
- G = 2-Way, 2-Position, NC (50 psig)
- H = 3-Way, 2-Position, NC (28 psig)
- J = 2-Way, Modulating, 0.7 Cv (50 psig)
- K = 3-Way, Modulating, 0.7 Cv (50 psig)
- L = 2-Way, Modulating, 1.5 Cv (50 psig)
- M = 3-Way, Modulating, 1.5 Cv (50 psig)
- N = 2-Way, Modulating, 2.5 Cv (50 psig)
- P = 3-Way, Modulating, 2.5 Cv (50 psig)
- Q = 2-Way, Modulating, 4.0 Cv (50 psig)
- R = 3-Way, Modulating, 4.0 Cv (50 psig)
- X = Field-supplied, NO

- Y = Field-supplied, NC
- Z = Field-supplied 3-Wire Modulating

### Digit 29 — Piping Packages

- 0 = None
- A = Basic Ball Valve Supply and Return
- B = Basic Ball Valve Supply/Manual Circuit Setter
- C = Basic Ball Valve Supply and Return with Auto Circuit Setter
- D = Deluxe Ball Valve Supply and Return
- E = Deluxe Ball Valve Supply/Manual Circuit Setter
- F = Deluxe Ball Valve Supply and Return with Auto Circuit Setter

### Digit 30 — Control Type

- A = Fan Mode Switch
- E = Tracer ZN010
- F = Tracer ZN510
- G = Tracer ZN520

### Digit 31 — Control Option

- D = Unit Mounted Fan Mode Switch
- K = Wall Mounted Fan Mode Switch
- V = Unit Mounted Fan Speed Switch w/ Setpoint Dial Zone Sensor
- W = Wall Mounted Fan Speed Switch w/ Setpoint Dial Zone Sensor
- X = Unit Mounted Fan Speed Switch w/ Wall Mounted Setpoint Dial Zone Sensor
- Y = Unit Mounted Fan Speed Switch & Wall Mounted Setpoint Dial W/ Comm.
- Z = Unit Mounted Fan Speed Switch, On/Cancel, Setpoint Dial W/ Comm.
- 1 = Wall Mounted On/Cancel W/ Comm.
- 2 = Wall Mounted Fan Speed Switch, Setpoint Dial, On/Cancel W/ Comm.

### Digits 32, 33, 34 — Future Control Functions

### Digit 35 — Control Function #3

- 0 = None
- 1 = Occ/Unocc Control
- 2 = Condensate Overflow Detection
- 3 = Occ/Unocc & Condensate Overflow

### Digit 36 — Control Function #4

- 0 = None
- 1 = Smoke Input
- 2 = Low Temperature Detection
- 3 = Smoke Input & Low Limit Sensor

### Digits 37, 38 — Future Control Functions

### Digit 39 — Projection Panels and Falsebacks

- 0 = None
- A = 5/8" Standard Recessed Panel (Vertical Recessed Units Only)
- B = 2" Projection Panel
- C = 2.5" Projection Panel
- D = 3" Projection Panel
- E = 3.5" Projection Panel
- F = 4" Projection Panel
- G = 4.5" Projection Panel
- H = 5" Projection Panel
- J = 5.5" Projection Panel
- K = 6" Projection Panel
- L = 2" Falseback
- M = 3" Falseback
- N = 4" Falseback
- P = 5" Falseback
- Q = 6" Falseback
- R = 7" Falseback
- T = 8" Falseback

### Digit 40 — Main Autoflow Gpm

- |          |         |          |
|----------|---------|----------|
| A = 0.5  | G = 3.0 | N = 7.0  |
| B = 0.75 | H = 3.5 | P = 8.0  |
| C = 1.0  | J = 4.0 | Q = 9.0  |
| D = 1.5  | K = 4.5 | R = 10.0 |
| E = 2.0  | L = 5.0 | T = 11.0 |
| F = 2.5  | M = 6.0 | U = 12.0 |

### Digit 41 — Auxiliary Autoflow Gpm

- |          |         |         |
|----------|---------|---------|
| A = 0.5  | F = 2.5 | L = 5.0 |
| B = 0.75 | G = 3.0 | M = 6.0 |
| C = 1.0  | H = 3.5 | N = 7.0 |
| D = 1.5  | J = 4.0 | P = 8.0 |
| E = 2.0  | K = 4.5 |         |

### Digit 42 — Subbases

- |                |                |  |
|----------------|----------------|--|
| 0 = None       |                |  |
| A = 2" Subbase | D = 5" Subbase |  |
| B = 3" Subbase | E = 6" Subbase |  |
| C = 4" Subbase | F = 7" Subbase |  |

### Digit 43 — Recessed Flange

- 0 = None
- A = Recessed Flange

### Digit 44 — Wall Boxes

- 0 = None
- A = Anodized Wall Box

Note: Not all options are available on all cabinet styles. Contact your local Trane sales representative for more information.

## General Data

## Unit Configurations

### Model A Vertical Concealed

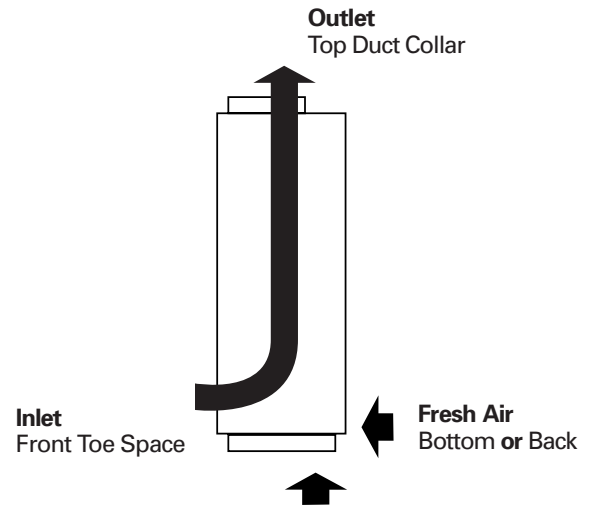
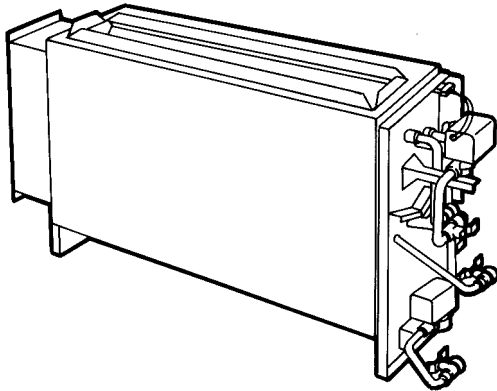

### Model B Vertical Cabinet

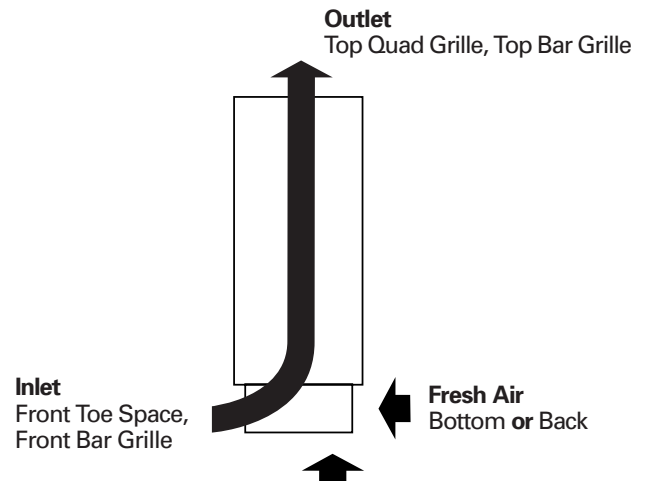
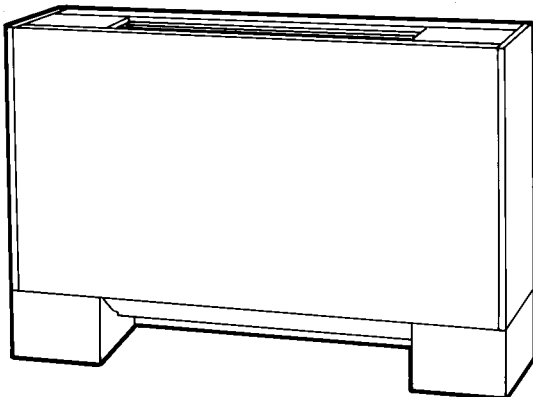

# General Data

# Unit Configurations

## Model C Horizontal Concealed

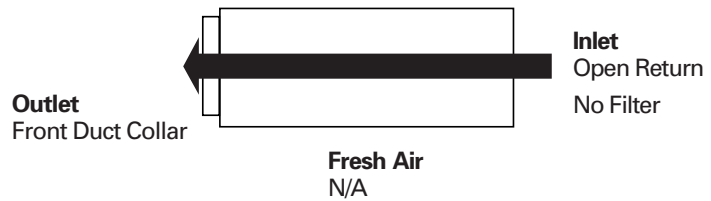
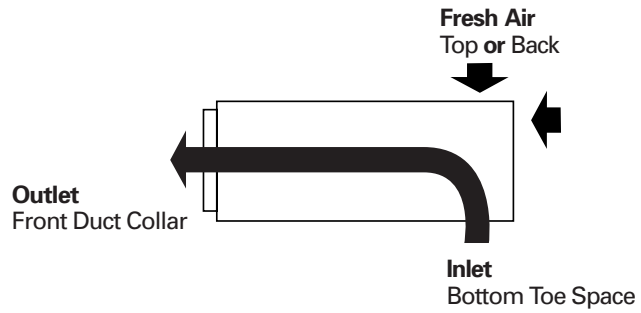
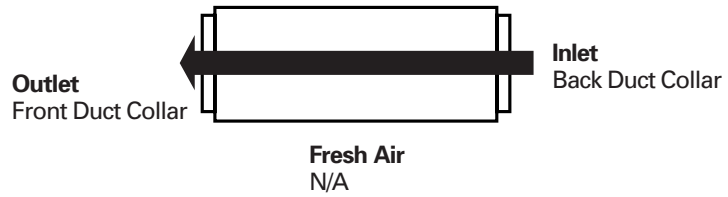
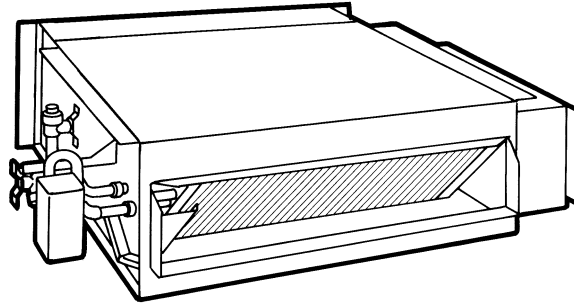

# General Data

# Unit Configurations

## Model D Horizontal Cabinet

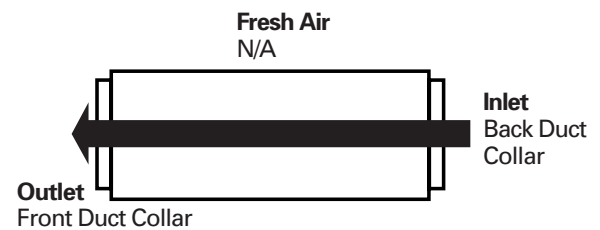
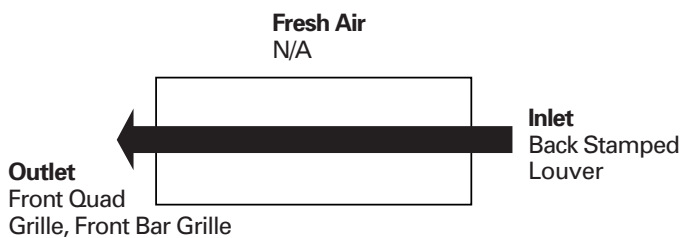
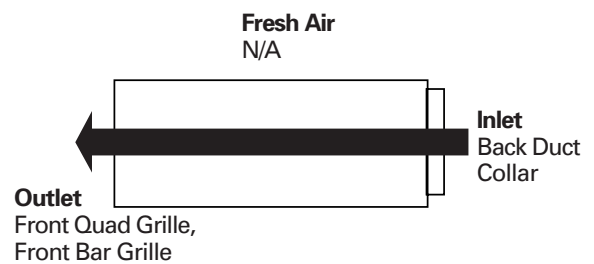
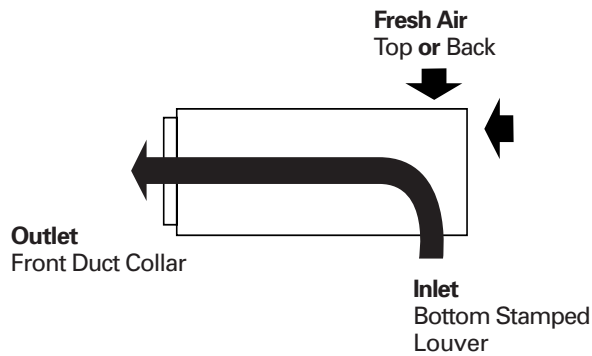
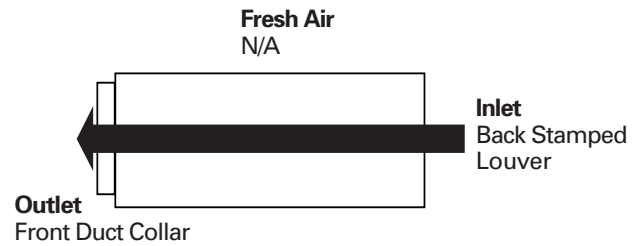
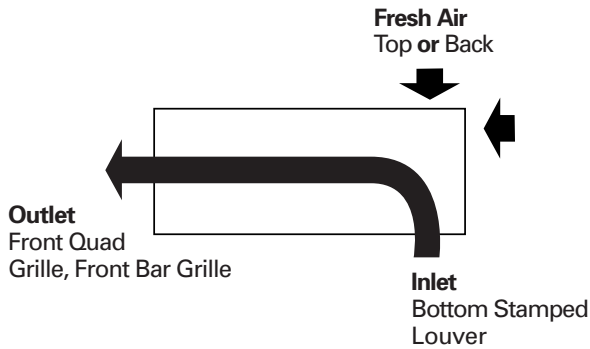
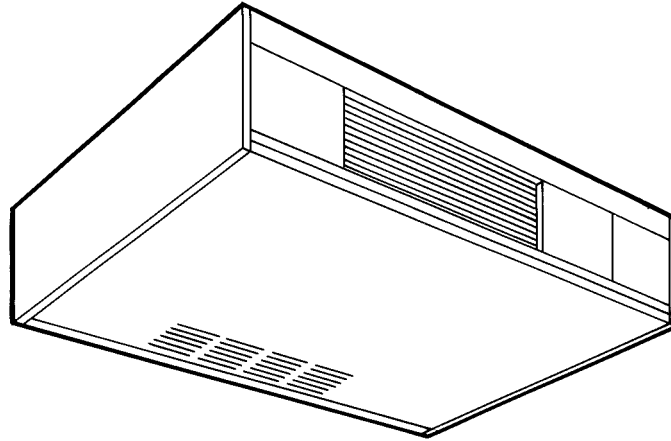

# General Data

# Unit Configurations

## Model E Horizontal Recessed

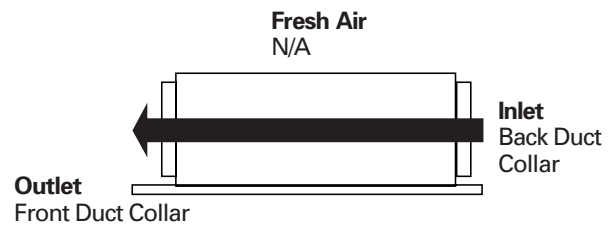
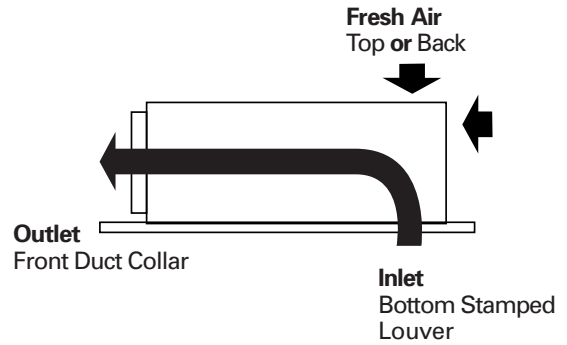
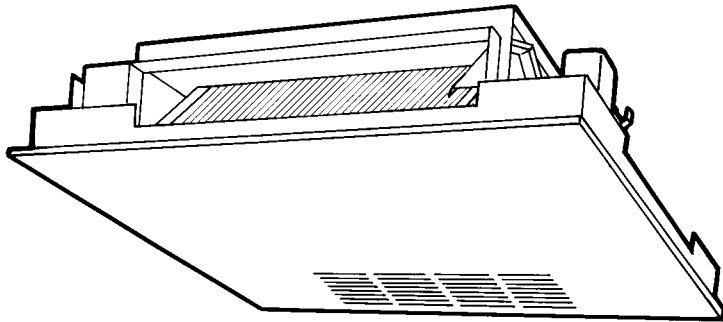

## Model H Vertical Recessed

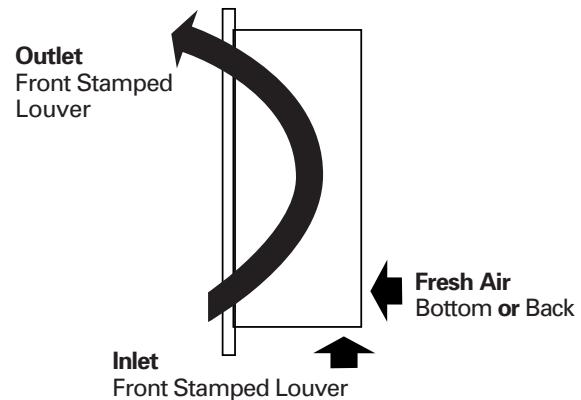
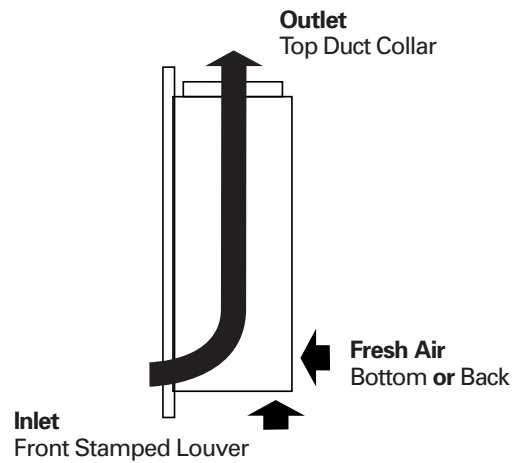
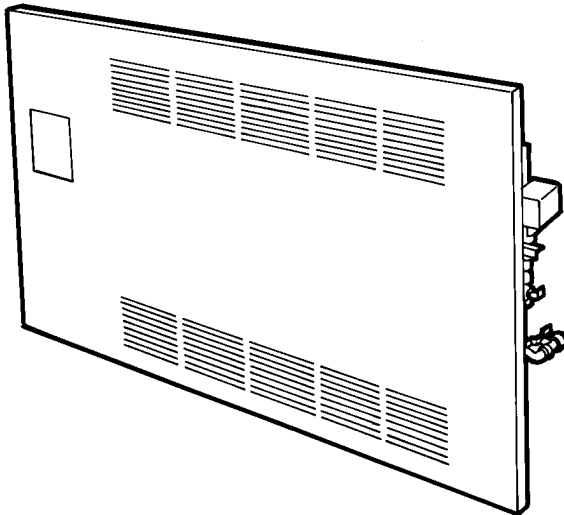

# General Data

# Unit Configurations

**Model J**  
Vertical Cabinet Slope Top

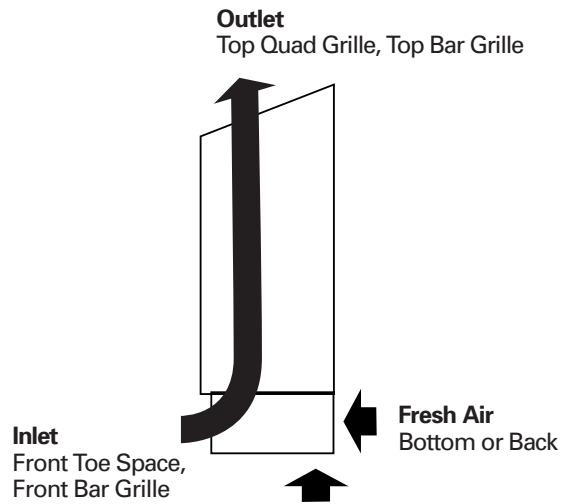
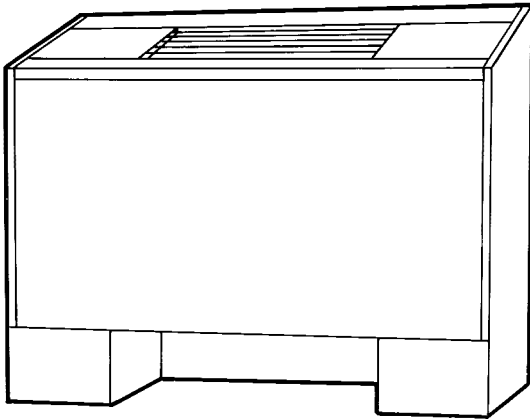

**Model K**  
Low Vertical Concealed

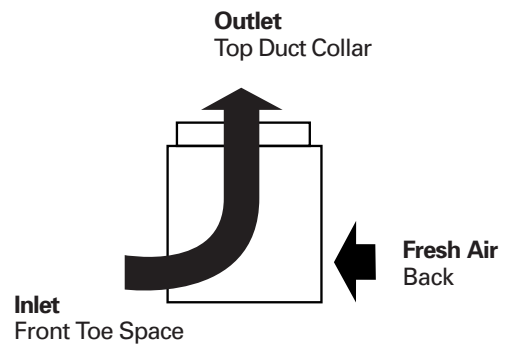
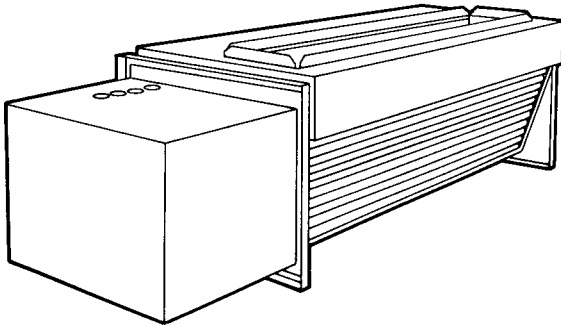

**Model L**  
Low Vertical Cabinet

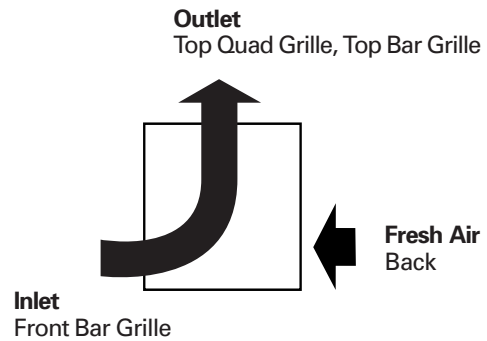
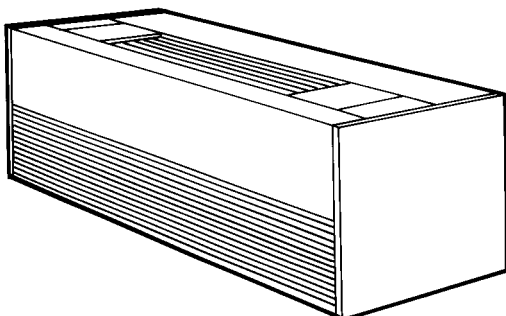



# General Data

**Table GD-1. UniTrane® Fan-Coil General Data**

Unit Size	02	03	04	06	08	10	12
<b>Coil Data</b>							
Face Area — Ft <sup>2</sup> (cm <sup>2</sup> )	0.8 (743)	0.8 (743)	1.1 (1020)	1.6 (1490)	2.1 (1950)	3.2 (2970)	3.2 (2970)
LxDxH — In. (cm)							
2-Row	15x1.7x8 (38x4x20)	15x1.7x8 (38x4x20)	20x1.7x8 (51x4x20)	29.5x1.7x8 (75x4x20)	38x1.7x8 (97x4x20)	57x1.7x8 (145x4x20)	57x1.7x8 (145x4x20)
3-Row	15x2.6x8 (38x7x20)	15x2.6x8 (38x7x20)	20x2.6x8 (51x7x20)	29.5x2.6x8 (75x7x20)	38x2.6x8 (97x7x20)	57x2.6x8 (145x7x20)	57x2.6x8 (145x7x20)
4-Row	15x3.5x8 (38x9x20)	15x3.5x8 (38x9x20)	20x3.5x8 (51x9x20)	29.5x3.5x8 (75x9x20)	38x3.5x8 (97x9x20)	57x3.5x8 (145x9x20)	57x3.5x8 (145x9x20)
Volume — Gal. (Liters)							
1-Row (Heat)	.06 (.23)	.06 (.23)	.08 (.30)	.11 (.42)	.14 (.53)	.21 (.79)	.21 (.79)
2-Row	.12 (.45)	.12 (.45)	.15 (.57)	.22 (.83)	.28 (1.06)	.42 (1.59)	.42 (1.59)
3-Row	.18 (.68)	.18 (.68)	.23 (.87)	.33 (1.25)	.42 (1.59)	.62 (2.35)	.62 (2.35)
4-Row	.24 (.91)	.24 (.91)	.30 (1.14)	.44 (1.67)	.56 (2.12)	.83 (3.14)	.83 (3.14)
Fins/Ft (cm)							
2-Row	144 (4.7)	144 (4.7)	144 (4.7)	144 (4.7)	144 (4.7)	144 (4.7)	144 (4.7)
3-Row	144 (4.7)	144 (4.7)	144 (4.7)	144 (4.7)	144 (4.7)	144 (4.7)	144 (4.7)
4-Row	144 (4.7)	144 (4.7)	144 (4.7)	144 (4.7)	144 (4.7)	144 (4.7)	144 (4.7)
<b>Reheat Coil Data (1-Row)</b>							
<b>Hot Water or Steam</b>							
Face Area — Ft <sup>2</sup> (cm <sup>2</sup> )	0.6 (557)	0.6 (557)	0.8 (743)	1.2 (1120)	1.6 (1490)	2.4 (2230)	2.4 (2230)
LxDxH — In. (cm)	15x1.5x6 (38x4x15)	15x1.5x6 (38x4x15)	20x1.5x6 (51x4x15)	29.5x1.5x6 (75x4x15)	38x1.5x6 (97x4x15)	57x1.5x6 (145x4x15)	57x1.5x6 (145x4x15)
Volume — Gal. (Liters)	.12 (.45)	.12 (.45)	.15 (.57)	.22 (.83)	.28 (1.06)	.42 (1.59)	.42 (1.59)
Fins/Ft (cm)	48 (1.6)	48 (1.6)	48 (1.6)	48 (1.6)	48 (1.6)	48 (1.6)	48 (1.6)
<b>Fan/Motor Data</b>							
Fan Quantity	1	1	1	2	2	3	3
Size — Dia" x Width" (cm)	6.31x4 (16x10)	6.31x6.5 (16x17)	6.31x7.5 (16x19)	6.31x6.5 (16x17)	6.31x7.5 (16x19)	(1) 6.31x7.5 (16x19)	6.31x7.5 (16x19)
Size — Dia" x Width" (cm)						(2) 6.31x6.5 (16x6.5)	
Motor Quantity	1	1	1	1	1	2	2
<b>Filter Data</b>							
<b>1" (cm) TA and PI Media</b>							
Quantity	1	1	1	1	1	1	1
Size — In. (cm)	8 <sup>7</sup> / <sub>8</sub> x 19 <sup>1</sup> / <sub>8</sub> (23x49)	8 <sup>7</sup> / <sub>8</sub> x 19 <sup>1</sup> / <sub>8</sub> (23x49)	8 <sup>7</sup> / <sub>8</sub> x 24 <sup>1</sup> / <sub>8</sub> (23x61)	8 <sup>7</sup> / <sub>8</sub> x 33 <sup>5</sup> / <sub>8</sub> (23x85)	8 <sup>7</sup> / <sub>8</sub> x 42 <sup>1</sup> / <sub>8</sub> (23x107)	8 <sup>7</sup> / <sub>8</sub> x 61 <sup>1</sup> / <sub>8</sub> (23x155)	8 <sup>7</sup> / <sub>8</sub> x 61 <sup>1</sup> / <sub>8</sub> (23x155)
<b>1" Fresh Air Filter (only on cabinet styles D, E, and H with bottom return and fresh air opening)</b>							
Quantity	1	1	1	1	1	1	1
Size — In. (cm)	5 <sup>1</sup> / <sub>2</sub> x 19 <sup>1</sup> / <sub>8</sub> (14 x 49)	5 <sup>1</sup> / <sub>2</sub> x 19 <sup>1</sup> / <sub>8</sub> (14 x 61)	5 <sup>1</sup> / <sub>2</sub> x 24 <sup>1</sup> / <sub>8</sub> (14 x 85)	5 <sup>1</sup> / <sub>2</sub> x 33 <sup>5</sup> / <sub>8</sub> (14 x 107)	5 <sup>1</sup> / <sub>2</sub> x 42 <sup>1</sup> / <sub>8</sub> (14 x 156)	5 <sup>1</sup> / <sub>2</sub> x 61 <sup>1</sup> / <sub>8</sub> (14 x 156)	5 <sup>1</sup> / <sub>2</sub> x 61 <sup>1</sup> / <sub>8</sub>

**Table GD-2. Low Vertical Fan-Coil General Data**

Unit Size	03	04	06
<b>Coil Data</b>			
Face Area — Ft <sup>2</sup> (cm <sup>2</sup> )	1.1 (1020)	1.6 (1490)	2.1 (1950)
LxDxH — In. (cm)			
2-Row	20x1.7x8 (51x4x20)	29.5x1.7x8 (75x4x20)	38x1.7x8 (97x4x20)
3-Row	20x2.6x8 (51x7x20)	29.5x2.6x8 (75x7x20)	38x2.6x8 (97x7x20)
Volume — Gal. (Liters)			
1-Row (Heat)	.08 (.30)	.11 (.42)	.14 (.53)
2-Row	.15 (.57)	.22 (.83)	.28 (1.06)
3-Row	.23 (.87)	.33 (1.25)	.42 (1.59)
Fins/Ft			
2-Row	144 (4.7)	144 (4.7)	144 (4.7)
3-Row	144 (4.7)	144 (4.7)	144 (4.7)
<b>Fan/Motor Data</b>			
Fan Quantity	1	1	1
Size — Dia" x Width" (cm)	5x23 (13x59)	5x32 (13x83)	5x41 (13x105)
Motor Quantity	1	1	1
<b>Filter Data</b>			
<b>1" (2.5 cm) TA</b>			
Quantity	1	1	1
Size — In. (cm)	8 <sup>7</sup> / <sub>8</sub> x24 <sup>1</sup> / <sub>8</sub> (23x61)	8 <sup>7</sup> / <sub>8</sub> x33 <sup>5</sup> / <sub>8</sub> (23x85)	8 <sup>7</sup> / <sub>8</sub> x 42 <sup>1</sup> / <sub>8</sub> (23x107)

# General Data

**Table GD-3. Fan-Coil Air Flow**

FC	Motor Coil	FD 0.05	ESP			
			High Static			
			0.1	0.2	0.3	0.4
02	2R144	240	330	300	280	250
	3R144	230	330	300	270	240
	4R144	200	300	270	250	220
03	2R144	320	410	390	350	320
	3R144	310	400	360	330	290
	4R144	280	370	340	300	270
04	2R144	390	450	410	380	340
	3R144	370	550	510	470	430
	4R144	340	510	480	440	400
06	2R144	610	760	700	650	590
	3R144	610	890	830	770	710
	4R144	560	820	760	710	660
08	2R144	800	1020	960	890	820
	3R144	730	1000	930	870	800
	4R144	680	940	870	810	750
10	2R144	980	1260	1180	1090	1010
	3R144	1000	1400	1310	1210	1120
	4R144	930	1300	1220	1130	1040
12	2R144	1110	1430	1330	1240	1140
	3R144	1080	1520	1420	1330	1220
	4R144	1000	1430	1340	1240	1150

Note: This data is based on horizontal concealed model only, with duct inlet, duct outlet and no filter, dry coil, all voltages except 208 V.

## General Data

## Piping Packages

### Factory-Installed Piping Packages

UniTrane® fan-coils have standard piping packages available as a factory built and installed option. Piping package options are also available for the hot water reheat coil on two-pipe units equipped with either a fan speed switch or Tracer® ZN520 controller. Factory built assures all piping packages are fully tested under water for leaks and are built within strict tolerances. Factory-installed means that chilled and hot water pipes are the only field connections required. The installer doesn't have to sweat connect piping packages onto coil connections in a tight end pocket. Field connections are brought to a point near the exterior of the unit for easy access. All piping and components are located to allow condensate to drain into the auxiliary drain pan. Insulation of the factory piping package is not required. However, all field connections should be insulated to prevent condensation from missing the auxiliary drain pan.

### Piping Package Components

UniTrane piping packages consist of a variety of components for each applica-

tion. The following section provides a detailed description of each of the piping components. Following this section are additional illustrations and specifications.

### Piping System/Placement

Factory piping systems are available for either two or four-pipe systems with right or left hand connections. Four-pipe systems have both the heating and cooling connections on the same side of the unit. A simple coil connection (a unit without a piping package) is also available in either a right or left hand configuration for those applications requiring field piping.

### Interconnecting Piping

Interconnecting piping refers to the copper piping which is attached to the coil connections and to which all other components (control valves, end valves, etc.) are attached. Piping is 1/2" nominal OD copper. Two-pipe piping extends near the unit exterior to one inlet and one outlet connection. Four-pipe units have two sets of piping that extend near the unit exterior — one inlet and one outlet each for both chilled and hot water. A label clearly identifies chilled and hot water connection points on every unit.

### Deluxe or Basic Piping Package

The basic piping package includes only the main components of the piping package: interconnecting piping, control valve option, and end valves.

The deluxe piping package also includes a strainer on the entering water pipe and unions at the coil connections along with the basic components. The strainer body is cast brass construction, with a stainless steel mesh strainer that is easily removed for cleaning. The unions are forged brass construction and close with a minimum amount of effort.

### End Valves

Each piping package includes a ball valve for the entering water pipe and one of the following end valves on the leaving water pipe: ball valve, manual circuit setter, or an auto circuit setter. These valves serve as the field connection points on all UniTrane piping packages.

### • Ball Valves

Ball valves, also known as stop or end valves, allow the unit to be cut off for service purposes. These valves have a two-inch handle that rotates 90° to a fully open position. The valve body is cast brass, and the ball is polished brass with a Teflon seat. Ball valves are available as end valves on both the entering and leaving water pipes.

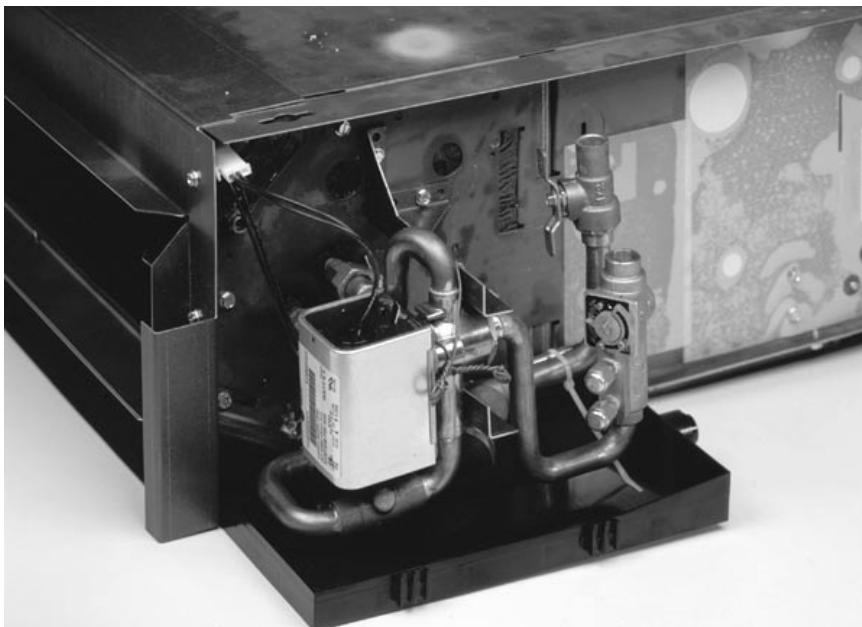

*Factory-installed and tested piping package. Two-pipe deluxe package with manual circuit setter is shown on a horizontal concealed unit.*

## General Data

## Piping Packages

### Manual Circuit Setter

In lieu of a ball valve on the leaving water pipe, a manual circuit setter, also known as a manual flow control valve, acts as both a flow setting device and a stop valve. This valve allows water flow through the fan-coil unit to be set quickly and accurately.

The manual circuit setter includes Schrader ports in the valve body. These ports are used to measure the pressure drop across the valve. This pressure drop can be compared to factory supplied curves that relate the pressure drop to a specific flow rate. This valve also has a memory stop so the correct setting can be found quickly.

### Auto Circuit Setter

An auto circuit setter is an automatic flow control device available on the leaving water pipe. The auto circuit setter includes a cartridge within the valve body that is sized to allow a specific flow rate through the coil. This valve sets flow through the coil without any action required by a system piping balancer. The auto circuit setter is available on the leaving water pipe with a ball valve.

The auto circuit setter also includes two P/T's plugs in the valve body to allow

measurement of the pressure drop temperature through the valve.

### Control Valves

Piping packages are available with or without control valves. All control valve options are factory mounted and wired to the UniTrane® fan-coil controls.

#### • Two-Way/Two-Position Valves

These valves will either fully open or close in response to a 24VAC signal from the Trane controller. Main control valves are direct-acting valves, while the auxiliary valves are reverse-acting. All control valves are factory mounted in the leaving water pipe downstream of the coil. Some means of relieving pump head pressure should be accounted for when two-way valves are selected. Normally open or normally closed valves are available.

#### • Three-Way/Two-Position Valves

These valves will either allow full water flow through the coil or divert the flow through a bypass line. The valves respond to a 24VAC signal from the Trane controller. Main control valves are direct acting valves, while the auxiliary valves are reverse-acting. All three-way valve packages include a balance fitting

in the bypass line to allow flow balancing in the bypass position. Three-way valves are factory mounted in the leaving water pipe downstream of the coil. Normally open or normally closed valves are available.

#### • Two-Way Modulating Valves

These valves modulate the water flow through the coil in response to a signal from the Trane controller. All modulating valves are three-wire floating point equal %age valves. The modulating valves are factory mounted in the leaving water pipe downstream of the coil.

#### • Three-Way Modulating Valves

These valves modulate the water flow through the coil in response to a signal. Three-way valves allow water that is directed through the coil to mix with water that is directed through the bypass line. This mixture exits through the leaving water pipe. All modulating valves are three-wire floating point equal %age valves. The modulating valves are factory mounted in the leaving water pipe downstream of the coil.

# General Data

# Piping Packages

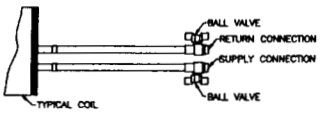
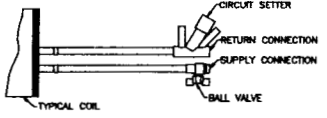
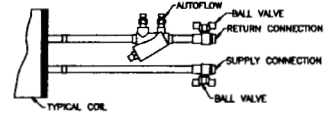
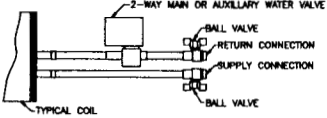
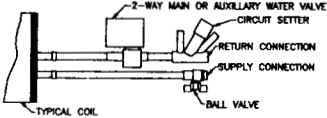
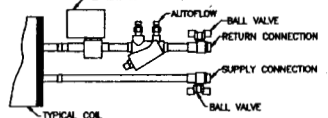
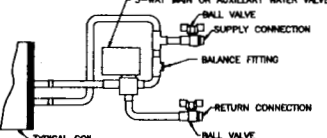
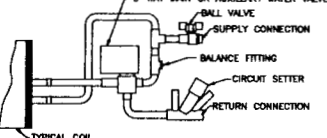
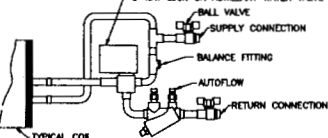
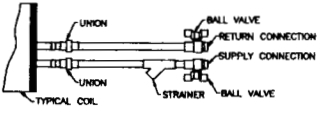
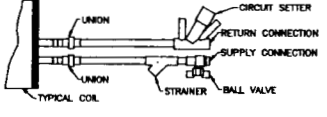
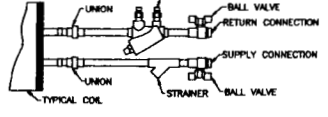
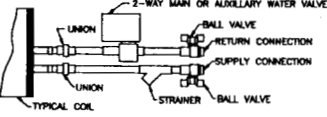
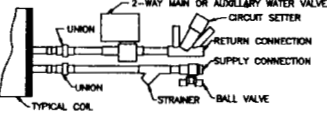
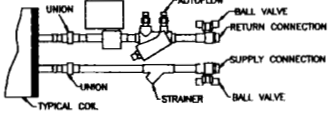
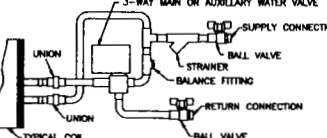
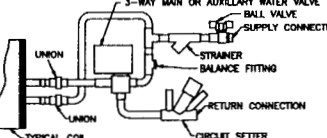
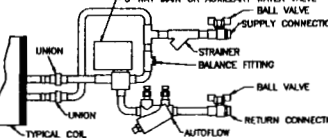
Digits 27,28 Main/Aux. Control Valve BASIC	Digit 29		
	Basic (A)	Circuit Setter (B)	Automatic Circuit Setter (C)
<b>None</b> 0			
<b>2-Way</b> A, C, E, G, J, L, N, Q			
<b>3-Way</b> B, D, F, H, K, M, P, R			
<b>DELUXE</b>	<b>(D)</b>	<b>(E)</b>	<b>(F)</b>
<b>None</b> 0			
<b>2-Way</b> A, C, E, G, J, L, N, Q			
<b>3-Way</b> B, D, F, H, K, M, P, R			

# General Data

## Selecting the Correct Modulating Valve Size

Modulating valves are available in any of four port sizes. These four port sizes relate to a Cv of 0.7, 1.5, 2.5 or 4.0, which is the coefficient of flow. The coefficient of flow is defined as the volume of water flow through a control valve in the fully open position with a 1 psig (6.895 kPa) differential across the valve. It is calculated using the following formula:

$$Cv = Q/\text{Square root } \Delta P$$

where:

Cv = flow coefficient

Q = flow rate (Gpm)

$\Delta P$  = pressure drop across the valve or coil (psig).

For good control, the valve Cv should be approximately equal to the Cv of the water coil.

### Modulating Valve Selection Example

Assume a size 06 fan-coil is selected to operate at the following conditions:

Vertical Cabinet Fan-Coil

Entering water temperature = 45 F (7 C)

Leaving water temperature = 55 F (13 C)

EAT conditions = 80/67.

The coil is selected as a four-row coil.

Select the best modulating valve size for this unit.

1

Find the  $\Delta P$  across the water coil. Refer to the ARI performance table to determine the  $\Delta P$  across the water coil (or use TOPSS™ selection program). The water pressure drop is found to be 7.0' (20.9 kPa) of water at a flow rate of 3.74 gpm. This converts to a pressure drop of 3.03 psig (1.0 feet of water = 0.4328 psig.)

2

Calculate the Cv of the water coil.

$$Cv = \text{Gpm}/\text{Square root } \Delta P.$$

$$Cv = 3.74/\text{Square root } 3.03$$

$$Cv = 2.15$$

Therefore, the valve with the Cv of 2.5 should be selected since it has the Cv which is closest to the Cv of the water coil. The following tables illustrate possible valve selections at ARI conditions for horizontal concealed units with a high static motor and vertical cabinet units with a free discharge motor.

**Note:** Do not use these tables for any applications other than vertical cabinet or horizontal concealed units at ARI conditions.

**Table GD-1. Modulating Valve Selections for Horizontal Concealed Units**

Unit Size	Horizontal Concealed (High Static Motor)				
	Coil	Gpm (L/s)	Coil WPD (kPa)	Coil Cv	Valve Cv
02	2-Row	1.29 (0.08)	8.8 (26.3)	0.66	0.7
	3-Row	1.80 (0.11)	23.9 (71.3)	0.56	0.7
	4-Row	1.84 (0.12)	6.1 (18.3)	1.13	1.5
03	2-Row	1.58 (0.10)	14.1 (42.2)	0.64	0.7
	3-Row	1.86 (0.12)	5.4 (16.1)	1.22	1.5
	4-Row	2.26 (0.14)	9.7 (28.9)	1.10	1.5
04	2-Row	1.90 (0.12)	4.6 (13.7)	1.35	1.5
	3-Row	2.94 (0.19)	13.9 (41.5)	1.20	1.5
	4-Row	3.35 (0.21)	22.3 (66.7)	1.08	0.7
06	2-Row	3.32 (0.21)	15.3 (45.6)	1.29	1.5
	3-Row	4.24 (0.27)	7.5 (22.3)	2.35	2.5
	4-Row	4.99 (0.31)	11.9 (35.6)	2.20	2.5
08	2-Row	3.90 (0.25)	5.7 (16.9)	2.48	2.5
	3-Row	5.13 (0.32)	11.8 (35.2)	2.27	2.5
	4-Row	5.68 (0.36)	16.9 (50.6)	2.10	2.5
10	2-Row	5.23 (0.33)	10.8 (32.2)	2.42	2.5
	3-Row	7.14 (0.45)	24.2 (72.3)	2.21	2.5
	4-Row	7.63 (0.48)	32.8 (98.1)	2.03	2.5
12	2-Row	6.35 (0.40)	16.6 (49.5)	2.37	2.5
	3-Row	7.98 (0.50)	18.5 (55.3)	2.82	2.5
	4-Row	9.47 (0.60)	25.2 (75.4)	2.87	2.5

**Table GD-2. Modulating Valve Selections for Vertical Cabinet Units**

Unit Size	Vertical Cabinet (Free Discharge Motor)				
	Coil	Gpm (L/s)	Coil WPD (kPa)	Coil Cv	Valve Cv
02	2-Row	1.04 (0.07)	6.1 (18.2)	0.64	0.7
	3-Row	1.40 (0.09)	15.4 (46.0)	0.54	0.7
	4-Row	1.40 (0.09)	3.7 (11.1)	1.11	1.5
03	2-Row	1.32 (0.08)	10.3 (30.7)	0.63	0.7
	3-Row	1.57 (0.10)	4.0 (11.8)	1.19	1.5
	4-Row	1.88 (0.12)	7.0 (20.8)	1.08	0.7
04	2-Row	1.68 (0.11)	3.7 (11.0)	1.33	1.5
	3-Row	2.25 (0.14)	8.6 (25.8)	1.17	1.5
	4-Row	2.54 (0.16)	13.6 (40.7)	1.05	0.7
06	2-Row	2.86 (0.18)	11.7 (34.9)	1.27	1.5
	3-Row	3.19 (0.20)	4.4 (13.1)	2.31	2.5
	4-Row	3.74 (0.24)	7.0 (20.9)	2.15	2.5
08	2-Row	3.14 (0.20)	3.8 (11.3)	2.45	2.5
	3-Row	4.01 (0.25)	7.5 (22.3)	2.23	2.5
	4-Row	4.44 (0.28)	10.8 (32.2)	2.05	2.5
10	2-Row	4.39 (0.28)	7.8 (23.2)	2.39	2.5
	3-Row	5.60 (0.35)	15.4 (46.1)	2.17	2.5
	4-Row	5.88 (0.37)	20.4 (61.0)	1.98	1.5
12	2-Row	5.28 (0.33)	11.8 (35.1)	2.34	2.5
	3-Row	6.14 (0.39)	11.2 (33.6)	2.79	2.5
	4-Row	7.23 (0.46)	15.4 (46.0)	2.80	2.5



# Performance Data

UniTrane® fan-coil performance data is submitted to ARI with units grouped based on performance. Unit performance is impacted by the unit model and the airflow inlet and outlet configuration. Below is a table which summarizes the performance groups.

**Table PD-1. Fan-Coil Performance Groupings**

Group Description	Unit Model	Inlet Style	Outlet Style	
Group 1	Horizontal Concealed (C)	Back Duct Collar	Front Duct Collar	
		Bottom Toe Space	Front Duct Collar	
	Horizontal Cabinet (D)	Open Return	Front Duct Collar	
		Back Duct Collar	Front Quad Grille	
		Back Duct Collar	Front Duct Collar	
Group 2	Horizontal Recessed (E)	Back Duct Collar	Front Duct Collar	
	Vertical Cabinet (B)	Front Toe Space	Top Quad Grille	
		Front Toe Space	Top Bar Grille	
		Front Bar Grille	Top Quad Grille	
	Vertical Concealed (A)	Front Bar Grille	Top Bar Grille	
		Front Toe Space	Top Duct Collar	
		Back Duct Collar	Front Bar Grille	
		Horizontal Cabinet (D)	Bottom Stamped Louver	Front Quad Grille
			Bottom Stamped Louver	Front Bar Grille
			Bottom Stamped Louver	Front Duct Collar
			Bottom Stamped Louver	Front Quad Grille
	Horizontal Recessed (E)	Back Stamped Louver	Front Bar Grille	
		Back Stamped Louver	Front Duct Collar	
Bottom Stamped Louver		Front Duct Collar		
Group 3	Vertical Recessed (H)	Front Stamped Louver	Front Stamped Louver	
		Front Stamped Louver	Top Duct Collar	
	Vertical Slope Top (J)	Front Toe Space	Top Quad Grille	
		Front Toe Space	Top Bar Grille	
		Front Bar Grille	Top Quad Grille	
Group 4	Low Vertical Cabinet (L)	Front Bar Grille	Top Quad Grille	
		Front Bar Grille	Top Bar Grille	
	Low Vertical Concealed (K)	Front Bar Grille	Top Bar Grille	
		Front Toe Space	Top Duct Collar	

Note:  
For performance conditions other than ARI, please use TOPSS™ (Trane Official Product Selection System) for fan-coils.



# Performance Data

# Two-Pipe Coils

ARI cooling performance is based on 80/67°F (27/19 C) entering air temperature, 45°F (7°C) entering chilled water temperature with a 10°F (5.5°C) ΔT.

Heating performance is based on 70°F (21°C) entering air temperature, 180°F (82°C) entering hot water temperature with a 30°F (17°C) ΔT.

All performance measured on high speed tap, 115 V, zero ESP, with a throwaway filter. See page 18 for performance groupings.

**Table PD-2. Free Discharge Motor, Two-Pipe, Group 1**

FC	Coil	Cfm (L/s)	Cooling				Heating						
			TMbh (TKW)	SMBh (SKW)	Gpm (L/s)	WPD (kPa)	TMbh (TKW)	Q/ITD	Gpm (L/s)	WPD (kPa)	115V Watt	230V Watt	277V Watt
2	2CH	240 (113)	5.4 (1.6)	4.2 (1.2)	1.11 (.07)	6.8 (20.4)	15.9 (4.7)	0.14	1.06 (.07)	4.8 (14.4)	60	95	65
	3CH	230 (108)	7.3 (2.1)	5.1 (1.5)	1.50 (.09)	17.4 (51.9)	19.6 (5.7)	0.18	1.31 (.08)	10.5 (31.4)	60	95	65
	4CH	210 (99)	7.3 (2.1)	5.1 (1.5)	1.49 (.09)	4.2 (12.6)	20.1 (6.0)	0.18	1.34 (.08)	2.8 (8.4)	60	95	65
3	2CH	318 (150)	6.7 (2.0)	5.1 (1.5)	1.39 (.09)	11.3 (33.9)	21.0 (6.2)	0.19	1.40 (.09)	8.8 (26.3)	70	80	83
	3CH	314 (148)	8.1 (2.4)	6.0 (1.8)	1.67 (.11)	4.4 (13.2)	25.6 (7.5)	0.23	1.70 (.11)	3.8 (11.3)	85	89	101
	4CH	284 (134)	9.7 (2.8)	6.7 (2.0)	1.99 (.13)	7.7 (23.0)	27.1 (7.9)	0.25	1.81 (.11)	5.3 (15.7)	85	89	101
4	2CH	388 (183)	8.6 (2.5)	6.8 (2.0)	1.78 (.11)	4.1 (12.2)	25.6 (7.5)	0.23	1.71 (.11)	3.2 (9.5)	95	96	104
	3CH	374 (177)	11.5 (3.4)	8.1 (2.4)	2.37 (.15)	9.5 (28.3)	31.8 (9.3)	0.29	2.12 (.13)	6.4 (19.0)	100	107	106
	4CH	350 (165)	13.0 (3.8)	8.7 (2.5)	2.66 (.17)	14.8 (44.4)	34.2 (10.0)	0.31	2.28 (.14)	9.1 (27.3)	100	107	106
6	2CH	611 (289)	14.7 (4.3)	11.1 (3.3)	3.02 (.19)	12.9 (38.6)	40.6 (11.9)	0.37	2.70 (.17)	8.9 (26.5)	110	154	165
	3CH	608 (287)	16.6 (4.9)	12.4 (3.6)	3.40 (.21)	4.9 (14.8)	49.7 (14.6)	0.45	3.31 (.21)	4.2 (12.6)	125	130	124
	4CH	565 (267)	19.4 (5.7)	13.3 (3.9)	3.96 (.25)	7.8 (23.2)	53.8 (15.8)	0.49	3.59 (.23)	5.7 (17.0)	125	130	124
8	2CH	790 (373)	16.2 (4.7)	13.1 (3.9)	3.32 (.21)	4.2 (12.5)	50.9 (14.9)	0.46	3.39 (.21)	4.0 (11.9)	135	150	159
	3CH	731 (345)	20.6 (6.1)	14.7 (4.3)	4.21 (.27)	8.2 (24.4)	61.6 (18.1)	0.56	4.11 (.26)	6.9 (20.7)	120	123	133
	4CH	688 (325)	22.8 (6.7)	15.5 (4.5)	4.65 (.29)	11.7 (35.0)	66.8 (19.6)	0.61	4.45 (.28)	9.4 (28.1)	120	123	133
10	2CH	980 (463)	22.5 (6.6)	17.5 (5.1)	4.64 (.29)	8.6 (25.8)	64.8 (19.0)	0.59	4.32 (.27)	6.8 (20.4)	205	250	269
	3CH	992 (468)	28.7 (8.4)	20.2 (5.9)	5.89 (.37)	17.0 (50.7)	83.3 (24.4)	0.76	5.55 (.35)	13.4 (40.2)	225	237	230
	4CH	930 (439)	29.9 (8.8)	20.1 (5.9)	6.14 (.39)	22.1 (66.0)	90.1 (26.4)	0.82	6.00 (.38)	18.3 (54.8)	225	237	230
12	2CH	1110 (524)	27.0 (7.9)	20.2 (5.9)	5.55 (.35)	12.9 (38.6)	75.0 (22.0)	0.68	4.99 (.32)	9.6 (28.6)	230	246	263
	3CH	1082 (511)	31.6 (9.3)	22.5 (6.6)	6.46 (.41)	12.4 (37.0)	91.5 (26.8)	0.83	6.10 (.38)	10.5 (31.4)	220	230	239
	4CH	1010 (477)	37.0 (10.8)	24.3 (7.1)	7.55 (.48)	16.7 (49.8)	99.3 (29.1)	0.90	6.62 (.42)	11.8 (35.2)	220	230	239

**Table PD-3. Free Discharge Motor, Two-Pipe, Group 2**

FC	Coil	Cfm (L/s)	Cooling				Heating						
			TMbh (TKW)	SMBh (SKW)	Gpm (L/s)	WPD (kPa)	TMbh (TKW)	Q/ITD	Gpm (L/s)	WPD (kPa)	115V Watt	230V Watt	277V Watt
2	2CH	211 (100)	5.0 (1.5)	3.8 (1.1)	1.04 (.07)	6.1 (18.2)	14.5 (4.3)	0.13	0.97 (.06)	4.1 (12.3)	60	95	65
	3CH	201 (95)	6.8 (2.0)	4.7 (1.4)	1.40 (.09)	15.4 (46.0)	17.7 (5.2)	0.16	1.18 (.07)	8.8 (26.2)	60	95	65
	4CH	188 (89)	6.8 (2.0)	4.7 (1.4)	1.40 (.09)	3.7 (11.1)	18.3 (5.4)	0.17	1.22 (.08)	2.4 (7.1)	60	95	65
3	2CH	280 (132)	6.4 (1.9)	4.8 (1.4)	1.32 (.08)	10.3 (30.7)	19.2 (5.6)	0.17	1.28 (.08)	7.5 (22.4)	70	80	83
	3CH	277 (131)	7.6 (2.2)	5.6 (1.7)	1.57 (.10)	4.0 (11.8)	23.3 (6.8)	0.21	1.55 (.10)	3.2 (9.5)	85	89	101
	4CH	256 (121)	9.1 (2.7)	6.3 (1.8)	1.88 (.12)	7.0 (20.8)	24.8 (7.3)	0.23	1.65 (.10)	4.5 (13.4)	85	89	101
4	2CH	349 (165)	8.1 (2.4)	6.4 (1.9)	1.68 (.11)	3.7 (11.0)	23.8 (7.0)	0.22	1.58 (.10)	2.8 (8.3)	95	96	104
	3CH	338 (159)	10.9 (3.2)	7.7 (2.3)	2.25 (.14)	8.6 (25.8)	29.4 (8.6)	0.27	1.96 (.12)	5.5 (16.5)	100	107	106
	4CH	320 (151)	12.4 (3.6)	8.2 (2.4)	2.54 (.16)	13.6 (40.7)	31.7 (9.3)	0.29	2.11 (.13)	7.9 (23.7)	100	107	106
6	2CH	544 (257)	13.9 (4.1)	10.4 (3.1)	2.86 (.18)	11.7 (34.9)	37.4 (11.0)	0.34	2.49 (.16)	7.6 (22.8)	110	154	165
	3CH	541 (255)	15.5 (4.6)	11.6 (3.4)	3.19 (.20)	4.4 (13.1)	45.4 (13.3)	0.41	3.03 (.19)	3.6 (10.6)	125	130	124
	4CH	510 (241)	18.3 (5.4)	12.5 (3.7)	3.74 (.24)	7.0 (20.9)	49.4 (14.5)	0.45	3.29 (.21)	4.8 (14.5)	125	130	124
8	2CH	706 (331)	15.3 (4.5)	12.3 (3.6)	3.14 (.20)	3.8 (11.3)	47.0 (13.8)	0.43	3.13 (.20)	3.4 (10.2)	135	150	159
	3CH	659 (311)	19.7 (5.8)	14.0 (4.1)	4.01 (.25)	7.5 (22.3)	56.8 (16.8)	0.52	3.79 (.24)	5.9 (17.8)	120	123	133
	4CH	627 (296)	21.8 (6.4)	14.7 (4.3)	4.44 (.28)	10.8 (32.2)	61.8 (18.1)	0.56	4.12 (.26)	8.1 (24.3)	120	123	133
10	2CH	879 (415)	21.2 (6.2)	16.3 (4.8)	4.39 (.28)	7.8 (23.2)	60.0 (17.6)	0.55	4.00 (.25)	5.9 (17.7)	205	250	269
	3CH	886 (418)	27.2 (8.0)	19.0 (5.6)	5.60 (.35)	15.4 (46.1)	76.4 (22.4)	0.69	5.09 (.32)	11.4 (34.1)	225	237	230
	4CH	840 (397)	28.6 (8.4)	19.1 (5.6)	5.88 (.37)	20.4 (61.0)	82.8 (24.3)	0.75	5.52 (.35)	15.7 (46.8)	225	237	230
12	2CH	996 (470)	25.6 (7.5)	19.0 (5.6)	5.28 (.33)	11.8 (35.1)	69.4 (20.3)	0.63	4.62 (.29)	8.3 (24.7)	230	246	263
	3CH	976 (461)	30.0 (8.8)	21.3 (6.2)	6.14 (.39)	11.2 (33.6)	84.3 (24.8)	0.77	5.62 (.35)	9.0 (26.8)	220	230	239
	4CH	921 (435)	35.4 (10.4)	23.2 (6.8)	7.23 (.46)	15.4 (46.0)	91.8 (26.9)	0.83	6.12 (.39)	10.2 (30.5)	220	230	239

Note:

1. Cfm = Cubic feet per minute
2. TMbh = Total capacity (MBh)
3. Gpm = Gallons per minute
4. WPD = Water pressure drop (feet of water)
5. Q/ITD = MBh (kW)/(Entering water temperature - Entering air temperature) when ΔT and gpm (L/s) remain constant. To determine heating capacities at a different entering water temperature or entering air temp, compute the new ITD and multiply it by the Q/ITD shown.
6. Medium and low speed capacities are approximately 80% and 60% respectively of the high speed capacity.



# Performance Data

# Two-Pipe Coils

ARI cooling performance is based on 80/67°F (27/19 C) entering air temperature, 45°F (7°C) entering chilled water temperature with a 10°F (5.5°C) ΔT.

Heating performance is based on 70°F (21°C) entering air temperature, 180°F (82°C) entering hot water temperature with a 30°F (17°C) ΔT.

All performance measured on high speed tap, 115 V, zero ESP, with a throwaway filter. See page 18 for performance groupings.

**Table PD-4. Free Discharge Motor, Two-Pipe, Group 3**

FC	Coil	Cooling				Heating							
		Cfm (L/s)	TMBh (TkW)	SMBh (SkW)	Gpm (L/s)	WPD (kPa)	TMBh (TkW)	Q/ITD	Gpm (L/s)	WPD (kPa)	115V Watt	230V Watt	277V Watt
2	2CH	198 (93)	4.8 (1.4)	3.7 (1.1)	1.00 (0.06)	5.7 (17.1)	13.8 (4.1)	.13	0.92 (0.06)	3.8 (11.3)	60	95	65
	3CH	188 (90)	6.5 (1.9)	4.5 (1.3)	1.34 (0.08)	14.4 (43.1)	16.7 (4.9)	.15	1.11 (0.07)	8.0 (23.8)	60	95	65
	4CH	177 (84)	6.5 (1.9)	4.5 (1.3)	1.34 (0.08)	3.5 (10.4)	17.3 (5.1)	.16	1.16 (0.07)	2.2 (6.4)	60	95	65
3	2CH	262 (124)	6.1 (1.8)	4.6 (1.3)	1.28 (0.08)	9.7 (29.1)	18.3 (5.4)	.17	1.22 (0.08)	6.9 (20.6)	70	80	83
	3CH	260 (123)	7.3 (2.1)	5.4 (1.6)	1.51 (0.10)	3.7 (11.1)	22.1 (6.5)	.20	1.47 (0.09)	2.9 (8.7)	85	89	101
	4CH	242 (114)	8.8 (2.6)	6.0 (1.8)	1.82 (0.11)	6.6 (19.6)	23.7 (6.9)	.22	1.58 (0.10)	4.1 (12.3)	85	89	101
4	2CH	330 (156)	7.8 (2.3)	6.2 (1.8)	1.63 (0.10)	3.5 (10.4)	22.8 (6.7)	.21	1.52 (0.10)	2.6 (7.7)	95	96	104
	3CH	320 (151)	10.6 (3.1)	7.4 (2.2)	2.19 (0.14)	8.2 (24.5)	28.1 (8.2)	.26	1.87 (0.12)	5.1 (15.2)	100	107	106
	4CH	304 (144)	12.0 (3.5)	8.0 (2.3)	2.47 (0.16)	12.9 (38.7)	30.3 (8.9)	.28	2.02 (0.13)	7.3 (21.9)	100	107	106
6	2CH	512 (242)	13.5 (4.0)	10.0 (2.9)	2.77 (0.17)	11.0 (32.9)	35.8 (10.5)	.33	2.38 (0.15)	7.0 (21.0)	110	154	165
	3CH	508 (240)	14.9 (4.4)	11.1 (3.3)	3.07 (0.19)	4.1 (12.3)	43.3 (12.7)	.39	2.88 (0.18)	3.3 (9.7)	125	130	124
	4CH	483 (228)	17.7 (5.2)	12.1 (3.5)	3.62 (0.23)	6.6 (19.7)	47.2 (13.8)	.43	3.14 (0.20)	4.4 (13.3)	125	130	124
8	2CH	665 (314)	14.7 (4.3)	11.9 (3.5)	3.04 (0.19)	3.6 (10.6)	45.0 (13.2)	.41	3.00 (0.19)	3.2 (9.4)	135	150	159
	3CH	623 (294)	19.1 (5.6)	13.5 (4.0)	3.90 (0.25)	7.1 (21.2)	54.3 (15.9)	.49	3.62 (0.23)	5.5 (16.3)	120	123	133
	4CH	596 (282)	21.2 (6.2)	14.3 (4.2)	4.32 (0.27)	10.3 (30.7)	59.2 (17.3)	.54	3.94 (0.25)	7.5 (22.4)	120	123	133
10	2CH	829 (391)	20.5 (6.0)	15.7 (4.6)	4.25 (0.27)	7.3 (21.8)	57.5 (16.9)	.52	3.83 (0.24)	5.5 (16.3)	205	250	269
	3CH	835 (394)	26.4 (7.7)	18.4 (5.4)	5.43 (0.34)	14.6 (43.7)	72.9 (21.3)	.66	4.86 (0.31)	10.5 (31.2)	225	237	230
	4CH	796 (376)	27.9 (8.2)	18.6 (5.4)	5.73 (0.36)	19.5 (58.3)	79.0 (23.1)	.72	5.26 (0.33)	14.4 (42.9)	225	237	230
12	2CH	940 (444)	24.9 (7.3)	18.4 (5.4)	5.13 (0.32)	11.1 (33.3)	66.5 (19.5)	.60	4.43 (0.28)	7.6 (22.8)	230	246	263
	3CH	923 (436)	29.1 (8.5)	20.6 (6.0)	5.96 (0.38)	10.6 (31.7)	80.6 (23.6)	.73	5.37 (0.34)	8.2 (24.6)	220	230	239
	4CH	876 (413)	34.5 (10.1)	22.5 (6.6)	7.04 (0.44)	14.7 (44.0)	87.9 (25.8)	.80	5.86 (0.37)	9.4 (28.2)	220	230	239

**Table PD-5. Free Discharge Motor, Two-Pipe, Group 4**

FC	Coil	Cooling				Heating					
		Cfm (L/s)	TMBh (TkW)	SMBh (SkW)	Gpm (L/s)	WPD (kPa)	TMBh (TkW)	Q/ITD	Gpm (L/s)	WPD (kPa)	115V Watt
3	2CH	300 (142)	6.8 (2.0)	5.4 (1.6)	1.36 (0.09)	2.5 (7.5)	21.2 (6.2)	.19	1.41 (0.09)	2.3 (6.7)	86
	3CH	270 (128)	7.8 (2.3)	5.5 (1.6)	1.56 (0.10)	4.5 (13.4)	24.4 (7.1)	.22	1.62 (0.10)	3.9 (11.7)	86
4	2CH	380 (179)	10.7 (3.1)	7.7 (2.3)	2.14 (0.13)	6.9 (20.7)	28.3 (8.3)	.26	1.89 (0.12)	4.6 (13.7)	98
	3CH	350 (165)	10.0 (3.0)	7.4 (2.2)	2.00 (0.13)	1.9 (5.5)	31.5 (9.2)	.29	2.10 (0.13)	1.8 (5.4)	98
6	2CH	620 (293)	13.6 (4.0)	11.1 (3.3)	2.71 (0.17)	2.9 (8.6)	42.8 (12.5)	.39	2.85 (0.18)	2.9 (8.6)	105
	3CH	570 (269)	16.4 (4.8)	11.7 (3.4)	3.28 (0.21)	5.2 (15.4)	50.5 (14.8)	.46	3.36 (0.21)	4.8 (14.2)	105

Note:

1. Cfm = Cubic feet per minute
2. TMBh = Total capacity (MBh)
3. Gpm = Gallons per minute
4. WPD = Water pressure drop (feet of water)
5. Q/ITD = MBh (kW)/(Entering water temperature - Entering air temperature) when ΔT and gpm (L/s) remain constant. To determine heating capacities at a different entering water temperature or entering air temp, compute the new ITD and multiply it by the Q/ITD shown.
6. Medium and low speed capacities are approximately 80% and 60% respectively of the high speed capacity.



# Performance Data

# Two-Pipe Coils

ARI cooling performance is based on 80/67°F (27/19 C) entering air temperature, 45°F (7°C) entering chilled water temperature with a 10°F (5.5°C) ΔT.

Heating performance is based on 70°F (21°C) entering air temperature, 180°F (82°C) entering hot water temperature with a 30°F (17°C) ΔT.

All performance measured on high speed tap, 115 V, zero ESP, with a throwaway filter. See page 18 for performance groupings.

**Table PD-6. High Static Motor, Two-Pipe, Group 1**

FC	Coil	Cfm (L/s)	Cooling				Heating						
			TMBh (TkW)	SMBh (SkW)	Gpm (L/s)	WPD (kPa)	TMBh (TkW)	Q/ITD	Gpm (L/s)	WPD (kPa)	115V Watt	230V Watt	277V Watt
2	2CH	287 (135)	5.9 (1.7)	4.7(1.4)	1.29 (0.08)	8.8 (26.3)	17.9 (5.3)	.16	1.19 (0.08)	6.0 (17.8)	145	145	145
	3CH	282 (133)	8.5 (2.5)	6.1 (1.8)	1.80 (0.11)	23.9 (71.3)	22.9 (6.7)	.21	1.52 (0.10)	13.8 (41.2)	145	145	145
	4CH	260 (123)	8.7 (2.6)	6.2 (1.8)	1.84 (0.12)	6.1 (18.3)	23.9 (7.0)	.22	1.59 (0.10)	3.8 (11.5)	145	145	145
3	2CH	365 (172)	7.4 (2.2)	5.7 (1.7)	1.58 (0.10)	14.1 (42.2)	23.0 (6.7)	.21	1.53 (0.10)	10.3 (30.8)	140	140	140
	3CH	343 (162)	8.8 (2.6)	6.7 (2.0)	1.86 (0.12)	5.4 (16.1)	27.3 (8.0)	.25	1.82 (0.11)	4.3 (12.8)	145	140	135
	4CH	318 (150)	10.8 (3.2)	7.6 (2.2)	2.26 (0.14)	9.7 (28.9)	29.7 (8.7)	.27	1.98 (0.12)	6.2 (18.6)	145	140	135
4	2CH	396 (187)	8.9 (2.6)	7.1 (2.1)	1.90 (0.12)	4.6 (13.7)	26.0 (7.6)	.24	1.73 (0.11)	3.3 (9.8)	170	180	170
	3CH	484 (228)	14.0 (4.1)	10.2 (3.0)	2.94 (0.19)	13.9 (41.5)	38.6 (11.3)	.35	2.57 (0.16)	9.1 (27.0)	210	210	210
	4CH	453 (214)	16.0 (4.7)	11.0 (3.2)	3.35 (0.21)	22.3 (66.7)	42.2 (12.4)	.38	2.81 (0.18)	13.4 (39.9)	210	210	210
6	2CH	668 (315)	15.8 (4.6)	12.1 (3.5)	3.32 (0.21)	15.3 (45.6)	43.1 (12.6)	.39	2.87 (0.18)	9.9 (29.5)	245	240	240
	3CH	780 (368)	20.1 (5.9)	15.5 (4.5)	4.24 (0.27)	7.5 (22.3)	59.5 (17.4)	.54	3.96 (0.25)	5.9 (17.7)	320	320	320
	4CH	725 (342)	23.9 (7.0)	16.8 (4.9)	4.99 (0.31)	11.9 (35.6)	65.6 (19.2)	.60	4.37 (0.28)	8.2 (24.6)	320	320	320
8	2CH	907 (428)	18.4 (5.4)	15.2 (4.5)	3.90 (0.25)	5.7 (16.9)	55.7 (16.3)	.51	3.71 (0.23)	4.7 (14.2)	320	320	320
	3CH	886 (418)	24.6 (7.2)	17.9 (5.3)	5.13 (0.32)	11.8 (35.2)	71.2 (20.9)	.65	4.74 (0.30)	9.1 (27.1)	320	320	320
	4CH	835 (394)	27.3 (8.0)	18.9 (5.5)	5.68 (0.36)	16.9 (50.6)	78.3 (22.9)	.71	5.22 (0.33)	12.7 (37.8)	320	320	320
10	2CH	1117 (527)	24.7 (7.3)	19.5 (5.7)	5.23 (0.33)	10.8 (32.2)	70.8 (20.7)	.65	4.71 (0.30)	8.1 (24.1)	415	420	410
	3CH	1230 (580)	33.9 (9.9)	24.5 (7.2)	7.14 (0.45)	24.2 (72.3)	97.6 (28.6)	.89	6.50 (0.41)	18.1 (54.0)	530	530	530
	4CH	1152 (544)	36.2 (10.6)	24.8 (7.3)	7.63 (0.48)	32.8 (98.1)	107.1 (31.4)	.97	7.13 (0.45)	25.3 (75.6)	530	530	530
12	2CH	1270 (600)	30.1 (8.8)	23.0 (6.8)	6.35 (0.40)	16.6 (49.5)	82.2 (24.1)	.75	5.48 (0.35)	11.4 (34.0)	490	500	490
	3CH	1350 (637)	38.1 (11.2)	27.9 (8.2)	7.98 (0.50)	18.5 (55.3)	108.0 (31.6)	.98	7.19 (0.45)	14.5 (43.2)	530	530	530
	4CH	1274 (601)	45.6 (13.4)	30.6 (9.0)	9.47 (0.60)	25.2 (75.4)	120.0 (35.2)	1.09	8.00 (0.50)	16.7 (50.0)	530	530	530

**Table PD-7. High Static Motor, Two-Pipe, Group 2**

FC	Coil	Cfm (L/s)	Cooling				Heating						
			TMBh (TkW)	SMBh (SkW)	Gpm (L/s)	WPD (kPa)	TMBh (TkW)	Q/ITD	Gpm (L/s)	WPD (kPa)	115V Watt	230V Watt	277V Watt
2	2CH	256 (121)	5.6 (1.6)	4.4 (1.3)	1.22 (0.08)	8.0 (23.9)	16.6 (4.9)	.15	1.11 (0.07)	5.2 (15.5)	145	145	145
	3CH	250 (118)	8.0 (2.3)	5.7 (1.7)	1.69 (0.11)	21.5 (64.1)	20.9 (6.1)	.19	1.39 (0.09)	11.8 (35.3)	145	145	145
	4CH	234 (111)	8.2 (2.4)	5.8 (1.7)	1.74 (0.11)	5.5 (16.4)	22.0 (6.5)	.20	1.47 (0.09)	3.3 (9.9)	145	145	145
3	2CH	330 (156)	7.1 (2.1)	5.4 (1.6)	1.51 (0.10)	13.1 (39.0)	21.5 (6.3)	.20	1.43 (0.09)	9.2 (27.4)	140	140	140
	3CH	309 (146)	8.3 (2.4)	6.3 (1.9)	1.76 (0.11)	4.9 (14.6)	25.3 (7.4)	.23	1.68 (0.11)	3.7 (11.1)	145	140	135
	4CH	290 (137)	10.3 (3.0)	7.1 (2.1)	2.15 (0.14)	8.8 (26.4)	27.6 (8.1)	.25	1.84 (0.12)	5.4 (16.3)	145	140	135
4	2CH	367 (173)	8.5 (2.5)	6.8 (2.0)	1.82 (0.11)	4.3 (12.7)	24.6 (7.2)	.22	1.64 (0.10)	3.0 (8.9)	170	180	170
	3CH	440 (208)	13.3 (3.9)	9.6 (2.8)	2.80 (0.18)	12.8 (38.1)	36.0 (10.5)	.33	2.40 (0.15)	8.0 (23.8)	210	210	210
	4CH	416 (196)	15.3 (4.5)	10.4 (3.1)	3.20 (0.20)	20.6 (61.6)	39.5 (11.6)	.36	2.63 (0.17)	11.8 (35.3)	210	210	210
6	2CH	610 (288)	15.0 (4.4)	11.4 (3.4)	3.17 (0.20)	14.1 (42.1)	40.5 (11.9)	.37	2.70 (0.17)	8.8 (26.4)	245	240	240
	3CH	704 (332)	19.0 (5.6)	14.5 (4.2)	4.02 (0.25)	6.8 (20.2)	55.3 (16.2)	.50	3.68 (0.23)	5.2 (15.4)	320	320	320
	4CH	662 (312)	22.7 (6.6)	15.9 (4.7)	4.75 (0.30)	10.9 (32.5)	61.1 (17.9)	.56	4.07 (0.26)	7.2 (21.5)	320	320	320
8	2CH	834 (394)	17.6 (5.2)	14.5 (4.2)	3.74 (0.24)	5.3 (15.7)	52.7 (15.5)	.48	3.51 (0.22)	4.3 (12.7)	320	320	320
	3CH	815 (385)	23.6 (6.9)	17.1 (5.0)	4.94 (0.31)	10.9 (32.7)	66.9 (19.6)	.61	4.46 (0.28)	8.1 (24.1)	320	320	320
	4CH	775 (366)	26.2 (7.7)	18.1 (5.3)	5.47 (0.34)	15.8 (47.1)	73.7 (21.6)	.67	4.91 (0.31)	11.3 (33.8)	320	320	320
10	2CH	1029 (486)	23.7 (6.9)	18.5 (5.4)	5.02 (0.32)	10.0 (29.8)	67.0 (19.6)	.61	4.46 (0.28)	7.3 (21.8)	415	420	410
	3CH	1117 (527)	32.3 (9.5)	23.2 (6.8)	6.83 (0.43)	22.3 (66.6)	91.0 (26.7)	.83	6.06 (0.38)	15.9 (47.4)	530	530	530
	4CH	1057 (499)	34.9 (10.2)	23.7 (7.0)	7.34 (0.46)	30.6 (91.4)	100.0 (29.3)	.91	6.66 (0.42)	22.3 (66.6)	530	530	530
12	2CH	1175 (554)	28.9 (8.5)	22.0 (6.4)	6.12 (0.39)	15.5 (46.2)	78.0 (22.8)	.71	5.19 (0.33)	10.3 (30.8)	490	500	490
	3CH	1242 (586)	36.5 (10.7)	26.5 (7.8)	7.66 (0.48)	17.1 (51.2)	101.5 (29.8)	.92	6.77 (0.43)	12.8 (38.4)	530	530	530
	4CH	1181 (557)	43.8 (12.8)	29.3 (8.6)	9.12 (0.58)	23.5 (70.3)	113.0 (33.1)	1.03	7.53 (0.47)	14.9 (44.6)	530	530	530

Note:

1. Cfm = Cubic feet per minute
2. TMBh = Total capacity (MBh)
3. Gpm = Gallons per minute
4. WPD = Water pressure drop (feet of water)
5. Q/ITD = MBh (kW)/(Entering water temperature - Entering air temperature) when ΔT and gpm (L/s) remain constant. To determine heating capacities at a different entering water temperature or entering air temp, compute the new ITD and multiply it by the Q/ITD shown.
6. Medium and low speed capacities are approximately 80% and 60% respectively of the high speed capacity.
7. High static motors need the appropriate length of duct to prevent poor acoustical applications.



# Performance Data

# Four-Pipe Coils

ARI cooling performance is based on 80/67°F (27/19 C) entering air temperature, 45°F (7°C) entering chilled water temperature with a 10°F (5.5°C) ΔT.

Heating performance is based on 70°F (21°C) entering air temperature, 180°F (82°C) entering hot water temperature with a 30°F (17°C) ΔT.

All performance measured on high speed tap, 115 V, zero ESP, with a throwaway filter. See page 18 for performance groupings.

**Table PD-8. Free Discharge Motor, Four-Pipe, Group 1**

FC	Coil	Cfm (L/s)	Cooling				Heating						
			TMBh (TKW)	SMBh (SKW)	Gpm (L/s)	WPD (kPa)	TMBh (TKW)	Q/ITD	Gpm (L/s)	WPD (kPa)	115V Watt	230V Watt	277V Watt
2	2C1H	230 (108)	5.2 (1.5)	4.0 (1.2)	1.08 (0.07)	6.5 (19.4)	8.7 (2.5)	.08	0.58 (0.04)	0.8 (2.4)	60	95	65
	2C2H	210 (99)	4.9 (1.5)	3.8 (1.1)	1.03 (0.06)	6.0 (17.8)	14.5 (4.2)	.13	0.96 (0.06)	4.1 (12.2)	60	95	65
	3C1H	210 (99)	6.9 (2.0)	4.8 (1.4)	1.42 (0.09)	15.9 (47.6)	8.2 (2.4)	.07	0.54 (0.03)	0.7 (2.2)	60	95	65
3	2C1H	314 (148)	6.7 (2.0)	5.0 (1.5)	1.39 (0.09)	11.3 (33.8)	11.7 (3.4)	.11	0.78 (0.05)	1.5 (4.6)	85	89	101
	2C2H	284 (134)	6.3 (1.9)	4.7 (1.4)	1.33 (0.08)	10.4 (31.1)	19.4 (5.7)	.18	1.29 (0.08)	7.6 (22.8)	85	89	101
	3C1H	284 (134)	7.6 (2.2)	5.7 (1.7)	1.58 (0.10)	4.0 (12.0)	11.0 (3.2)	.10	0.74 (0.05)	1.4 (4.1)	85	89	101
4	2C1H	374 (177)	8.4 (2.5)	6.6 (2.0)	1.74 (0.11)	3.9 (11.7)	15.0 (4.4)	.14	1.00 (0.06)	2.8 (8.4)	100	107	106
	2C2H	350 (165)	8.0 (2.4)	6.4 (1.9)	1.67 (0.11)	3.7 (11.0)	23.8 (7.0)	.22	1.59 (0.10)	2.8 (8.3)	100	107	106
	3C1H	350 (165)	11.1 (3.3)	7.8 (2.3)	2.28 (0.14)	8.9 (26.5)	14.4 (4.2)	.13	0.96 (0.06)	2.6 (7.8)	100	107	106
6	2C1H	608 (287)	14.7 (4.3)	11.1 (3.2)	3.01 (0.19)	12.8 (38.4)	24.2 (7.1)	.22	1.61 (0.10)	8.4 (25.2)	125	130	124
	2C2H	565 (267)	14.1 (4.1)	10.6 (3.1)	2.91 (0.18)	12.0 (36.0)	38.4 (11.3)	.35	2.56 (0.16)	8.0 (23.9)	125	130	124
	3C1H	565 (267)	15.9 (4.7)	11.8 (3.5)	3.26 (0.21)	4.6 (13.7)	23.1 (6.8)	.21	1.54 (0.10)	7.8 (23.3)	125	130	124
8	2C1H	731 (345)	15.4 (4.5)	12.5 (3.7)	3.16 (0.20)	3.8 (11.4)	30.2 (8.9)	.27	2.01 (0.13)	15.1 (45.1)	120	123	133
	2C2H	688 (325)	14.8 (4.4)	12.0 (3.5)	3.05 (0.19)	3.6 (10.7)	46.2 (13.5)	.42	3.08 (0.19)	3.3 (9.9)	120	123	133
	3C1H	688 (325)	20.0 (5.9)	14.2 (4.2)	4.08 (0.26)	7.7 (23.0)	29.1 (8.5)	.26	1.94 (0.12)	14.1 (42.1)	120	123	133
10	2C1H	992 (468)	22.6 (6.6)	17.5 (5.1)	4.67 (0.29)	8.7 (26.1)	40.5 (11.9)	.37	2.70 (0.17)	30.7 (91.7)	225	237	230
	2C2H	930 (439)	21.8 (6.4)	16.8 (4.9)	4.51 (0.28)	8.2 (24.4)	62.5 (18.3)	.57	4.16 (0.26)	6.4 (19.1)	225	237	230
	3C1H	930 (439)	27.7 (8.1)	19.4 (5.7)	5.70 (0.36)	16.0 (47.7)	38.9 (11.4)	.35	2.59 (0.16)	28.5 (85.3)	225	237	230
12	2C1H	1082 (511)	26.6 (7.8)	19.9 (5.8)	5.47 (0.35)	12.6 (37.6)	45.7 (13.4)	.42	3.04 (0.19)	43.3 (129.5)	220	230	239
	2C2H	1010 (477)	25.6 (7.5)	19.1 (5.6)	5.28 (0.33)	11.8 (35.1)	70.1 (20.5)	.64	4.67 (0.29)	8.4 (25.2)	220	230	239
	3C1H	1010 (477)	30.4 (8.9)	21.6 (6.3)	6.22 (0.39)	11.5 (34.4)	43.7 (12.8)	.40	2.91 (0.18)	40.0 (119.5)	220	230	239

**Table PD-9. Free Discharge Motor, Four-Pipe, Group 2**

FC	Coil	Cfm (L/s)	Cooling				Heating						
			TMBh (TKW)	SMBh (SKW)	Gpm (L/s)	WPD (kPa)	TMBh (TKW)	Q/ITD	Gpm (L/s)	WPD (kPa)	115V Watt	230V Watt	277V Watt
2	2C1H	201 (95)	4.8 (1.4)	3.7 (1.1)	1.01 (0.06)	5.8 (17.2)	8.0 (2.3)	.07	0.53 (0.03)	0.7 (2.1)	60	95	65
	2C2H	188 (89)	4.6 (1.4)	3.5 (1.0)	0.97 (0.06)	5.4 (16.0)	13.3 (3.9)	.12	0.89 (0.06)	3.5 (10.5)	60	95	65
	3C1H	188 (89)	6.5 (1.9)	4.5 (1.3)	1.34 (0.08)	14.3 (42.7)	7.6 (2.2)	.07	0.50 (0.03)	0.6 (1.9)	60	95	65
3	2C1H	277 (131)	6.3 (1.9)	4.7 (1.4)	1.32 (0.08)	10.3 (30.8)	10.9 (3.2)	.10	0.72 (0.05)	1.4 (4.0)	85	89	101
	2C2H	256 (121)	6.0 (1.8)	4.5 (1.3)	1.26 (0.08)	9.6 (28.6)	18.0 (5.3)	.16	1.20 (0.08)	6.7 (20.0)	85	89	101
	3C1H	256 (121)	7.2 (2.1)	5.3 (1.6)	1.49 (0.09)	3.6 (10.8)	10.3 (3.0)	.09	0.69 (0.04)	1.2 (3.7)	85	89	101
4	2C1H	338 (159)	7.9 (2.3)	6.2 (1.8)	1.65 (0.10)	3.6 (10.6)	14.0 (4.1)	.13	0.94 (0.06)	2.5 (7.5)	100	107	106
	2C2H	320 (151)	7.6 (2.2)	6.0 (1.8)	1.59 (0.10)	3.4 (10.0)	22.3 (6.5)	.20	1.48 (0.09)	2.5 (7.4)	100	107	106
	3C1H	320 (151)	10.6 (3.1)	7.4 (2.2)	2.18 (0.14)	8.1 (24.3)	13.5 (4.0)	.12	0.90 (0.06)	2.3 (7.0)	100	107	106
6	2C1H	541 (255)	13.8 (4.1)	10.3 (3.0)	2.85 (0.18)	11.6 (34.7)	22.4 (6.6)	.20	1.50 (0.09)	7.4 (22.1)	125	130	124
	2C2H	510 (241)	13.4 (3.9)	9.9 (2.9)	2.76 (0.17)	11.0 (32.8)	35.7 (10.5)	.32	2.38 (0.15)	7.0 (20.9)	125	130	124
	3C1H	510 (241)	14.9 (4.4)	11.1 (3.3)	3.07 (0.19)	4.1 (12.2)	21.6 (6.3)	.20	1.44 (0.09)	6.9 (20.7)	125	130	124
8	2C1H	659 (311)	14.6 (4.3)	11.7 (3.4)	2.99 (0.19)	3.4 (10.3)	28.3 (8.3)	.26	1.88 (0.12)	13.4 (40.1)	120	123	133
	2C2H	627 (296)	14.1 (4.1)	11.3 (3.3)	2.90 (0.18)	3.3 (9.7)	43.2 (12.7)	.39	2.88 (0.18)	2.9 (8.7)	120	123	133
	3C1H	627 (296)	19.1 (5.6)	13.5 (4.0)	3.90 (0.25)	7.1 (21.2)	27.3 (8.0)	.25	1.82 (0.11)	12.6 (37.7)	120	123	133
10	2C1H	886 (418)	21.3 (6.2)	16.4 (4.8)	4.41 (0.28)	7.8 (23.4)	37.7 (11.0)	.34	2.51 (0.16)	27.0 (80.8)	225	237	230
	2C2H	840 (397)	20.6 (6.0)	15.8 (4.6)	4.27 (0.27)	7.4 (22.1)	58.1 (17.0)	.53	3.87 (0.24)	5.6 (16.6)	225	237	230
	3C1H	840 (397)	26.4 (7.7)	18.4 (5.4)	5.43 (0.34)	14.6 (43.6)	36.4 (10.7)	.33	2.42 (0.15)	25.4 (75.9)	225	237	230
12	2C1H	976 (461)	25.3 (7.4)	18.8 (5.5)	5.21 (0.33)	11.5 (34.3)	42.7 (12.5)	.39	2.84 (0.18)	38.4 (114.7)	220	230	239
	2C2H	921 (435)	24.5 (7.2)	18.0 (5.3)	5.04 (0.32)	10.8 (32.2)	65.4 (19.2)	.59	4.36 (0.28)	7.4 (22.1)	220	230	239
	3C1H	921 (435)	28.9 (8.5)	20.4 (6.0)	5.93 (0.37)	10.5 (31.4)	41.0 (12.0)	.37	2.73 (0.17)	35.8 (106.9)	220	230	239

- Note:
1. Cfm = Cubic feet per minute
  2. TMBh = Total capacity (MBh)
  3. Gpm = Gallons per minute
  4. WPD = Water pressure drop (feet of water)
  5. Q/ITD = MBh (kW)/(Entering water temperature - Entering air temperature) when ΔT and gpm (L/s) remain constant. To determine heating capacities at a different entering water temperature or entering air temp, compute the new ITD and multiply it by the Q/ITD shown.
  6. Medium and low speed capacities are approximately 80% and 60% respectively of the high speed capacity.



# Performance Data

# Four-Pipe Coils

ARI cooling performance is based on 80/67°F (27/19 C) entering air temperature, 45°F (7°C) entering chilled water temperature with a 10°F (5.5°C) ΔT.

Heating performance is based on 70°F (21°C) entering air temperature, 180°F (82°C) entering hot water temperature with a 30°F (17°C) ΔT.

All performance measured on high speed tap, 115 V, zero ESP, with a throwaway filter. See page 18 for performance groupings.

**Table PD-10. Free Discharge Motor, Four-Pipe, Group 3**

FC	Coil	Cfm (L/s)	Cooling				Heating						
			TMBh (TkW)	SMBh (SkW)	Gpm (L/s)	WPD (kPa)	TMBh (TkW)	Q/ITD	Gpm (L/s)	WPD (kPa)	115V Watt	230V Watt	277V Watt
2	2C1H	188 (89)	4.7 (1.4)	3.5 (1.0)	0.97 (0.06)	5.4 (16.2)	7.6 (2.2)	.07	0.51 (0.03)	0.6 (1.9)	60	95	65
	2C2H	177 (84)	4.5 (1.3)	3.4 (1.0)	0.93 (0.06)	5.1 (15.1)	12.7 (3.7)	.12	0.85 (0.05)	3.2 (9.7)	60	95	65
	3C1H	177 (84)	6.3 (1.8)	4.3 (1.3)	1.29 (0.08)	13.4 (40.1)	7.3 (2.1)	.07	0.48 (0.03)	0.6 (1.8)	60	95	65
3	2C1H	260 (123)	6.1 (1.8)	4.5 (1.3)	1.28 (0.08)	9.8 (29.2)	10.4 (3.1)	.09	0.69 (0.04)	1.3 (3.8)	85	89	101
	2C2H	242 (114)	5.9 (1.7)	4.3 (1.3)	1.23 (0.08)	9.1 (27.2)	17.2 (5.1)	.16	1.15 (0.07)	6.2 (18.6)	85	89	101
	3C1H	242 (114)	6.9 (2.0)	5.1 (1.5)	1.45 (0.09)	3.4 (10.2)	9.9 (2.9)	.09	0.66 (0.04)	1.2 (3.4)	85	89	101
4	2C1H	320 (151)	7.7 (2.2)	6.0 (1.8)	1.60 (0.10)	3.4 (10.1)	13.5 (4.0)	.12	0.90 (0.06)	2.3 (7.0)	100	107	106
	2C2H	304 (144)	7.4 (2.2)	5.8 (1.7)	1.55 (0.10)	3.2 (9.5)	21.4 (6.3)	.19	1.43 (0.09)	2.3 (6.9)	100	107	106
	3C1H	304 (144)	10.3 (3.0)	7.2 (2.1)	2.12 (0.13)	7.7 (23.1)	13.1 (3.8)	.12	0.87 (0.05)	2.2 (6.6)	100	107	106
6	2C1H	508 (240)	13.4 (3.9)	9.9 (2.9)	2.76 (0.17)	11.0 (32.8)	21.6 (6.3)	.20	1.44 (0.09)	6.9 (20.6)	125	130	124
	2C2H	483 (228)	13.0 (3.8)	9.6 (2.8)	2.68 (0.17)	10.4 (31.1)	34.3 (10.0)	.31	2.28 (0.14)	6.5 (19.4)	125	130	124
	3C1H	483 (228)	14.4 (4.2)	10.7 (3.1)	2.97 (0.19)	3.8 (11.5)	20.8 (6.1)	.19	1.39 (0.09)	6.5 (19.4)	125	130	124
8	2C1H	623 (294)	14.1 (4.1)	11.3 (3.3)	2.90 (0.18)	3.2 (9.7)	27.2 (8.0)	.25	1.81 (0.11)	12.5 (37.5)	120	123	133
	2C2H	596 (282)	13.7 (4.0)	11.0 (3.2)	2.81 (0.18)	3.1 (9.2)	41.6 (12.2)	.38	2.77 (0.17)	2.7 (8.1)	120	123	133
	3C1H	596 (282)	18.6 (5.5)	13.1 (3.8)	3.80 (0.24)	6.8 (20.2)	26.4 (7.7)	.24	1.76 (0.11)	11.9 (35.5)	120	123	133
10	2C1H	835 (394)	20.6 (6.0)	15.8 (4.6)	4.27 (0.27)	7.4 (22.1)	36.2 (10.6)	.33	2.41 (0.15)	25.2 (75.3)	225	237	230
	2C2H	796 (376)	20.0 (5.9)	15.2 (4.5)	4.15 (0.26)	7.0 (20.9)	55.8 (16.3)	.51	3.72 (0.23)	5.2 (15.4)	225	237	230
	3C1H	796 (376)	25.6 (7.5)	17.8 (5.2)	5.28 (0.33)	13.9 (41.4)	35.1 (10.3)	.32	2.34 (0.15)	23.8 (71.0)	225	237	230
12	2C1H	923 (436)	24.6 (7.2)	18.1 (5.3)	5.06 (0.32)	10.9 (32.5)	41.1 (12.0)	.37	2.74 (0.17)	35.9 (107.2)	220	230	239
	2C2H	876 (413)	23.8 (7.0)	17.5 (5.1)	4.91 (0.31)	10.3 (30.7)	63.0 (18.5)	.57	4.20 (0.26)	6.9 (20.6)	220	230	239
	3C1H	876 (413)	28.1 (8.2)	19.8 (5.8)	5.76 (0.36)	10.0 (29.7)	39.6 (11.6)	.36	2.64 (0.17)	33.6 (100.4)	220	230	239

**Table PD-11. Free Discharge Motor, Four-Pipe, Group 4**

FC	Coil	Cfm (L/s)	Cooling				Heating				
			TMBh (TkW)	SMBh (SkW)	Gpm (L/s)	WPD (kPa)	TMBh (TkW)	Q/ITD	Gpm (L/s)	WPD (kPa)	115V Watt
3	2C1H	270 (128)	6.3 (1.9)	5.0 (1.5)	1.26 (0.08)	2.2 (6.6)	12.0 (3.5)	.11	0.80 (0.05)	1.9 (5.7)	86
	2C2H	250 (118)	5.9 (1.7)	4.7 (1.4)	1.18 (0.07)	2.0 (5.8)	18.3 (5.4)	.17	1.22 (0.08)	1.7 (5.1)	86
	3C1H	250 (118)	7.3 (2.1)	5.1 (1.5)	1.46 (0.09)	4.0 (11.9)	11.3 (3.3)	.10	0.75 (0.05)	1.7 (5.1)	86
4	2C1H	350 (165)	10.0 (2.9)	7.1 (2.1)	1.99 (0.13)	6.1 (18.2)	16.3 (4.8)	.15	1.09 (0.07)	4.2 (12.6)	98
	2C2H	320 (151)	9.2 (2.7)	6.5 (2.0)	1.83 (0.12)	5.2 (15.7)	24.4 (7.2)	.22	1.63 (0.10)	3.5 (10.5)	98
	3C1H	320 (151)	8.9 (2.6)	6.6 (1.9)	1.79 (0.11)	1.5 (4.5)	15.1 (4.4)	.14	1.01 (0.06)	3.7 (11.1)	98
6	2C1H	570 (270)	12.6 (3.7)	10.3 (3.0)	2.52 (0.16)	2.5 (7.5)	25.6 (7.5)	.23	1.70 (0.11)	11.2 (33.5)	105
	2C2H	530 (250)	11.7 (3.4)	9.6 (2.8)	2.35 (0.22)	2.2 (6.6)	37.9 (11.1)	.34	2.53 (0.160)	2.3 (6.8)	105
	3C1H	530 (250)	15.3 (4.5)	10.8 (3.2)	3.07 (0.19)	4.5 (13.6)	24.2 (7.1)	.22	1.61 (0.10)	10.2 (30.5)	105

Note:

1. Medium and low speed capacities are approximately 80% and 60% respectively of the high speed capacity.
2. Q/ITD = MBh (kW)/(Entering water temperature - Entering air temperature) when ΔT and gpm (L/s) remain constant. To determine heating capacities at a different entering water temperature or entering air temperature, compute the new ITD and multiply it by the Q/ITD shown.



# Performance Data

# Four-Pipe Coils

ARI cooling performance is based on 80/67°F (27/19 C) entering air temperature, 45°F (7°C) entering chilled water temperature with a 10°F (5.5°C) ΔT.

Heating performance is based on 70°F (21°C) entering air temperature, 180°F (82°C) entering hot water temperature with a 30°F (17°C) ΔT.

All performance measured on high speed tap, 115 V, zero ESP, with a throwaway filter. See page 18 for performance groupings.

**Table PD-12. High Static Motor, Four-Pipe, Group 1**

FC	Coil	Cooling					Heating						
		Cfm (L/s)	TMBh (TkW)	SMBh (SkW)	Gpm (L/s)	WPD (kPa)	TMBh (TkW)	Q/ITD	Gpm (L/s)	WPD (kPa)	115V Watt	230V Watt	277V Watt
2	2C1H	282 (133)	5.9 (1.7)	4.7 (1.4)	1.27 (0.08)	8.6 (25.8)	9.8 (2.9)	.09	0.65 (0.04)	1.0 (3.0)	145	145	145
	2C2H	260 (123)	5.6 (1.7)	4.4 (1.3)	1.22 (0.08)	8.1 (24.1)	16.8 (4.9)	.15	1.12 (0.07)	5.3 (15.8)	145	145	145
	3C1H	260 (123)	8.1 (2.4)	5.8 (1.7)	1.72 (0.11)	22.1 (66.1)	9.3 (2.8)	.08	0.62 (0.04)	0.9 (2.7)	145	145	145
3	2C1H	343 (162)	7.2 (2.1)	5.5 (1.6)	1.53 (0.10)	13.3 (39.9)	12.4 (3.6)	.11	0.82 (0.05)	1.7 (5.1)	145	140	135
	2C2H	318 (150)	6.9 (2.0)	5.2 (1.5)	1.48 (0.09)	12.5 (37.5)	21.0 (6.2)	.19	1.40 (0.09)	8.8 (26.3)	145	140	135
	3C1H	318 (150)	8.4 (2.5)	6.4 (1.9)	1.79 (0.11)	5.0 (14.9)	11.8 (3.5)	.11	0.79 (0.05)	1.6 (4.7)	145	140	135
4	2C1H	484 (228)	9.9 (2.9)	8.1 (2.4)	2.13 (0.13)	5.6 (16.9)	17.5 (5.1)	.16	1.17 (0.07)	3.7 (11.1)	210	210	210
	2C2H	453 (214)	9.6 (2.8)	7.8 (2.3)	2.06 (0.13)	5.3 (15.9)	28.4 (8.3)	.26	1.90 (0.12)	3.9 (11.6)	210	210	210
	3C1H	453 (214)	13.5 (4.0)	9.7 (2.9)	2.84 (0.18)	13.0 (39.9)	16.9 (4.9)	.15	1.12 (0.07)	3.5 (10.3)	210	210	210
6	2C1H	780 (368)	17.0 (5.0)	13.3 (4.0)	3.62 (0.23)	17.9 (53.4)	27.9 (8.2)	.25	1.86 (0.12)	10.9 (32.6)	320	320	320
	2C2H	725 (342)	16.4 (4.8)	12.7 (3.7)	3.50 (0.22)	16.8 (50.1)	45.4 (13.3)	.41	3.03 (0.19)	10.9 (32.6)	320	320	320
	3C1H	725 (342)	19.3 (5.7)	14.7 (4.3)	4.08 (0.26)	6.9 (20.7)	26.8 (7.9)	.24	1.79 (0.11)	10.1 (30.3)	320	320	320
8	2C1H	886 (418)	18.1 (5.3)	15.0 (4.4)	3.85 (0.24)	5.5 (16.5)	34.0 (10.0)	.31	2.26 (0.14)	18.6 (55.5)	320	320	320
	2C2H	835 (394)	17.6 (5.1)	14.4 (4.2)	3.73 (0.24)	5.2 (15.5)	52.8 (15.5)	.48	3.52 (0.22)	4.3 (12.8)	320	320	320
	3C1H	835 (394)	23.8 (7.0)	17.3 (5.1)	4.98 (0.31)	11.1 (33.3)	32.8 (9.6)	.30	2.19 (0.14)	17.5 (52.2)	320	320	320
10	2C1H	1230 (580)	25.9 (7.6)	20.6 (6.0)	5.53 (0.35)	12.0 (35.8)	46.0 (13.5)	.42	3.06 (0.19)	38.4 (114.9)	530	530	530
	2C2H	1152 (544)	25.0 (7.3)	19.8 (5.8)	5.36 (0.34)	11.3 (33.7)	72.2 (21.2)	.66	4.81 (0.30)	8.4 (25.1)	530	530	530
	3C1H	1152 (544)	32.8 (9.6)	23.5 (6.9)	6.91 (0.44)	22.8 (68.1)	44.3 (13.0)	.40	2.95 (0.19)	36.0 (107.5)	530	530	530
12	2C1H	1315 (621)	30.6 (9.0)	23.5 (6.9)	6.48 (0.41)	17.2 (51.4)	51.4 (15.1)	.47	3.43 (0.22)	53.5 (160.0)	530	530	530
	2C2H	1274 (601)	30.1 (8.8)	23.0 (6.8)	6.37 (0.40)	16.7 (49.9)	82.3 (24.1)	.75	5.49 (0.35)	11.4 (34.1)	530	530	530
	3C1H	1274 (601)	36.9 (10.8)	26.9 (7.9)	7.74 (0.49)	17.5 (52.2)	50.5 (14.8)	.46	3.36 (0.21)	51.8 (154.8)	530	530	530

**Table PD-13. High Static Motor, Four-Pipe, Group 2**

FC	Coil	Cooling					Heating						
		Cfm (L/s)	TMBh (TkW)	SMBh (SkW)	Gpm (L/s)	WPD (kPa)	TMBh (TkW)	Q/ITD	Gpm (L/s)	WPD (kPa)	115V Watt	230V Watt	277V Watt
2	2C1H	250 (118)	5.5 (1.6)	4.3 (1.3)	1.20 (0.08)	7.8 (23.4)	9.1 (2.7)	.08	0.61 (0.04)	0.9 (2.6)	145	145	145
	2C2H	234 (111)	5.3 (1.6)	4.1 (1.2)	1.16 (0.07)	7.4 (22.0)	15.6 (4.6)	.14	1.04 (0.07)	4.7 (14.0)	145	145	145
	3C1H	234 (111)	7.6 (2.2)	5.4 (1.6)	1.63 (0.10)	20.1 (60.0)	8.8 (2.6)	.08	0.58 (0.04)	0.8 (2.5)	145	145	145
3	2C1H	309 (146)	6.8 (2.0)	5.2 (1.5)	1.46 (0.09)	12.3 (36.8)	11.6 (3.4)	.11	0.78 (0.05)	1.5 (4.5)	145	140	135
	2C2H	290 (137)	6.6 (1.9)	5.0 (1.5)	1.42 (0.09)	11.7 (34.8)	19.7 (5.8)	.18	1.31 (0.08)	7.9 (23.5)	145	140	135
	3C1H	290 (137)	8.0 (2.4)	6.0 (1.8)	1.70 (0.11)	4.6 (13.7)	11.2 (3.3)	.10	0.75 (0.05)	1.4 (4.3)	145	140	135
4	2C1H	440 (208)	9.5 (2.8)	7.7 (2.3)	2.03 (0.13)	5.2 (15.5)	16.6 (4.9)	.15	1.10 (0.07)	3.4 (10.0)	210	210	210
	2C2H	416 (196)	9.2 (2.7)	7.4 (2.2)	1.97 (0.12)	4.9 (14.7)	26.9 (7.9)	.24	1.79 (0.11)	3.5 (10.4)	210	210	210
	3C1H	416 (196)	12.9 (3.8)	9.2 (2.7)	2.72 (0.17)	12.1 (36.1)	16.0 (4.7)	.15	1.07 (0.07)	3.2 (9.4)	210	210	210
6	2C1H	704 (332)	16.2 (4.7)	12.5 (3.7)	3.45 (0.22)	16.4 (49.0)	26.4 (7.7)	.24	1.76 (0.11)	9.8 (29.4)	320	320	320
	2C2H	662 (312)	15.7 (4.6)	12.0 (3.5)	3.35 (0.21)	15.5 (46.4)	42.8 (12.5)	.40	2.85 (0.18)	9.8 (29.2)	320	320	320
	3C1H	662 (312)	18.3 (5.4)	13.9 (4.1)	3.88 (0.24)	6.3 (18.9)	25.4 (7.5)	.23	1.69 (0.11)	9.2 (27.6)	320	320	320
8	2C1H	815 (385)	17.4 (5.1)	14.2 (4.2)	3.69 (0.23)	5.1 (15.2)	32.3 (9.5)	.29	2.15 (0.14)	17.0 (50.8)	320	320	320
	2C2H	775 (366)	16.8 (4.9)	13.7 (4.0)	3.59 (0.23)	4.8 (14.5)	50.2 (14.7)	.46	3.34 (0.21)	3.9 (11.6)	320	320	320
	3C1H	775 (366)	22.9 (6.7)	16.5 (4.9)	4.80 (0.30)	10.4 (31.1)	31.3 (9.2)	.28	2.09 (0.13)	16.1 (48.1)	320	320	320
10	2C1H	1117 (527)	24.6 (7.2)	19.4 (5.7)	5.29 (0.33)	11.0 (32.9)	43.5 (12.7)	.40	2.90 (0.18)	34.8 (104.0)	530	530	530
	2C2H	1057 (499)	23.9 (7.0)	18.8 (5.5)	5.14 (0.32)	10.4 (31.2)	68.2 (20.0)	.62	4.55 (0.29)	7.5 (22.5)	530	530	530
	3C1H	1057 (499)	31.4 (9.2)	22.4 (6.7)	6.64 (0.42)	21.1 (63.2)	42.1 (12.3)	.38	2.80 (0.18)	32.9 (98.2)	530	530	530
12	2C1H	1242 (586)	29.7 (8.7)	22.7 (6.6)	6.31 (0.40)	16.4 (49.0)	49.7 (14.6)	.45	3.31 (0.21)	50.4 (150.7)	530	530	530
	2C2H	1181 (557)	29.0 (8.5)	22.0 (6.5)	6.15 (0.39)	15.6 (46.7)	78.2 (22.9)	.71	5.21 (0.33)	10.4 (31.0)	530	530	530
	3C1H	1181 (557)	35.5 (10.4)	25.6 (7.5)	7.45 (0.47)	16.2 (48.5)	48.2 (14.1)	.44	3.21 (0.20)	47.7 (142.7)	530	530	530

Note:

1. Cfm= Cubic feet per minute
2. TMBh = Total capacity (MBh)
3. Gpm = Gallons per minute
4. WPD = Water pressure drop (feet of water)
5. Q/ITD = MBh (kW)/(Entering water temperature - Entering air temperature) when ΔT and gpm (L/s) remain constant. To determine heating capacities at a different entering water temperature or entering air temp, compute the new ITD and multiply it by the Q/ITD shown.
6. Medium and low speed capacities are approximately 80% and 60% respectively of the high speed capacity.
7. High static motors need the appropriate length of duct to prevent poor acoustical applications.



# Performance Data

# Hot Water Reheat Coils

The following performance data represents the 1-row hot water and steam reheat coils that are available on fan-coil units in conjunction with a 2, 3, or 4-row cooling coil. Heating performance is based on 70°F (21°C) entering air temperature, 180°F (82°C) entering hot water temperature with a 20°F (-7°C) DT. All performance measured on high speed tap, 115 V, zero ESP, with a throwaway filter. See page 18 for performance groupings.

**Table PD-14. Hot Water Reheat Coil With Free Discharge Motor, Group 1**

FC	Main Coil Rows	TMBh (TkW)	Q/ITD	Gpm (L/s)	WPD (Pa)
02	2	2.9 (.8)	0.03	0.3 (.02)	0.01 (30)
	3	2.8 (.8)	0.03	0.3 (.02)	0.01 (30)
	4	2.7 (.8)	0.02	0.3 (.02)	0.01 (30)
03	2	4.1 (1.2)	0.04	0.4 (.03)	0.02 (60)
	3	4.0 (1.2)	0.04	0.4 (.03)	0.02 (60)
	4	3.8 (1.1)	0.04	0.4 (.03)	0.02 (60)
04	2	5.6 (1.6)	0.05	0.6 (.04)	0.04 (120)
	3	5.6 (1.6)	0.05	0.6 (.04)	0.04 (120)
	4	5.3 (1.6)	0.05	0.5 (.03)	0.03 (90)
06	2	9.3 (2.7)	0.09	0.9 (.06)	0.10 (299)
	3	9.3 (2.7)	0.09	0.9 (.06)	0.10 (299)
	4	8.9 (2.6)	0.08	0.9 (.06)	0.09 (269)
08	2	12.5 (3.7)	0.11	1.2 (.08)	0.18 (538)
	3	11.9 (3.5)	0.11	1.2 (.08)	0.17 (508)
	4	11.4 (3.3)	0.10	1.1 (.07)	0.16 (478)
10	2	16.1 (4.7)	0.15	1.6 (.10)	0.32 (957)
	3	16.2 (4.7)	0.15	1.6 (.10)	0.32 (957)
	4	15.6 (4.6)	0.14	1.6 (.10)	0.30 (897)
12	2	18.8 (5.5)	0.17	1.9 (.12)	0.45 (1350)
	3	18.5 (5.4)	0.17	1.8 (.11)	0.44 (1320)
	4	17.8 (5.2)	0.16	1.8 (.11)	0.40 (1200)

**Table PD-15. Hot Water Reheat Coil With Free Discharge Motor, Group 2**

FC	Main Coil Rows	TMBh (TkW)	Q/ITD	Gpm (L/s)	WPD (Pa)
02	2	2.7 (.8)	0.03	0.3 (.02)	0.01 (30)
	3	2.6 (.8)	0.02	0.3 (.02)	0.01 (30)
	4	2.5 (.7)	0.02	0.3 (.02)	0.01 (30)
03	2	3.8 (1.1)	0.03	0.4 (.03)	0.02 (60)
	3	3.7 (1.1)	0.03	0.4 (.03)	0.02 (60)
	4	3.6 (1.1)	0.03	0.4 (.03)	0.02 (60)
04	2	5.3 (1.6)	0.05	0.5 (.03)	0.03 (90)
	3	5.2 (1.5)	0.05	0.5 (.03)	0.03 (90)
	4	5.0 (1.5)	0.05	0.5 (.03)	0.03 (90)
06	2	8.8 (2.6)	0.08	0.9 (.06)	0.09 (269)
	3	8.7 (2.5)	0.08	0.9 (.06)	0.09 (269)
	4	8.5 (2.5)	0.08	0.8 (.05)	0.08 (239)
08	2	11.7 (3.4)	0.11	1.2 (.08)	0.17 (508)
	3	11.2 (3.3)	0.10	1.1 (.07)	0.15 (448)
	4	10.9 (3.2)	0.10	1.1 (.07)	0.15 (448)
10	2	15.2 (4.5)	0.14	1.5 (.09)	0.29 (867)
	3	15.2 (4.5)	0.14	1.5 (.09)	0.29 (867)
	4	14.8 (4.3)	0.13	1.5 (.09)	0.27 (807)
12	2	17.7 (5.2)	0.16	1.8 (.11)	0.40 (1200)
	3	17.4 (5.1)	0.16	1.7 (.11)	0.39 (1170)
	4	16.9 (5.0)	0.15	1.7 (.11)	0.37 (1110)

Note:

1. Medium and low speed capacities are approximately 80% and 60% respectively of the high speed capacity.
2. Q/ITD = MBh (kW)/(Entering water temperature - Entering air temperature) when ΔT and gpm (L/s) remain constant. To determine heating capacities at a different entering water temperature or entering air temperature, compute the new ITD and multiply it by the Q/ITD shown.



# Performance Data

# Hot Water Reheat Coils

The following performance data represents the 1-row hot water and steam reheat coils that are available on fan-coil units in conjunction with a 2, 3, or 4-row cooling coil. Heating performance is based on 70°F (21°C) entering air temperature, 180°F (82°C) entering hot water temperature with a 20°F (-7°C) ΔT. All performance measured on high speed tap, 115 V, zero ESP, with a throwaway filter. See page 18 for performance groupings.

**Table PD-16. Hot Water Reheat Coil With Free Discharge Motor, Group 3**

FC	Main Coil Rows	TMBh (TkW)	Q/ITD	Gpm (L/s)	WPD (Pa)
	2	2.6 (.8)	0.02	0.3 (.02)	0.01 (30)
02	3	2.5 (.7)	0.02	0.3 (.02)	0.01 (30)
	4	2.4 (.7)	0.02	0.3 (.02)	0.01 (30)
	2	3.6 (1.1)	0.03	0.4 (.03)	0.02 (60)
03	3	3.6 (1.1)	0.03	0.4 (.03)	0.02 (60)
	4	3.5 (1.0)	0.03	0.4 (.03)	0.01 (30)
	2	5.1 (1.5)	0.05	0.5 (.03)	0.03 (90)
04	3	5.0 (1.5)	0.05	0.5 (.03)	0.03 (90)
	4	4.9 (1.4)	0.04	0.5 (.03)	0.03 (90)
	2	8.4 (2.5)	0.08	0.8 (.05)	0.08 (239)
06	3	8.3 (2.4)	0.08	0.8 (.05)	0.08 (239)
	4	8.1 (2.4)	0.07	0.8 (.05)	0.08 (239)
	2	11.2 (3.3)	0.10	1.1 (.07)	0.15 (448)
08	3	10.8 (3.2)	0.10	1.1 (.07)	0.15 (448)
	4	10.5 (3.1)	0.10	1.1 (.07)	0.14 (419)
	2	14.5 (4.2)	0.13	1.5 (.09)	0.26 (777)
10	3	14.6 (4.3)	0.13	1.5 (.09)	0.27 (807)
	4	14.2 (4.2)	0.13	1.4 (.09)	0.25 (748)
	2	17.0 (5.0)	0.15	1.7 (.11)	0.37 (1110)
12	3	16.7 (4.9)	0.15	1.7 (.11)	0.36 (108)
	4	16.3 (4.8)	0.15	1.6 (.10)	0.34 (1020)

**Table PD-17. Hot Water Reheat Coil With High Static Motor, Group 1**

FC	Main Coil Rows	TMBh (TkW)	Q/ITD	Gpm (L/s)	WPD (Pa)
	2	3.2 (.9)	0.03	0.3 (.02)	0.01 (30)
02	3	3.2 (.9)	0.03	0.3 (.02)	0.01 (30)
	4	3.0 (.9)	0.03	0.3 (.02)	0.01 (30)
	2	4.5 (1.3)	0.04	0.5 (.03)	0.02 (60)
03	3	4.3 (1.3)	0.04	0.4 (.03)	0.02 (60)
	4	4.1 (1.2)	0.04	0.4 (.03)	0.02 (60)
	2	5.9 (1.7)	0.05	0.6 (.04)	0.04 (120)
04	3	6.5 (1.9)	0.06	0.7 (.04)	0.05 (150)
	4	6.3 (1.8)	0.06	0.6 (.04)	0.04 (120)
	2	10.1 (3.0)	0.09	1.0 (.06)	0.12 (359)
06	3	11.0 (3.2)	0.10	1.1 (.07)	0.14 (419)
	4	10.6 (3.1)	0.10	1.1 (.07)	0.13 (389)
	2	13.8 (4.0)	0.13	1.4 (.09)	0.22 (658)
08	3	13.6 (4.0)	0.12	1.4 (.09)	0.22 (658)
	4	13.2 (3.9)	0.12	1.3 (.08)	0.21 (628)
	2	17.8 (5.2)	0.16	1.8 (.11)	0.38 (1140)
10	3	18.8 (5.5)	0.17	1.9 (.12)	0.42 (1260)
	4	18.1 (5.3)	0.17	1.8 (.11)	0.40 (1200)
	2	20.8 (6.1)	0.19	2.1 (.13)	0.54 (1620)
12	3	21.3 (6.2)	0.19	2.1 (.13)	0.57 (1700)
	4	20.8 (6.1)	0.19	2.1 (.13)	0.54 (1620)

Note:

1. Medium and low speed capacities are approximately 80% and 60% respectively of the high speed capacity.
2. Q/ITD = MBh (kW)/(Entering water temperature - Entering air temperature) when ΔT and gpm (L/s) remain constant. To determine heating capacities at a different entering water temperature or entering air temperature, compute the new ITD and multiply it by the Q/ITD shown.
3. High static motors need the appropriate length of duct to prevent poor acoustical applications.



# Performance Data

# Hot Water Reheat Coils

Heating performance is based on 70°F (21°C) entering air temperature, 180°F (82°C) entering hot water temperature with a 20°F (-7°C) ΔT.  
 All performance measured on high speed tap, 115 V, 0.2" (.5 cm) ESP, with no filter.  
 See page 18 for performance groupings.

**Table PD-18. Hot Water Reheat Coil With High Static Motor, Group 2**

FC	Main Coil Rows	TMBh (TkW)	Q/ITD	Gpm (L/s)	WPD (Pa)
02	2	3.1 (.9)	0.03	0.3 (.02)	0.01 (30)
	3	3.0 (.9)	0.03	0.3 (.02)	0.01 (30)
	4	2.9 (.8)	0.03	0.3 (.02)	0.01 (30)
03	2	4.3 (1.3)	0.04	0.4 (.03)	0.02 (60)
	3	4.0 (1.2)	0.04	0.4 (.03)	0.02 (60)
	4	3.9 (1.1)	0.04	0.4 (.03)	0.02 (60)
04	2	5.6 (1.6)	0.05	0.6 (.04)	0.04 (120)
	3	6.1 (1.8)	0.06	0.6 (.04)	0.04 (120)
	4	6.0 (1.8)	0.05	0.6 (.04)	0.04 (120)
06	2	9.6 (2.8)	0.09	1.0 (.06)	0.11 (329)
	3	10.3 (3.0)	0.09	1.0 (.06)	0.11 (329)
	4	10.0 (2.9)	0.09	1.0 (.06)	0.12 (359)
08	2	13.2 (3.9)	0.12	1.3 (.08)	0.20 (598)
	3	13.0 (3.8)	0.12	1.3 (.08)	0.20 (598)
	4	12.7 (3.7)	0.12	1.3 (.08)	0.19 (568)
10	2	17.0 (5.0)	0.16	1.7 (.11)	0.35 (1050)
	3	17.7 (5.2)	0.16	1.8 (.11)	0.38 (1140)
	4	17.2 (5.0)	0.16	1.7 (.11)	0.36 (108)
12	2	19.9 (5.8)	0.18	2.0 (.13)	0.50 (1500)
	3	20.4 (6.0)	0.19	2.0 (.13)	0.52 (1560)
	4	19.9 (5.8)	0.18	2.0 (.13)	0.50 (1500)

**Table PD-19. Hot Water Reheat Coil With High Static Motor, Group 3**

FC	Main Coil Rows	TMBh (TkW)	Q/ITD	Gpm (L/s)	WPD (Pa)
02	2	2.9 (.8)	0.03	0.3 (.02)	0.01 (30)
	3	2.8 (.8)	0.03	0.3 (.02)	0.01 (30)
	4	2.7 (.8)	0.03	0.3 (.02)	0.01 (30)
03	2	4.1 (1.2)	0.04	0.4 (.03)	0.02 (60)
	3	3.9 (1.1)	0.04	0.4 (.03)	0.02 (60)
	4	3.8 (1.1)	0.03	0.4 (.03)	0.02 (60)
04	2	5.5 (1.6)	0.05	0.6 (.04)	0.03 (90)
	3	5.9 (1.7)	0.05	0.6 (.04)	0.04 (120)
	4	5.8 (1.7)	0.05	0.6 (.04)	0.04 (120)
06	2	9.2 (2.7)	0.08	1.0 (.06)	0.10 (299)
	3	9.9 (2.9)	0.09	1.0 (.06)	0.11 (329)
	4	9.7 (2.8)	0.09	1.0 (.06)	0.11 (329)
08	2	12.7 (3.7)	0.12	1.3 (.08)	0.19 (568)
	3	12.5 (3.7)	0.11	1.3 (.08)	0.19 (568)
	4	12.3 (3.6)	0.11	1.2 (.08)	0.18 (538)
10	2	16.4 (4.8)	0.15	1.6 (.10)	0.33 (987)
	3	17.0 (5.0)	0.15	1.7 (.11)	0.35 (1050)
	4	16.6 (4.9)	0.15	1.7 (.11)	0.34 (1020)
12	2	19.2 (5.6)	0.18	1.9 (.12)	0.47 (1400)
	3	19.6 (5.7)	0.18	2.0 (.13)	0.49 (1460)
	4	19.2 (5.6)	0.17	1.9 (.12)	0.47 (1400)

Note:

1. Medium and low speed capacities are approximately 80% and 60% respectively of the high speed capacity.
2. Q/ITD = MBh (kW)/(Entering water temperature - Entering air temperature) when ΔT and gpm (L/s) remain constant. To determine heating capacities at a different entering water temperature or entering air temperature, compute the new ITD and multiply it by the Q/ITD shown.
3. High static motors need the appropriate length of duct to prevent poor acoustical applications.



# Performance Data

# Steam Reheat Coils

**Table PD-20. Steam Properties**

Steam Pressure PSIG (kPa)	2 (14)	5 (34)	10 (69)	15 (103)
Sat. Steam Temp. F (C)	219 (104)	227 (108)	239 (115)	250 (121)
Latent Heat — BTU/LB. (kJ/kg)	965 (2240)	960 (2230)	952 (2210)	945 (2200)

Heating performance is based on 70°F (21°C) entering air temperature, 2 psig (14 kPa) and 5 psig (103 kPa) entering steam pressure. All performance measured on high speed tap, 115 V, zero ESP, with a throwaway filter.

**Table PD-21. Steam Reheat Coil With Free Discharge Motor, Group 1**

FC	Main Coil Rows	2 psig (14 kPa)	5 psig (103 kPa)	Q/ITD
		TMBh (TkW)	TMBh (TkW)	
02	2	5.3 (2)	5.6 (2)	0.04
	3	5.5 (2)	5.9 (2)	0.04
	4	5.0 (1)	5.3 (2)	0.03
03	2	6.8 (2)	7.2 (2)	0.05
	3	6.7 (2)	7.1 (2)	0.05
	4	6.4 (2)	6.8 (2)	0.04
04	2	8.7 (3)	9.2 (3)	0.06
	3	8.6 (3)	9.1 (3)	0.06
	4	8.2 (2)	8.7 (3)	0.06
06	2	13.4 (4)	14.2 (4)	0.09
	3	13.4 (4)	14.2 (4)	0.09
	4	12.8 (4)	13.6 (4)	0.09
08	2	17.4 (5)	18.5 (5)	0.12
	3	16.7 (5)	17.7 (5)	0.11
	4	16.0 (5)	16.9 (5)	0.11
10	2	21.7 (6)	23.0 (7)	0.15
	3	21.8 (6)	23.1 (7)	0.15
	4	21.0 (6)	22.2 (7)	0.14
12	2	25.1 (7)	26.6 (8)	0.17
	3	24.7 (7)	26.2 (8)	0.17
	4	23.8 (7)	25.2 (7)	0.16

**Table PD-22. Steam Reheat Coil With Free Discharge Motor, Group 2**

FC	Main Coil Rows	2 psig (14 kPa)	5 psig (103 kPa)	Q/ITD
		TMBh (TkW)	TMBh (TkW)	
02	2	5.0 (1)	5.3 (2)	0.03
	3	4.8 (1)	5.1 (1)	0.03
	4	4.6 (1)	4.9 (1)	0.03
03	2	6.4 (2)	6.8 (2)	0.04
	3	6.3 (2)	6.6 (2)	0.04
	4	6.1 (2)	6.5 (2)	0.04
04	2	8.2 (2)	8.7 (3)	0.06
	3	8.1 (2)	8.5 (2)	0.05
	4	7.8 (2)	8.3 (2)	0.05
06	2	12.6 (4)	13.4 (4)	0.09
	3	12.6 (4)	13.3 (4)	0.09
	4	12.2 (4)	12.9 (4)	0.08
08	2	16.5 (5)	17.4 (5)	0.11
	3	15.8 (5)	16.7 (5)	0.11
	4	15.3 (4)	16.2 (5)	0.10
10	2	20.6 (6)	21.8 (6)	0.14
	3	20.6 (6)	21.8 (6)	0.14
	4	20.0 (6)	21.1 (6)	0.14
12	2	23.7 (7)	25.1 (7)	0.16
	3	23.4 (7)	24.7 (7)	0.16
	4	22.7 (7)	24.0 (7)	0.15

Note:

1. Medium and low speed capacities are approximately 80% and 60% respectively of the high speed capacity.
2. Q/ITD = MBh (kW)/(Saturated steam temperature - Entering air temperature). To determine heating capacities at different entering steam pressure or entering air temperature, compute the new ITD and multiply it by the Q/ITD shown. (See the Steam Properties table at the end of this section to determine the saturated steam temperatures at various entering steam pressures.)



# Performance Data

# Steam Reheat Coils

Heating performance is based on 70°F (21°C) entering air temperature, 2 psig (14 kPa) and 5 psig (103 kPa) entering steam pressure. All performance measured on high speed tap, 115 V, zero ESP, with a throwaway filter.

**Table PD-23. Steam Reheat Coil With Free Discharge Motor, Group 3**

FC	Main Coil Rows	2 psig	5 psig	Q/ITD
		(14 kPa) TMBh (TkW)	(103 kPa) TMBh (TkW)	
02	2	4.7 (1)	5.0 (1)	0.03
	3	4.6 (1)	4.8 (1)	0.03
	4	4.4 (1)	4.7 (1)	0.03
03	2	6.1 (2)	6.5 (2)	0.04
	3	6.0 (2)	6.4 (2)	0.04
	4	5.8 (2)	6.2 (2)	0.04
04	2	7.9 (2)	8.3 (2)	0.05
	3	7.7 (2)	8.2 (2)	0.05
	4	7.6 (2)	8.0 (2)	0.05
06	2	12.1 (4)	12.8 (4)	0.08
	3	12.0 (4)	12.7 (4)	0.08
	4	11.7 (3)	12.4 (4)	0.08
08	2	15.7 (5)	16.6 (5)	0.11
	3	15.2 (4)	16.1 (5)	0.10
	4	14.8 (4)	15.7 (5)	0.10
10	2	19.7 (6)	20.8 (6)	0.13
	3	19.7 (6)	20.9 (6)	0.13
	4	19.2 (6)	20.3 (6)	0.13
12	2	22.7 (7)	24.1 (7)	0.15
	3	22.4 (7)	23.8 (7)	0.15
	4	21.8 (6)	23.1 (7)	0.15

**Table PD-24. Steam Reheat Coil With High Static Motor, Group 1**

FC	Main Coil Rows	2 psig	5 psig	Q/ITD
		(14 kPa) TMBh (TkW)	(103 kPa) TMBh (TkW)	
02	2	6.0 (2)	6.3 (2)	0.04
	3	5.9 (2)	6.2 (2)	0.04
	4	5.6 (2)	5.9 (2)	0.04
03	2	7.6 (2)	8.0 (2)	0.05
	3	7.2 (2)	7.7 (2)	0.05
	4	7.0 (2)	7.4 (2)	0.05
04	2	9.1 (3)	9.6 (3)	0.06
	3	10.1 (3)	10.7 (3)	0.07
	4	9.7 (3)	10.3 (3)	0.07
06	2	14.6 (4)	15.4 (5)	0.10
	3	15.8 (5)	16.7 (5)	0.11
	4	15.2 (4)	16.1 (5)	0.10
08	2	19.3 (6)	20.5 (6)	0.13
	3	19.0 (6)	20.1 (6)	0.13
	4	18.5 (5)	19.6 (6)	0.13
10	2	24.0 (7)	25.4 (7)	0.16
	3	25.3 (7)	26.8 (8)	0.17
	4	24.4 (7)	25.9 (8)	0.17
12	2	27.8 (8)	29.5 (9)	0.19
	3	28.5 (8)	30.2 (9)	0.19
	4	27.8 (8)	29.4 (9)	0.19

Note:

1. Medium and low speed capacities are approximately 80% and 60% respectively of the high speed capacity.
2. Q/ITD = MBh (kW)/(Saturated steam temperature - Entering air temperature). To determine heating capacities at different entering steam pressure or entering air temperature, compute the new ITD and multiply it by the Q/ITD shown. (See the Steam Properties table at the end of this section to determine the saturated steam temperatures at various entering steam pressures.)



# Performance Data

# Steam Reheat Coils

Heating performance is based on 70°F (21°C) entering air temperature, 2 psig (14 kPa) and 5 psig (103 kPa) entering steam pressure. All performance measured on high speed tap, 115 V, 0.2" (.5 cm) ESP, with no filter.

**Table PD-25. Steam Reheat Coil With High Static Motor, Group 2**

FC	Main Coil Rows	2 psig	5 psig	Q/ITD
		(14 kPa) TMBh (TkW)	(103 kPa) TMBh (TkW)	
02	2	5.6 (2)	6.0 (2)	0.04
	3	5.5 (2)	5.8 (2)	0.04
	4	5.3 (2)	5.6 (2)	0.04
03	2	7.2 (2)	7.6 (2)	0.05
	3	6.8 (2)	7.2 (2)	0.05
	4	6.6 (2)	7.0 (2)	0.05
04	2	8.7 (3)	9.2 (3)	0.06
	3	9.5 (3)	10.1 (3)	0.06
	4	9.3 (3)	9.8 (3)	0.06
06	2	13.8 (4)	14.6 (4)	0.09
	3	14.9 (4)	15.7 (5)	0.10
	4	14.4 (4)	15.3 (4)	0.10
08	2	18.4 (5)	19.5 (6)	0.12
	3	18.2 (5)	19.2 (6)	0.12
	4	17.7 (5)	18.8 (6)	0.12
10	2	23.0 (7)	24.3 (7)	0.16
	3	23.9 (7)	25.3 (7)	0.16
	4	23.2 (7)	24.6 (7)	0.16
12	2	26.6 (8)	28.2 (8)	0.18
	3	27.3 (8)	28.9 (8)	0.18
	4	26.6 (8)	28.2 (8)	0.18

**Table PD-26. Steam Reheat Coil With High Static Motor, Group 3**

FC	Main Coil Rows	2 psig	5 psig	Q/ITD
		(14 kPa) TMBh (TkW)	(103 kPa) TMBh (TkW)	
02	2	5.4 (2)	5.7 (2)	0.04
	3	5.2 (2)	5.5 (2)	0.04
	4	5.1 (1)	5.4 (2)	0.03
03	2	6.9 (2)	7.3 (2)	0.05
	3	6.6 (2)	6.9 (2)	0.04
	4	6.4 (2)	6.8 (2)	0.04
04	2	8.5 (2)	8.9 (3)	0.06
	3	9.2 (3)	9.7 (3)	0.06
	4	9.0 (3)	9.5 (3)	0.06
06	2	13.3 (4)	14.1 (4)	0.09
	3	14.2 (4)	15.1 (4)	0.10
	4	13.9 (4)	14.7 (4)	0.09
08	2	17.8 (5)	18.8 (6)	0.12
	3	17.5 (5)	18.5 (5)	0.12
	4	17.2 (5)	18.2 (5)	0.12
10	2	22.2 (7)	23.5 (7)	0.15
	3	22.9 (7)	24.2 (7)	0.15
	4	22.4 (7)	23.7 (7)	0.15
12	2	25.7 (8)	27.2 (8)	0.17
	3	26.2 (8)	27.8 (8)	0.18
	4	25.7 (8)	27.2 (8)	0.17

- Note:
1. Medium and low speed capacities are approximately 80% and 60% respectively of the high speed capacity.
  2. Q/ITD = MBh (kW)/(Saturated steam temperature - Entering air temperature). To determine heating capacities at different entering steam pressure or entering air temperature, compute the new ITD and multiply it by the Q/ITD shown. (See the Steam Properties table at the end of this section to determine the saturated steam temperatures at various entering steam pressures.)
  3. High static motors need the appropriate length of duct to prevent poor acoustical applications.

# Controls

## Control Options

UniTrane® fan-coils are available with four different control options:

- Manual three-speed fan switch
- Tracer ZN010
- Tracer ZN510
- Tracer ZN520

## Manual Fan Mode Switch

### Model Number Digit 30 = A and Digit 31 = D or K

The manual fan mode switch is available for fan-coil units that do not have Trane factory-mounted control packages. This four-position switch (off, high, medium, low) allows manual fan mode selection and is available unit or wall mounted. The unit-mounted option (Digit 31 = D) operates on line voltage. The wall-mounted option (Digit 31 = K) is low-voltage and has three 24 volt relays using a factory-wired transformer and relays to control the fan motor.



**Fan Speed Switch**

## Tracer® Controls

The Tracer family of controllers, ZN010; ZN510; and ZN520, offer the combined advantages of simple and dependable operation with the latest Trane-designed controller. Standard control features include options normally available on more elaborate control systems. All control options are available factory-configured or can be field-configured using Rover™ service software. For more detailed information, refer to the Trane publication, *CNT-IOP-1* or *CNT-IOP-2*.

### Tracer ZN010

#### Model Number Digit 30 = E

Tracer ZN010 is a stand-alone microprocessor controller.

### Tracer ZN510

#### Model Number Digit 30 = F

ZN510 can be used as either a stand-alone or communicating microprocessor controller.

### Tracer ZN520

#### Model Number Digit 30 = G

The ZN520 controller can be used in a stand-alone application or as part of a Trane Integrated Comfort™ System (ICS).

In the stand-alone configuration, ZN520 receives operation commands from the zone sensor and/or the auto changeover sensor (on auto changeover units). The entering water temperature is read from the auto changeover sensor and determines if the unit is capable of cooling or heating. The zone sensor module is capable of transmitting the following information to the controller:

- Timed override on/cancel request
- Zone setpoint
- Current zone temperature
- Fan mode selection (off-auto-high-med-low)

For optimal system performance, fan-coil units can operate as part of an Integrated Comfort™ System (ICS) building automation system controlled by Tracer Summit®. The controller is linked directly to the Summit control panel via a twisted pair communication wire, requiring no additional interface device (i.e., a command unit). The Trane ICS system can monitor or override ZN520 control points. This includes such points as temperature and output positions.

### Rover™ Service Software

This windows-based software package option allows field service personnel to easily monitor, save, download, and configure Tracer controllers through a communication link from a portable computer. When connected to the communication link, Rover can view any Tracer controller that is on the same communication link.



**Tracer ZN010 Control Board**

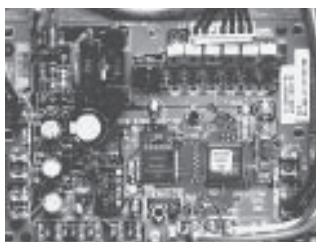

**Tracer ZN510 Control Board**

# Controls

# Sequence of Operation

## Sequence of Operation

### Fan Speed Switch

Off: Fan is turned off, two-position damper option spring-returns closed.

High, Medium, Low: Fan runs continuously at the selected speed. The two-position damper option opens to an adjustable mechanical stop-position.

### Tracer ZN010 and ZN510

Off: Fan is off; control valves and fresh air damper option close. Low air temperature detection option is still active.

Auto (Fan Cycling): Fan and fresh air damper cycle with control valve option to maintain setpoint temperature. In cooling mode, the fan cycles from off to medium and in heating mode it cycles from off to low (factory default that can be field-adjusted using Rover service software). When no heating or cooling is required, the fan is off and the fresh air damper option closes. The fan can also be field-configured (using Rover) to run at a defined speed when the fan speed switch is in the auto position.

Low, Medium, High (Continuous Fan): Fan operates continuously while control valve

option cycles to maintain setpoint temperature. Fresh air damper option is open.

### Tracer ZN520

Off: Fan is off; control valve options and fresh air damper options close. The low air temperature detection option is still active.

Auto: Fan speed control in the auto setting allows the modulating (three-wire floating point) control valve option and three-speed fan to work cooperatively to meet precise capacity requirements, while minimizing fan speed (motor/energy/acoustics) and valve position (pump energy/chilled water reset). As the capacity requirement increases at low fan speed, the water valve opens. When the low fan speed capacity switch point is reached, the fan switches to medium speed and the water valve repositions to maintain an equivalent capacity. The reverse sequence takes place with a decrease in required capacity.

Low, Medium, High: The fan will run continuously at the selected speed and the valve option will cycle to meet setpoint.



# General Information

## Controls

**Table C-1. Controller Input/Output Summary**

	ZN010	ZN510	ZN520
<b>Binary Outputs</b>			
3-Speed Fan	✓	✓	✓
2-Position Hydronic Valve	✓	✓	✓
2-Position Fresh Air Damper	✓	✓	
1-Stage Electric Heat	✓	✓	✓
3-Wire Economizer Damper			✓
3-Wire Hydronic Valve			✓
2-Stage Electric Heat			✓
Reheat (hydronic or electric)			✓
Generic	✓	✓	✓
<b>Binary Inputs</b>			
Condensate Overflow Detection	✓	✓	✓
Low Temperature Detection	✓	✓	✓
Occupancy	✓	✓	✓
Generic Input	✓	✓	✓
<b>Analog Inputs</b>			
Zone Temperature	✓	✓	✓
Setpoint	✓	✓	✓
Fan Mode: Auto, High, Medium, Low	✓	✓	✓
Entering Water	✓	✓	✓
Discharge Air	✓	✓	✓
Outside Air			✓
Generic			✓

Note: The generic input and output are for use with a Tracer Summit system only.

**Table C-2. Controller Function Summary**

	ZN010	ZN510	ZN520
<b>Control Functions</b>			
Entering Water Temp. Sampling (Purge)	✓	✓	✓
Timed Override	✓	✓	✓
Auto Changeover	✓	✓	✓
Fan Cycling	✓	✓	
Warm-Up	✓	✓	✓
Pre-Cool	✓	✓	✓
Data Sharing (Master/Slave)		✓	✓
Random Start	✓	✓	✓
Dehumidification			✓
Staged Capacity (2-Stage Electric Supplementary)			✓
<b>Other Functions</b>			
Manual Test	✓	✓	✓
Maintenance Timer	✓	✓	✓
Setpoint Limits	✓	✓	✓

# Controls

# Zone Sensor Options

## Zone Sensor Options

Zone sensors are available as either unit, wall, or split-mounted options for design flexibility. Fan-coils with the unit-mounted zone sensor option include a thermistor in the unit's return air path. Wall-mounted zone sensor options have an internal thermistor. Zone sensors operate on 24 VAC.

### Tracer ZN010 Options



*Unit-mounted zone sensor: Digit 30 = E and Digit 31 = V*

### Tracer ZN510 and ZN520 Options



*Wall-mounted zone sensor: Digit 30 = F or G and Digit 31 = 1*



*Wall-mounted zone sensor: Digit 30 = E and Digit 31 = W*



*Wall-mounted zone sensor: Digit 30 = F or G and Digit 31 = 2*



*Split-mounted zone sensor, unit-mounted fan mode and wall-mounted setpoint dial: Digit 30 = E and Digit 31 = X*



*Split-mounted zone sensor, unit-mounted fan mode and wall-mounted setpoint dial: Digit 30 = F or G and Digit 31 = Y*



*Unit-mounted zone sensor: Digit 30 = F or G and Digit 31 = Z*

## Controls

## Features

### Control Features

The following control functions are standard features on units with Tracer ZN010, ZN510, or ZN520.

#### Entering Water Temperature Sampling Function

A system that uses a two-way control valve option might not sense the correct entering water temperature during long periods when the control valve is closed. If the demand for heating or cooling does not exist for a long period, the entering water will eventually approach ambient temperature.

Using the entering water temperature sampling function, the controller provides accurate two-pipe system changeover—without sacrificing the benefits of two-way control valves. Also, it eliminates inefficient bleed or bypass lines that can allow unnecessary waterflow through the system.

This function periodically samples the entering water temperature by opening the hydronic valve. The valve opens for 20 seconds to allow the water temperature to stabilize. Then the controller reads the entering water temperature for up to three minutes to see if the correct water temperature is available for the selected operating mode.

The entering water temperature must be five degrees or more above the space temperature to allow hydronic heating and five degrees or more below the space temperature to allow hydronic cooling. If the correct water temperature for the operating mode is available, the unit begins normal heating or cooling operation. If the correct water temperature is not available, the controller closes the control valve and waits 60 minutes before attempting to sample the entering water temperature again.

A factory-mounted thermistor senses the entering water temperature on changeover cooling/heating coil units. If the fan-coil has a factory-mounted piping package, the sensor is strapped to the entering water pipe. If the fan-coil does not have a piping package, the sensor is coiled in the end pocket for mounting on customer-supplied piping. This sensor must detect accurate water temperature for proper changeover.

#### Automatic Heat/Cool Mode Determination

The controller automatically determines whether heating or cooling is needed—based on space and system conditions. Utilizing a proportional/integral (PI) control algorithm to maintain the space temperature at the active heating or cooling setpoint. The controller measures the space temperature and active setpoint temperature to determine the unit's heating or cooling capacity (zero to 100%).

#### Occupied/Unoccupied Operation

The occupancy input utilizes a binary switch (i.e. motion sensor, timeclock, etc.) that allows the zone sensor to utilize its unoccupied internal setpoints.

#### Random Start

This feature randomly staggers multiple unit start-up to reduce electrical demand spikes.

#### Warm-up

The two-position fresh air damper option closes during the occupied mode when the space temperature is three degrees or more below the heating setpoint temperature. The damper remains closed during warm-up until the space temperature is within two degrees of the heating setpoint temperature.

#### Cool-down

The two-position fresh air damper option closes during the occupied mode when the space temperature is three degrees or more above the cooling setpoint temperature. The damper remains closed during cool-down until the space temperature is within two degrees of the cooling setpoint temperature.

#### Manual Output Test Function

This feature is an invaluable tool for troubleshooting a unit. By simply pressing the controller's test button, service personnel can manually exercise outputs in a pre-defined sequence.

#### Peer to Peer Communication (Tracer ZN510 and ZN520)

Peer to peer communication allows multiple units in one space to share the same zone sensor and provide simultaneous heating and cooling. Tracer ZN510 or ZN520 can share information between units on the same communication link

using a twisted pair wire in the field. Unit configuration must be modified with Rover service tool.

#### Economizing Control (Tracer ZN520)

With the controller configured for economizing control, it will calculate the required cooling capacity every ten seconds and modulate the damper option open to the calculated position. If the setpoint is not satisfied, the damper will continue to open until the setpoint condition has been met or the damper is 100% open. If this still does not satisfy the setpoint, the cooling valve option will begin to open and try to satisfy the load requirements. Once capacity exceeds the load requirements, the valve will begin to close until the setpoint has been reached or the damper reaches its minimum position, which is field-adjustable. This option uses a three-wire, floating point damper actuator.

A thermistor to sense discharge air is factory mounted near the discharge surface of the last coil for use in economizing and cascade temperature control. Tracer Summit® can also utilize this temperature value as a read-only point. Cascade temperature control uses both the zone and discharge air temperatures to more accurately calculate the required unit capacity.

A thermistor to sense fresh air is factory mounted at the unit's fresh air opening for use in economizer applications or as a read-only point for Tracer Summit. If the fresh air temperature is a read-only value, it will not impact the control algorithm. In an economizer application, a fresh air temperature signal must be provided either by this thermistor or Tracer Summit.



## Controls

## Features

### Tracer ZN520 Additional Features

#### Automatic Ventilation Reset

To ensure proper ventilation rates, the controller is configured with two fresh air damper minimum position setpoints for occupied operation. As the fan speed changes to low or high, the damper modulates to maintain the correct ventilation rate for the space. The damper position does not change when the fan speed changes to medium.

#### Fan Status

Tracer ZN520 monitors the fan output status to determine if the fan is operating.

#### Filter Maintenance Status

The controller has an adjustable timer that indicates through Summit or Rover when filter maintenance is necessary. Filter maintenance status is based on cumulative fan run hours.

#### Dehumidification

When the fan-coil unit is equipped with a reheat coil and humidity sensor, the controller will keep humidity levels within an acceptable range. This feature helps reduce the risk of microbial growth and damage to building interiors.

#### Water Valve Override

Using Summit or Rover, the water valve override function drives all water valves in every unit fully open simultaneously. This helps reduce the time required for waterside balancing.

#### Cascade Control

The controller maintains discharge air temperature using a cascade control algorithm. The discharge air temperature is based on the difference between the space temperature and setpoint. Unit capacity modulates to achieve the discharge air temperature.

#### Interoperability

Tracer ZN520 can be used with a Tracer Summit system or on other control systems that support LonTalk and the SCC profile. For more information on specific inputs and outputs, see the *Installation, Owner, and Maintenance Manual, UNT-IOM-6*.

## End Device Options

# Controls



*Control Valve*

### End Device Options

All end device options are factory-installed and tested.

#### Two-Position Control Valves

##### Model Number Digits 27 and 28 = A - H

Two-position valve options are available with either Tracer ZN010, ZN510, or ZN520. Valves are spring-return type, sweat connections, and available as normally open or closed. The valves respond to a 24V signal and have 1/2-inch sweat connections. The two-way valve option will either fully open or close. The three-way valve option allows either full water flow through the coil or diverts waterflow through the bypass. If the control valve loses power, the valve returns to its de-energized position. All control valve options are factory installed in the leaving water piping downstream of the hydronic coil. The valve actuator is easily removable for service without removing the valve body from piping.

#### Modulating Control Valves (Tracer ZN520)

##### Model Number Digits 27 and 28 = J - R

These 1/2-inch sweat connect valves are three-wire floating point valves, equal %age type. Modulating valves are available in four Cv sizes: 0.7, 1.5, 2.5, and 4.0. The valve responds to a 24V triac signal from the controller, which determines the valve position by a control algorithm. If the valve loses power, it

remains in the position that it was in when the power loss occurred. All control valves are factory installed in the leaving water piping downstream of the hydronic coil.

#### Field-Supplied Valves

##### Model Number Digits 27 and 28 = X or Y

When using field-supplied valves, this option allows the controller to be factory-configured for the normal position of the field-supplied valve.

Note: The Trane Company does not recommend wild coil applications.

#### Two-Position Fresh Air Damper Actuator

##### Model Number Digit 13 = D, E, or F (Available with all control options except ZN520)

This damper actuator uses a 24V signal and is factory-wired and mounted to the damper assembly. It allows zero to 50% fresh air. The damper will drive open to an adjustable mechanical stop-position whenever the fan is running during occupied mode and will spring-return closed when the fan turns off.

Note: Trane recommends using the low temperature detection option with fresh air dampers to detect possible freeze conditions.

## Controls

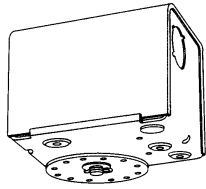

*Two-Position Fresh Air Damper Actuator*

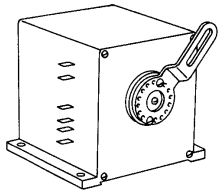

*Economizer Fresh Air Damper Actuator*



*Low Temperature Detection Device*



*Condensate Overflow Detection Device*

### **Economizer Fresh Air Damper Actuator (Tracer ZN520)**

#### **Model Number Digit 13 = G, H, or J**

This option is a three-wire floating point, spring-return damper actuator and is factory-wired and mounted to the damper assembly. When the controller enables the economizer and the unit is in occupied mode, the fresh air damper modulates between its minimum position (editable) and the full open position to maintain setpoint temperature. If economizer operation stops or if the unit is in the heating mode, the fresh air damper adjusts to its minimum position.

Note: Trane highly recommends using the low temperature detection option with a fresh air damper to detect possible freeze conditions.

#### **Low Temperature Detection**

##### **Model Number Digit 36 = 2**

When the low temperature detection device senses an entering air temperature of 36°F to the hydronic coil, the normally-closed switch opens a corresponding set of binary input terminals. The fan disables, control valves open, and the fresh air damper closes.

Thirty minutes after the diagnostic, Tracer ZN010, ZN510, or ZN520 uses an automatic reset function to attempt to reset the unit. If the diagnostic occurs again within 24 hours after an automatic diagnostic reset, the unit will require a manual reset. This function attempts to resolve the infrequent nuisance alarm.

The low temperature detection device is an averaging type capillary tube and will reset when it detects an entering air temperature of at least 44°F.

#### **Condensate Overflow Detection**

##### **Model Number Digit 35 = 2**

A float switch is factory-supplied for field installation in the auxiliary drain pan to detect a high condensate water level. When the float switch rises, the normally closed input opens a corresponding set of binary input terminals. This also causes the fan to disable, and the control valve and fresh air damper options to close. Although the float switch will close when the high condensate level recedes, the controller must be manually reset before normal unit operation can occur. If using a Tracer ZN510 or ZN520 controller you can reset using Tracer Summit. Use Rover service software to reset units with Tracer ZN010, ZN510, or ZN520.



# Electrical Data      Electric Heat

**Table ED-1. Electric Heat kW**

Unit Size	Unit Voltage	kW	kW	kW	kW	kW	kW	kW	kW	kW	kW	
02	115	1.0	1.5	2.0								
	230	1.0	1.5	2.0								
	277	1.0	1.5	2.0								
	208	0.8	1.1	1.5	1.9							
03	115	1.0	1.5	2.0	2.5							
	230	1.0	1.5	2.0	2.5							
	277	1.0	1.5	2.0	2.5							
	208	0.8	1.1	1.5	1.9	2.3						
04	115			2.0	2.5	3.0						
	230			2.0	2.5	3.0						
	277			2.0	2.5	3.0						
	208			1.5	1.9	2.3	3.0					
06	115			2.0		3.0						
	230			2.0		3.0	4.0	5.0	6.0			
	277			2.0		3.0	4.0	5.0	6.0			
	208			1.5		2.3	3.0	3.8	4.5	5.3		
08	115			2.0		3.0						
	230			2.0		3.0	4.0	5.0	6.0	7.0		
	277			2.0		3.0	4.0	5.0	6.0	7.0		
	208			1.5		2.3	3.0	3.8	4.5	5.3	6.0	
10	115					3.0						
	230					3.0	4.0	5.0	6.0	7.0	8.0	
	277					3.0	4.0	5.0	6.0	7.0	8.0	
	208					2.3	3.0	3.8	4.5	5.3	6.0	
12	115					3.0						
	230					3.0	4.0	5.0	6.0	7.0	8.0	10.0
	277					3.0	4.0	5.0	6.0	7.0	8.0	10.0
	208					2.3	3.0	3.8	4.5	5.3	6.0	

**Table ED-2. Electric Heat kW, Low Vertical Units**

Unit Size	Unit Voltage	kW	kW	kW	kW
03	115	1.0	1.5	2.0	
04	115	1.0	1.5	2.0	2.5
06	115	1.0	1.5	2.0	2.5

Low vertical units are only available with electric heat in combination with the two-row cooling coil.

**Minimum Circuit Ampacity (MCA) and Maximum Fuse Size (MFS) Calculations for Fan-Coils with Electric Heat (Single Phase)**

Heater Amps = (Heater kW x 1000)/Heater Voltage

Note: Use 120V heater voltage for 115V units. Use 240V heater voltage for 230V units.

MCA = 1.25 x (heater amps + all motor FLAs)

MFS or HACR Type Circuit Breaker = (2.25 x Largest Motor FLA) + Second Motor FLA + Heater Amps (If Applicable)

HACR (Heating, Air-Conditioning and Refrigeration) type circuit breakers are required in the branch circuit wiring for all fan-coils with electric heat.

See Tables ED- 3 through ED-6 for motor FLAs

Select a standard fuse size or HACR type circuit breaker equal to the MCA. Use the next larger standard size if the MCA does not equal a standard size.

Standard Fuse Sizes are: 15, 20, 25, 30, 35, 40, 45, 50, 60 amps

Fan-coil electric heat MBh = (Heater kW) (3.413)



# Electrical Data

**Table ED-3. Free Discharge Motors on Units with Two-Row Coils**

FC	115 Volt			208-230 Volt			277 Volt			RPM		
	FLA	HP (kW)		FLA	HP (kW)		FLA	HP (kW)		H	M	L
02	0.6	.03 (.02)		0.3	.03 (.02)		0.2	.03 (.02)		980	840	655
03	0.7	.04 (.02)		0.4	.04 (.02)		0.3	.04 (.02)		980	780	580
04	0.9	.05 (.04)		0.5	.05 (.04)		0.4	.05 (.04)		1050	780	580
06	1.2	.07 (.05)		0.6	.07 (.05)		0.5	.07 (.05)		1030	780	580
08	1.4	.12 (.09)		0.9	.12 (.09)		0.6	.12 (.09)		1080	800	600
10	0.9	1.2	.05 (.04) .07 (.05)	0.5	0.6	.05 (.04) .07 (.05)	0.4	0.5	.05 (.04) .07 (.05)	1050	780	580
										1030	780	580
12	0.9	1.4	.05 (.04) .12 (.09)	0.5	0.9	.05 (.04) .12 (.09)	0.4	0.6	.05 (.04) .12 (.09)	1050	780	580
										108	800	600

**Table ED-4. High Static Motors on Units with Two-Row Coils**

FC	115 Volt			208-230 Volt			277 Volt			RPM		
	FLA	HP (kW)		FLA	HP (kW)		FLA	HP (kW)		H	M	L
02	1.1	.07 (.05)		0.6	.07 (.05)		0.5	.07 (.05)		1480	1110	865
03	1.4	.08 (.06)		0.7	.08 (.06)		0.6	.08 (.06)		1400	1175	860
04	1.6	.10 (.07)		0.8	.10 (.07)		0.7	.10 (.07)		1475	1315	1070
06	2.6	.16 (.12)		1.2	.16 (.12)		1.0	.16 (.12)		1400	1070	855
08	3.4	.24 (.18)		1.4	.24 (.18)		1.1	.24 (.18)		1475	1285	975
10	1.6	2.6	.10 (.07) .16 (.12)	0.8	1.2	.10 (.07) .16 (.12)	0.7	1.0	.10 (.07) .16 (.12)	1475	1315	1070
										1400	1070	855
12	1.6	3.4	.10 (.07) .24 (.18)	0.5	0.9	.10 (.07) .24 (.18)	0.7	1.1	.10 (.12) .24 (.18)	1475	1315	1240
										1475	1285	975

Note:  
Actual rpm will vary with application and configuration

**Table ED-5. Free Discharge Motors on Units with Three and Four-Row Coils**

FC	115 Volt			208-230 Volt			277 Volt			RPM		
	FLA	HP (kW)		FLA	HP (kW)		FLA	HP (kW)		H	M	L
02	0.6	.03 (.02)		0.3	.03 (.02)		0.2	.03 (.02)		980	840	655
03	0.8	.05 (.04)		0.5	.05 (.04)		0.4	.05 (.04)		1080	800	600
04	1.0	.06 (.04)		0.6	.06 (.04)		0.5	.06 (.04)		1080	800	600
06	1.4	.12 (.09)		0.9	.12 (.09)		0.6	.12 (.09)		1080	800	600
08	1.7	.13 (.10)		1.0	.13 (.10)		0.8	.13 (.10)		1080	800	600
10	1.0	1.4	.06 (.04) .12 (.09)	0.6	0.9	.06 (.04) .12 (.09)	0.5	0.6	.06 (.04) .12 (.09)	1080	800	600
										1080	800	600
12	1.0	1.7	.06 (.04) .13 (.10)	0.6	1.0	.06 (.04) .13 (.10)	0.5	0.8	.06 (.04) .13 (.10)	1080	800	600
										1080	800	600

**Table ED-6. High Static Motors on Units with Three and Four-Row Coils**

FC	115 Volt			208-230 Volt			277 Volt			RPM		
	FLA	HP (kW)		FLA	HP (kW)		FLA	HP (kW)		H	M	L
02	1.1	.07 (.05)		0.6	.07 (.05)		0.5	.07 (.05)		1480	1110	865
03	1.3	.08 (.06)		0.7	.08 (.06)		0.5	.08 (.06)		1500	1355	1110
04	2.1	.13 (.10)		0.9	.13 (.10)		0.7	.13 (.10)		1580	1375	1240
06	3.4	.24 (.18)		1.4	.24 (.18)		1.1	.24 (.18)		1475	1285	975
08	3.4	.24 (.18)		1.4	.24 (.18)		1.1	.24 (.18)		1475	1285	975
10	2.1	3.4	.13 (.10) .24 (.18)	0.9	1.4	.13 (.10) .24 (.18)	0.7	1.1	.13 (.10) .24 (.18)	1580	1375	1240
										1475	1285	975
12	2.1	3.4	.13 (.10) .24 (.18)	0.9	1.4	.13 (.10) .24 (.18)	0.7	1.1	.13 (.10) .24 (.18)	1580	1375	1240
										1475	1285	975

Note:  
Actual rpm will vary with application and configuration.

# Electrical Data

**Table ED-7. Low Vertical Free Discharge Motors (115 Volt)**

FC	FLA	HP (kW)		RPM
03	0.7	.03 (0)	H	1090
			M	770
			L	560
04	0.8	.03 (0)	H	1090
			M	750
			L	560
06	1.1	.03 (0)	H	1115
			M	760
			L	560

Note:  
Actual rpm will vary with application and configuration.

**Table ED-8. Decimal to Fractional HP (kW) Conversion**

FC	Decimal		Fraction	
02	.03		1/30	
	.07		1/15	
03	.04		1/25	
	.05		1/20	
	.08		1/12	
04	.05		1/20	
	.06		1/16	
	.10		1/10	
	.13		1/8	
06	.07		1/15	
	.12		1/8	
	.16		1/6	
	.24		1/4	
08	.12		1/8	
	.13		1/8	
	.24		1/4	
10	.05	.07	1/20	1/15
	.06	.12	1/16	1/8
	.10	.16	1/10	1/6
	.13	.24	1/8	1/4
12	.05	.12	1/20	1/8
	.06	.13	1/16	1/8
	.10	.24	1/10	1/4
	.13	.24	1/8	1/4
Low Vertical 03, 04, 06	.03		1/30	

Note:  
Values for fractional HP's (kW's) are approximate values and not necessarily the actual HP (kW).

**Minimum Circuit Ampacity (MCA) and Maximum Fuse Size (MFS) Calculations for Fan-Coils: (Motors only, No Electric Heat)**

$$\text{MCA} = (1.25) \times [\text{Largest Motor Amperes (FLA)}] + \text{Second Motor Amperes (FLA)}$$

(Size 10 and 12 only)

MFS or HACR\* Type Circuit Breaker = 15 Amps for all Fan-Coils without Electric Heat

(See previous Electrical Data for units with Electric Heat.)

\*HACR (Heating, Air-Conditioning and Refrigeration) type circuit breakers are required in the branch circuit wiring for all size 10 and 12 fan-coils.



# Dimensions and Weights

## Unit Weights

**Table DW-1. Operating Weights — lbs. (kg)**

Unit Size	Cabinet Models	Concealed Models	Recessed Models	Low Vertical Cabinet Models	Low Vertical Concealed Models
02	97 (44)	81 (37)	78 (35)	NA	NA
03	97 (44)	81 (37)	78 (35)	125 (57)	109 (49)
04	125 (57)	109 (49)	88 (40)	155 (70)	139 (63)
06	155 (70)	139 (63)	128 (58)	164 (74)	147 (67)
08	164 (74)	147 (67)	139 (63)	NA	NA
10	218 (99)	200 (91)	253 (115)	NA	NA
12	218 (99)	200 (91)	253 (115)	NA	NA

**Table DW-2. Shipping Weights — lbs. (kg)**

Unit Size	Cabinet Models	Concealed Models	Recessed Models	Low Vertical Cabinet Models	Low Vertical Concealed Models
02	84 (38)	68 (31)	68 (31)	NA	NA
03	84 (38)	68 (31)	68 (31)	112 (51)	96 (44)
04	112 (51)	96 (44)	78 (35)	139 (63)	123 (56)
06	139 (63)	123 (56)	118 (54)	148 (67)	131 (59)
08	148 (67)	131 (59)	129 (59)	NA	NA
10	200 (91)	182 (83)	243 (110)	NA	NA
12	200 (91)	182 (83)	243 (110)	NA	NA

# Dimensions and Weights

# Vertical Concealed

## Vertical Concealed, Model A

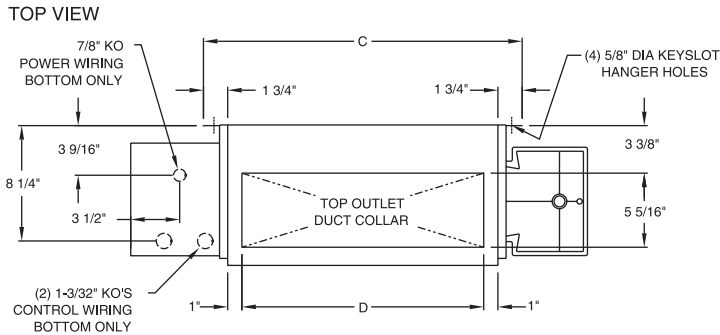

### Vertical Concealed Unit Dimensions

Unit Size	02-03	04	06	08	10-12
A	2'-8 11/16"	3'-1 11/16"	3'-11 3/16"	4'-7 11/16"	6'-2 11/16"
B	1'-9 5/16"	2'-2 5/16"	2'-11 13/16"	3'-8 5/16"	5'-3 5/16"
C	1'-10 13/16"	2'-3 13/16"	3'-1 5/16"	3'-9 13/16"	5'-4 13/16"
D	1'-5 5/16"	1'-10 5/16"	2'-7 13/16"	3'-4 5/16"	4'-11 5/16"
E	1'-7 5/16"	2'-0 5/16"	2'-9 13/16"	3'-6 5/16"	5'-1 5/16"

- NOTE: 1. Coil connections are always on the drain pan side and opposite the control box.  
 2. Coil connections are 5/8" O.D. sweat. See page 53 for locations.  
 3. All duct collar dimensions are to the outside of the collar.  
 4. See page 54 for fresh air opening dimensions.

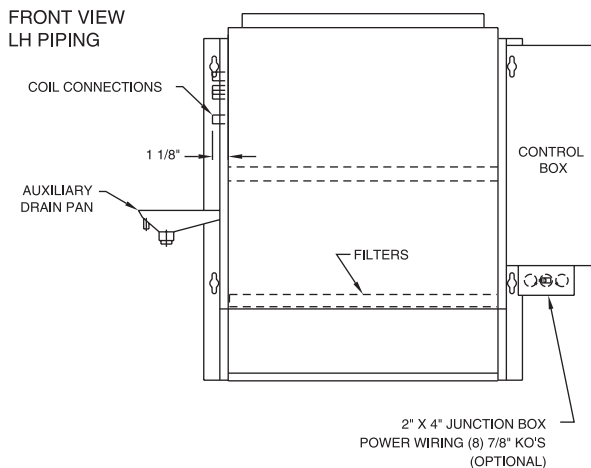
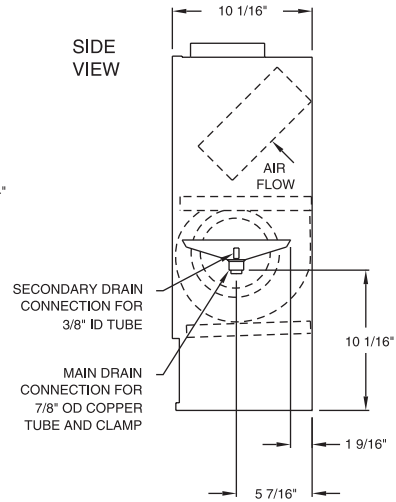
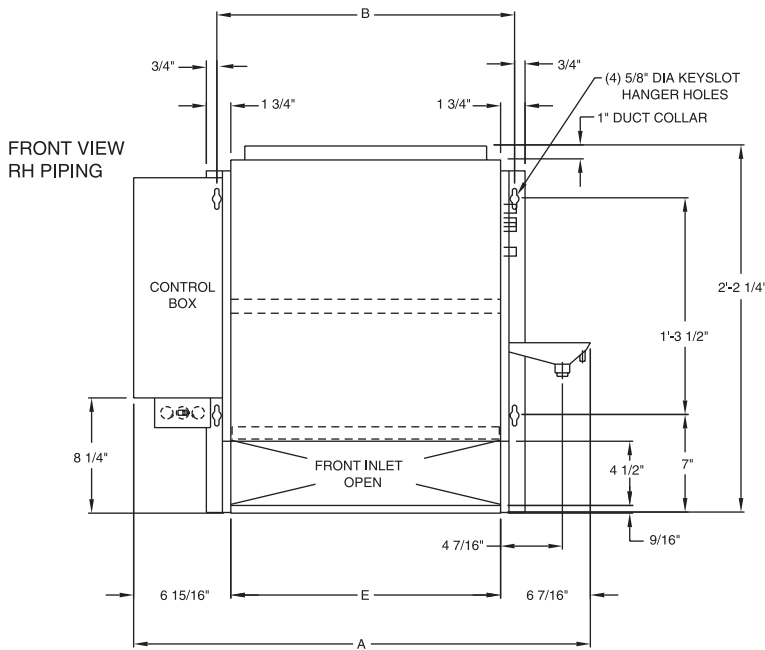

# Dimensions and Weights

# Vertical Cabinet

## Vertical Cabinet, Model B

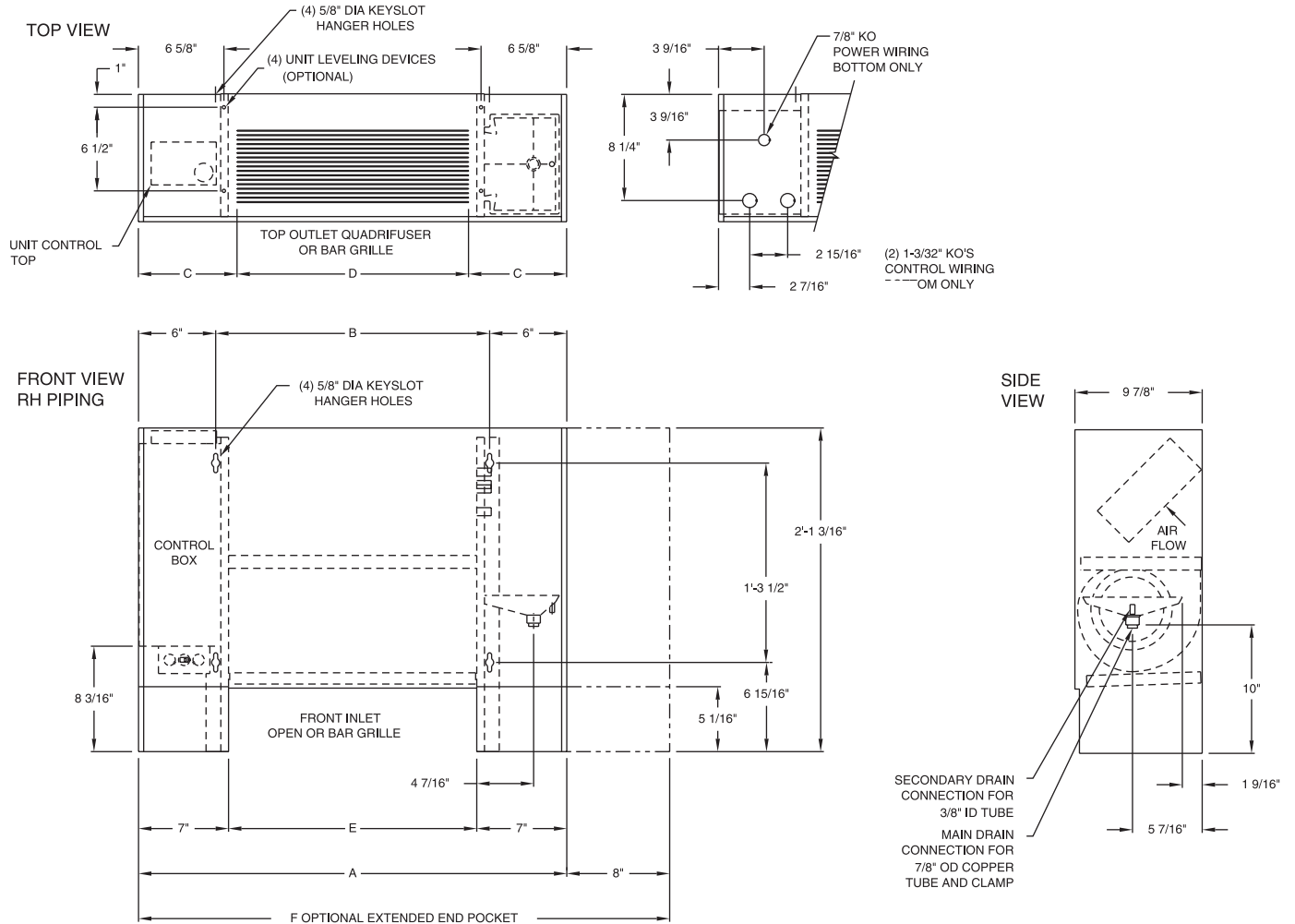

### Vertical Cabinet Unit Dimensions

Unit Size	02-03	04	06	08	10-12
A	2'-9 5/16"	3'-2 5/16"	3'-11 3/16"	4'-8 5/16"	6'-3 5/16"
B	1'-9 5/16"	2'-2 5/16"	2'-11 3/16"	3'-8 5/16"	5'-3 5/16"
C	7 5/8"	7 1/8"	8 7/8"	7 1/8"	7 5/8"
D	1'-6"	2'-0"	2'-6"	3'-6"	5'-0"
E	1'-7 5/16"	2'-0 5/16"	2'-9 13/16"	3'-6 5/16"	5'-1 5/16"
F	3'-5 5/16"	3'-10 5/16"	4'-7 3/16"	5'-4 5/16"	6'-11 5/16"

- NOTE: 1. Coil connections are always on the drain pan side and opposite the control box.  
 2. Coil connections are 5/8" O.D. sweat. See page 52 for locations.  
 3. All duct collar dimensions are to the outside of the collar.  
 4. See page 54 for fresh air opening dimensions.

# Dimensions and Weights

# Horizontal Concealed

## Horizontal Concealed, Model C

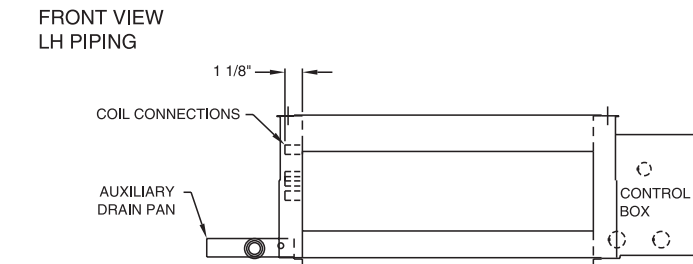
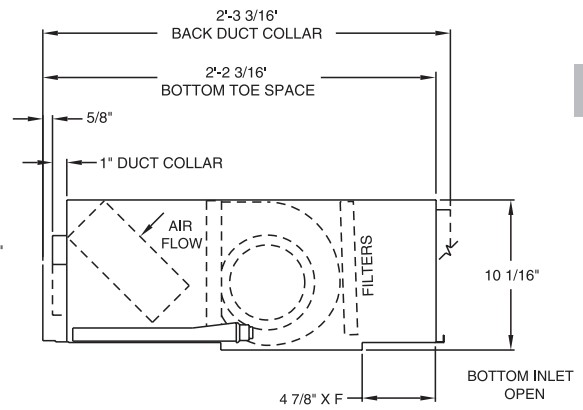
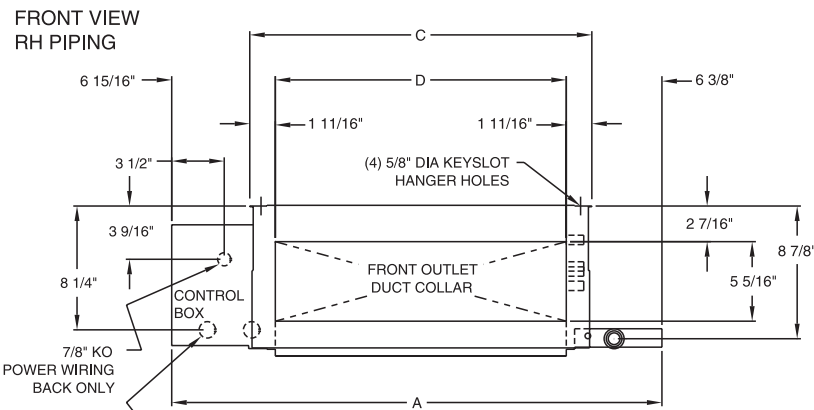
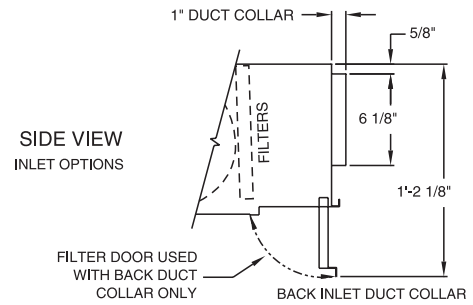
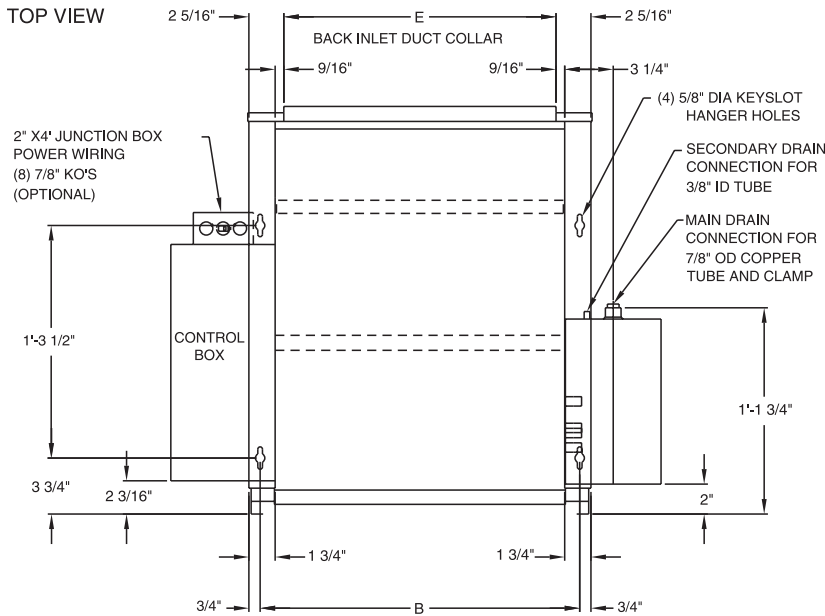

### Horizontal Concealed Unit Dimensions

Unit Size	02-03	04	06	08	10-12
A	2'-8 11/16"	3'-1 11/16"	3'-11 3/16"	4'-7 11/16"	6'-2 11/16"
B	1'-9 5/16"	2'-2 5/16"	2'-11 13/16"	3'-8 5/16"	5'-3 5/16"
C	1'-10 13/16"	2'-3 13/16"	3'-1 5/16"	3'-9 13/16"	5'-4 13/16"
D	1'-7 3/8"	2'-0 3/8"	2'-9 7/8"	3'-6 3/8"	5'-1 3/8"
E	1'-6 1/8"	1'-11 1/8"	2'-8 5/8"	3'-5 1/8"	5'-0 1/8"
F	1'-7 5/16"	2'-0 5/16"	2'-9 13/16"	3'-6 5/16"	5'-1 5/16"

NOTE: 1. Coil connections are always on the drain pan side and opposite the control box.  
 2. Coil connections are 5/8" O.D. sweat. See page 52 for locations.  
 3. All duct collar dimensions are to the outside of the collar.  
 4. See page 53 for fresh air opening dimensions.

# Dimensions and Weights

# Horizontal Cabinet

## Horizontal Cabinet, Model D

TOP VIEW

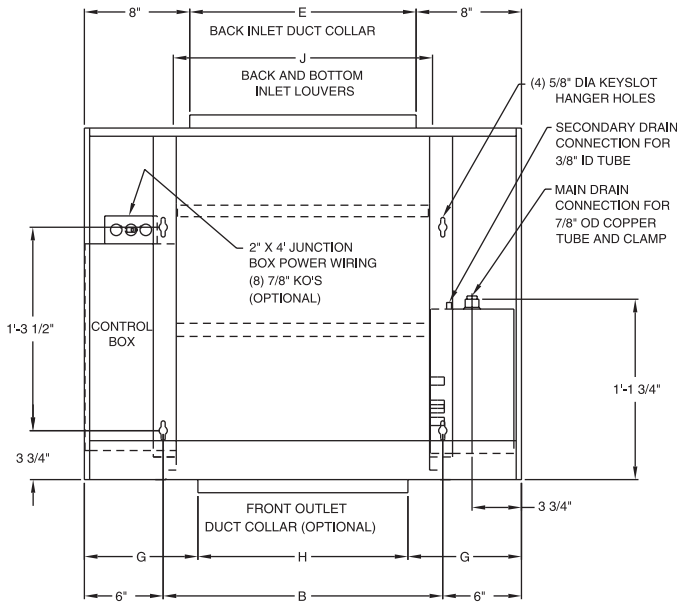

FRONT VIEW  
RH PIPING

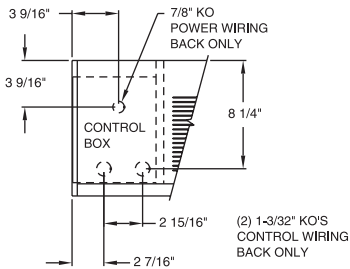
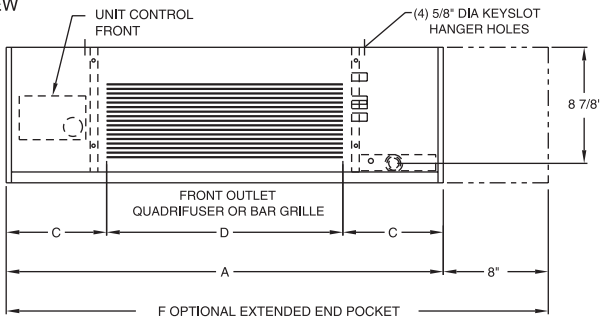

FRONT VIEW  
LH PIPING

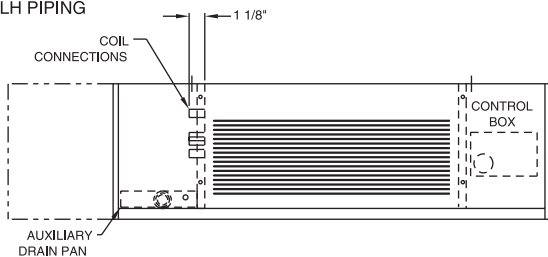

### Horizontal Cabinet Unit Dimensions

Unit Size	02-03	04	06	08	10-12
A	2'-9 5/16"	3'-2 5/16"	3'-11 3/16"	4'-8 5/16"	6'-3 5/16"
B	1'-9 5/16"	2'-2 5/16"	2'-11 13/16"	3'-8 5/16"	5'-3 5/16"
C	7 5/8"	7 1/8"	8 7/8"	7 1/8"	7 5/8"
D	1'-6"	2'-0"	2'-6"	3'-6"	5'-0"
E	1'-5 1/4"	1'-10 1/4"	2'-7 3/4"	3'-4 1/4"	4'-11 1/4"
F	3'-5 5/16"	3'-10 5/16"	4'-7 3/16"	5'-4 5/16"	6'-11 5/16"
G	8 5/8"	8 1/8"	9 7/8"	8 1/8"	8 5/8"
H	1'-4"	1'-10"	2'-4"	3'-4"	4'-10"
J	1'-7 3/4"	1'-11 3/4"	2'-7 3/4"	3'-3 3/4"	4'-11 3/4"

- NOTE: 1. Coil connections are always on the drain pan side and opposite the control box.  
 2. Coil connections are 5/8" O.D. sweat. See page 52 for locations.  
 3. All duct collar dimensions are to the outside of the collar.  
 4. See page 53 for fresh air opening dimensions.

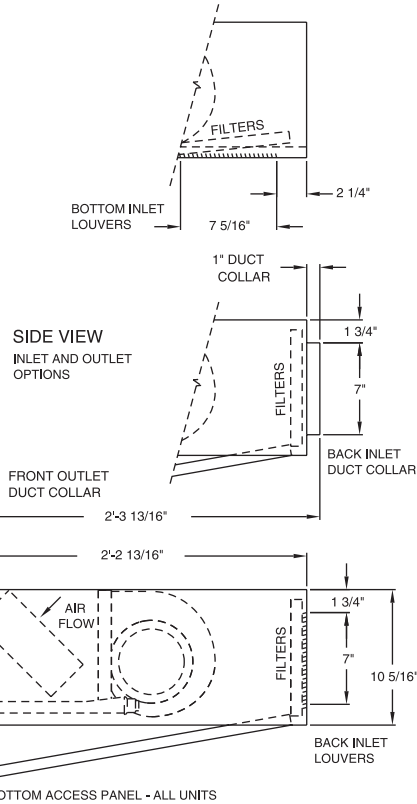

# Dimensions and Weights

# Horizontal Recessed

## Horizontal Recessed, Model E

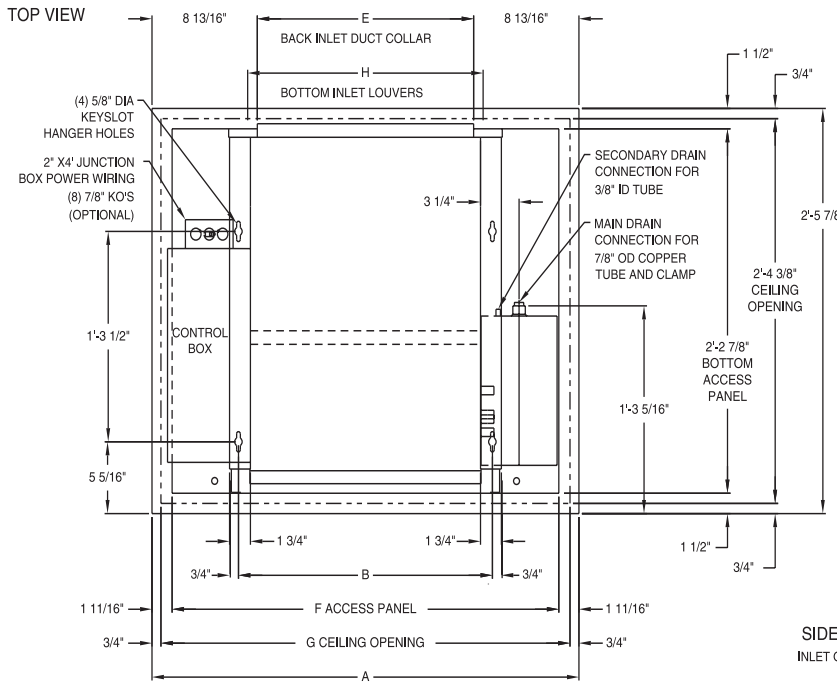

**Horizontal Recessed Unit Dimensions**

Unit Size	02-03	04	06	08	10-12
A	2'-11 13/16"	3'-4 13/16"	4'-2 5/16"	4'-10 13/16"	6'-5 13/16"
B	1'-9 5/16"	2'-2 5/16"	2'-11 13/16"	3'-8 5/16"	5'-3 5/16"
C	1'-10 13/16"	2'-3 13/16"	3'-1 5/16"	3'-9 13/16"	5'-4 13/16"
D	1'-7 3/8"	2'-0 3/8"	2'-9 7/8"	3'-6 3/8"	5'-1 3/8"
E	1'-6 1/8"	1'-11 1/8"	2'-8 5/8"	3'-5 1/8"	5'-0 1/8"
F	2'-8 7/16"	3'-1 7/16"	3'-10 15/16"	4'-7 7/16"	6'-2 7/16"
G	2'-10 5/16"	3'-3 5/16"	4'-0 13/16"	4'-9 5/16"	6'-4 5/16"
H	1'-7 3/4"	1'-11 3/4"	2'-7 3/4"	3'-3 3/4"	4'-11 3/4"

- NOTE: 1. Coil connections are always on the drain pan side and opposite the control box.  
 2. Coil connections are 5/8" O.D. sweat. See page 52 for locations.  
 3. All duct collar dimensions are to the outside of the collar.  
 4. See page 53 for fresh air opening dimensions.

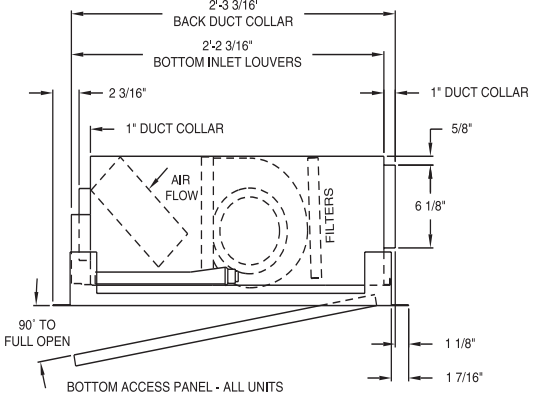
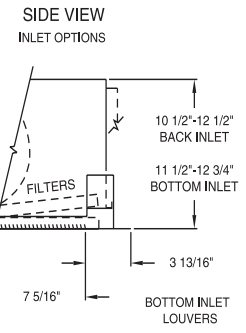
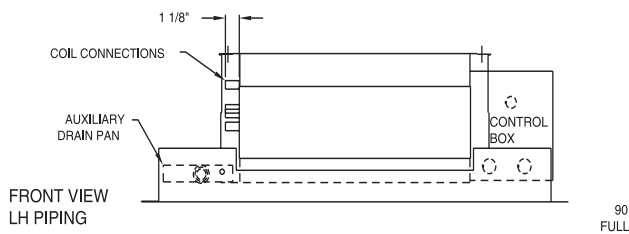
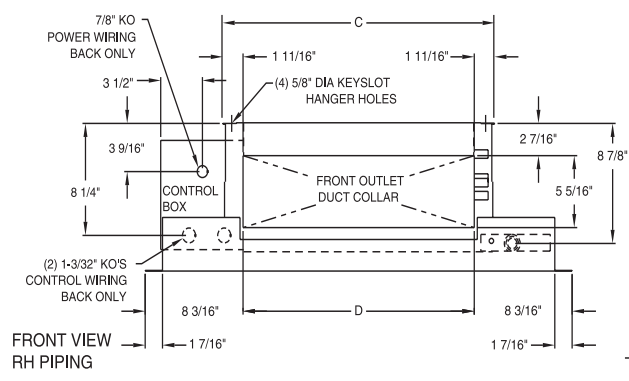

# Dimensions and Weights

# Vertical Recessed

## Vertical Recessed, Model H

TOP VIEW

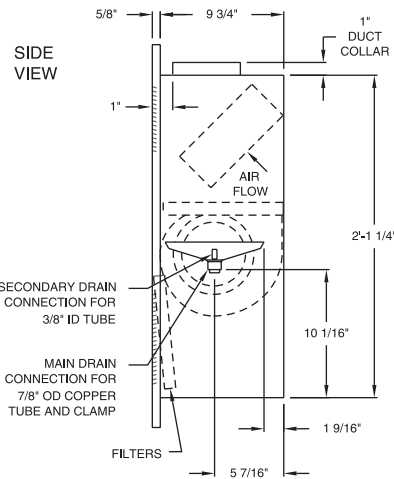
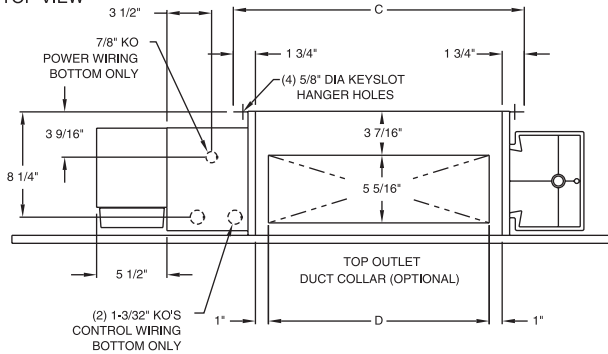

FRONT VIEW RH PIPING

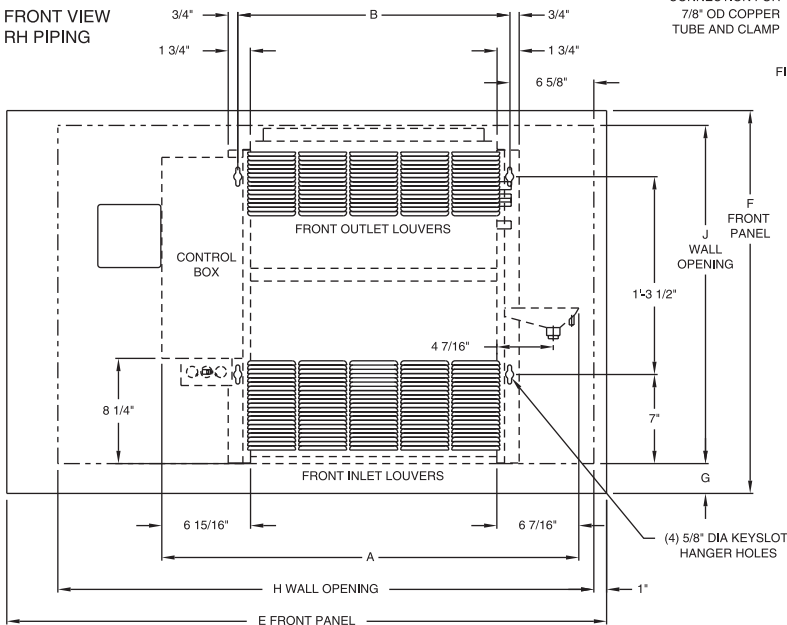

### Vertical Recessed Unit Dimensions

Unit Size	02-03	04	06	08	10-12
A	2'-8 11/16"	3'-1 11/16"	3'-11 3/16"	4'-7 11/16"	6'-2 11/16"
B	1'-9 5/16"	2'-2 5/16"	2'-11 13/16"	3'-8 5/16"	5'-3 5/16"
C	1'-10 13/16"	2'-3 13/16"	3'-1 5/16"	3'-9 13/16"	5'-4 13/16"
D	1'-5 5/16"	1'-10 5/16"	2'-7 13/16"	3'-4 5/16"	4'-11 5/16"
E	3'-11"	4'-3"	5'-3"	5'-5 1/2"	7'-5 1/2"
F	2'-6"	2'-6"	2'-6"	2'-9 1/2"	2'-9 1/2"
G	2 3/8"	2 3/8"	2 3/8"	4 1/8"	4 1/8"
H	3'-6"	4'-0"	4'-9"	5'-3"	7'-3"
J	2'-2 1/2"	2'-2 1/2"	2'-2 1/2"	2'-3 1/2"	2'-3 1/2"

- NOTE: 1. Coil connections are always on the drain pan side and opposite the control box.  
 2. Coil connections are 5/8" O.D. sweat. See page 52 for locations.  
 3. All duct collar dimensions are to the outside of the collar.  
 4. See page 54 for fresh air opening dimensions.

FRONT VIEW LH PIPING

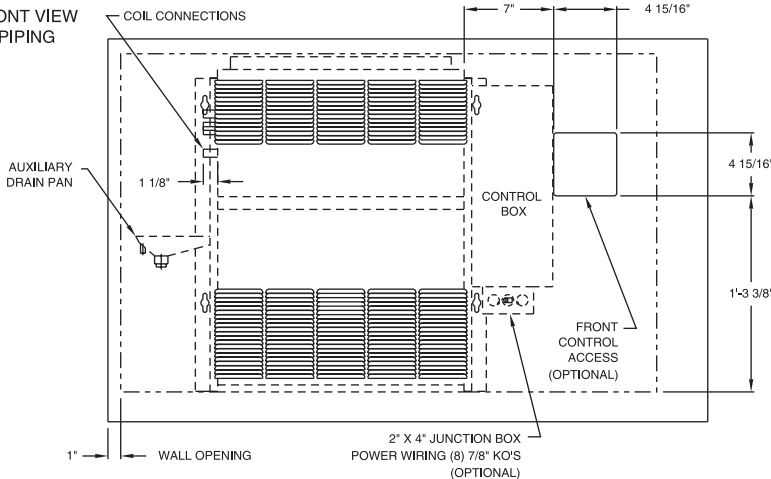

# Dimensions and Weights

# Vertical Slope Top

## Vertical Slope Top, Model J

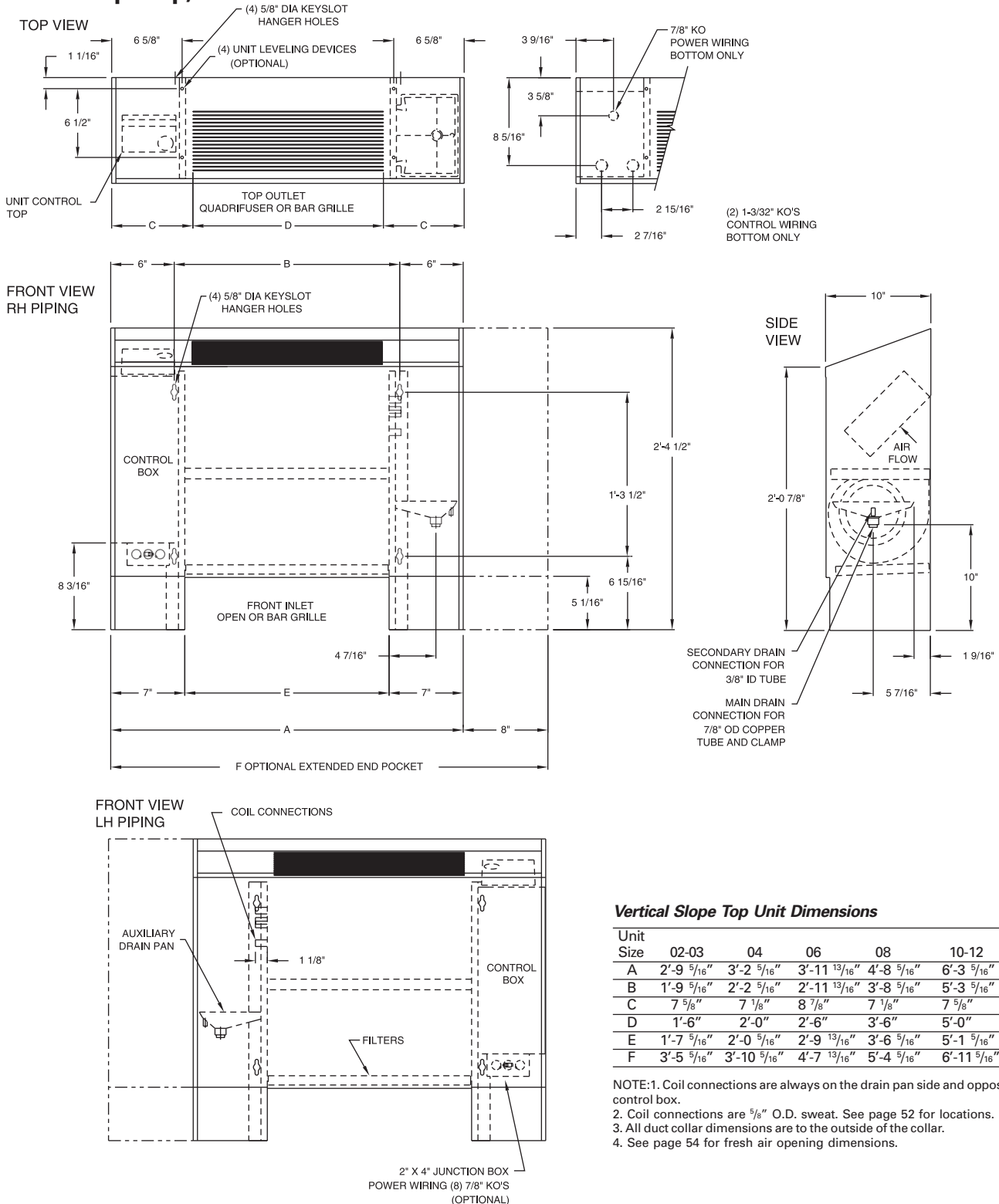

### Vertical Slope Top Unit Dimensions

Unit Size	02-03	04	06	08	10-12
A	2'-9 5/16"	3'-2 5/16"	3'-11 13/16"	4'-8 5/16"	6'-3 5/16"
B	1'-9 5/16"	2'-2 5/16"	2'-11 13/16"	3'-8 5/16"	5'-3 5/16"
C	7 5/8"	7 1/8"	8 7/8"	7 1/8"	7 5/8"
D	1'-6"	2'-0"	2'-6"	3'-6"	5'-0"
E	1'-7 5/16"	2'-0 5/16"	2'-9 13/16"	3'-6 5/16"	5'-1 5/16"
F	3'-5 5/16"	3'-10 5/16"	4'-7 13/16"	5'-4 5/16"	6'-11 5/16"

- NOTE: 1. Coil connections are always on the drain pan side and opposite the control box.  
 2. Coil connections are 5/8" O.D. sweat. See page 52 for locations.  
 3. All duct collar dimensions are to the outside of the collar.  
 4. See page 54 for fresh air opening dimensions.

# Dimensions and Weights

# Low Vertical Concealed

## Low Vertical Concealed, Model K

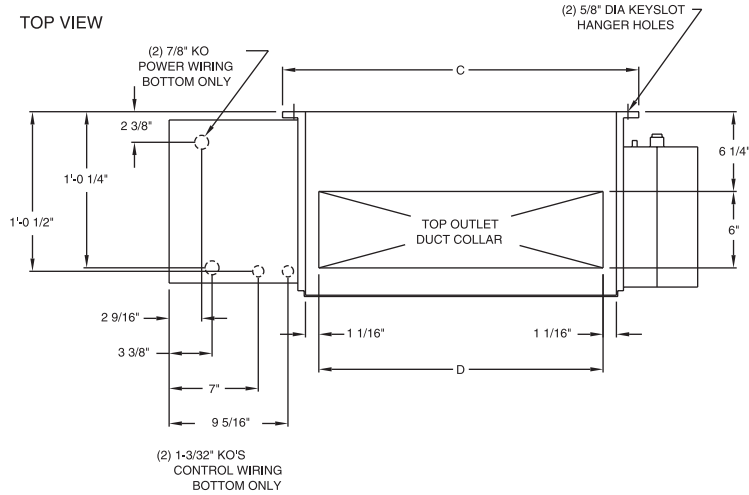

**Low Vertical Concealed Unit Dimensions**

Unit Size	03	04	06
A	3'-5 7/16"	4'-2 15/16"	4'-11 7/16"
B	2'-2 1/4"	2'-11 3/4"	3'-8 1/4"
C	2'-3 15/16"	3'-0 13/16"	3'-9 15/16"
D	1'-10 5/16"	2'-7 13/16"	3'-4 5/16"
E	2'-0 1/4"	2'-9 3/4"	3'-6 1/4"

- NOTE: 1. Coil connections are always on the drain pan side and opposite the control box.  
 2. Coil connections are 5/8" O.D. sweat.  
 3. All duct collar dimensions are to the outside of the collar.  
 4. See page 55 for fresh air opening dimensions.

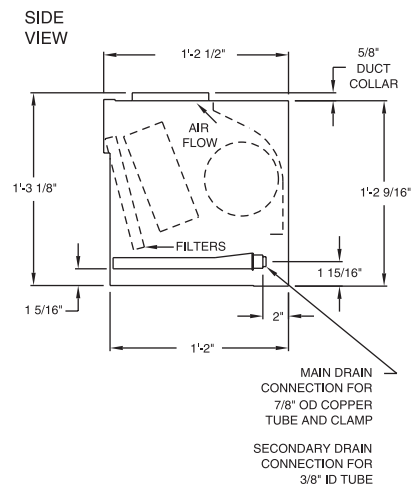
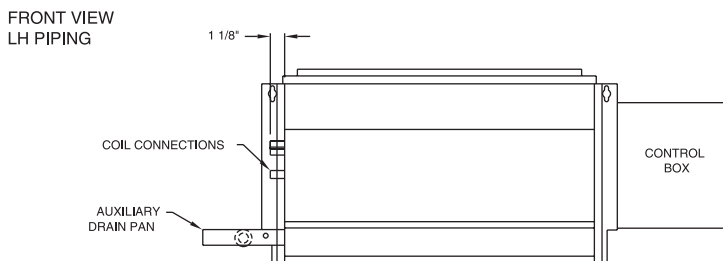
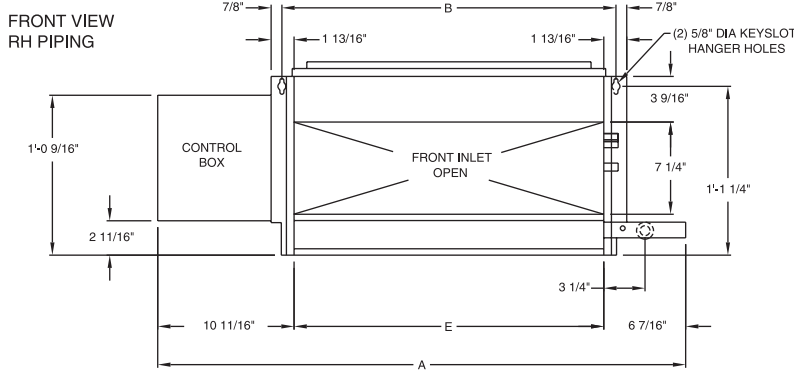

# Dimensions and Weights

# Low Vertical Cabinet

## Low Vertical Cabinet, Model L

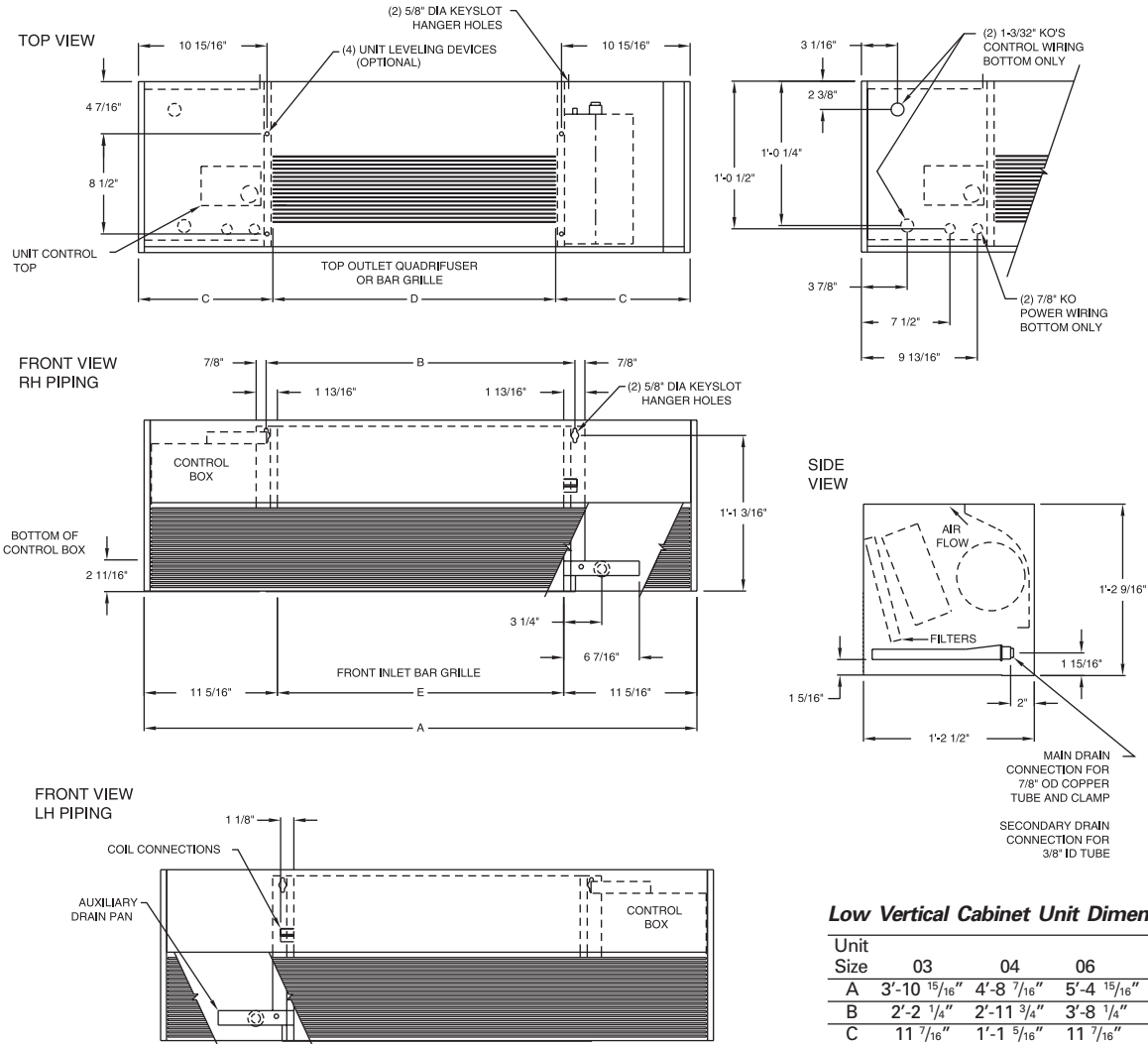

### Low Vertical Cabinet Unit Dimensions

Unit Size	03	04	06
A	3'-10 15/16"	4'-8 7/16"	5'-4 15/16"
B	2'-2 1/4"	2'-11 3/4"	3'-8 1/4"
C	11 7/16"	1'-1 5/16"	11 7/16"
D	2'-0"	2'-6"	3'-6"
E	2'-0 1/4"	2'-9 3/4"	3'-6 1/4"

- NOTE: 1. Coil connections are always on the drain pan side and opposite the control box.  
 2. Coil connections are 5/8" O.D. sweat.  
 3. All duct collar dimensions are to the outside of the collar.  
 4. See page 55 for fresh air opening dimensions.

# Dimensions and Weights

# Coil Connections

## Coil Connections, Vertical Units

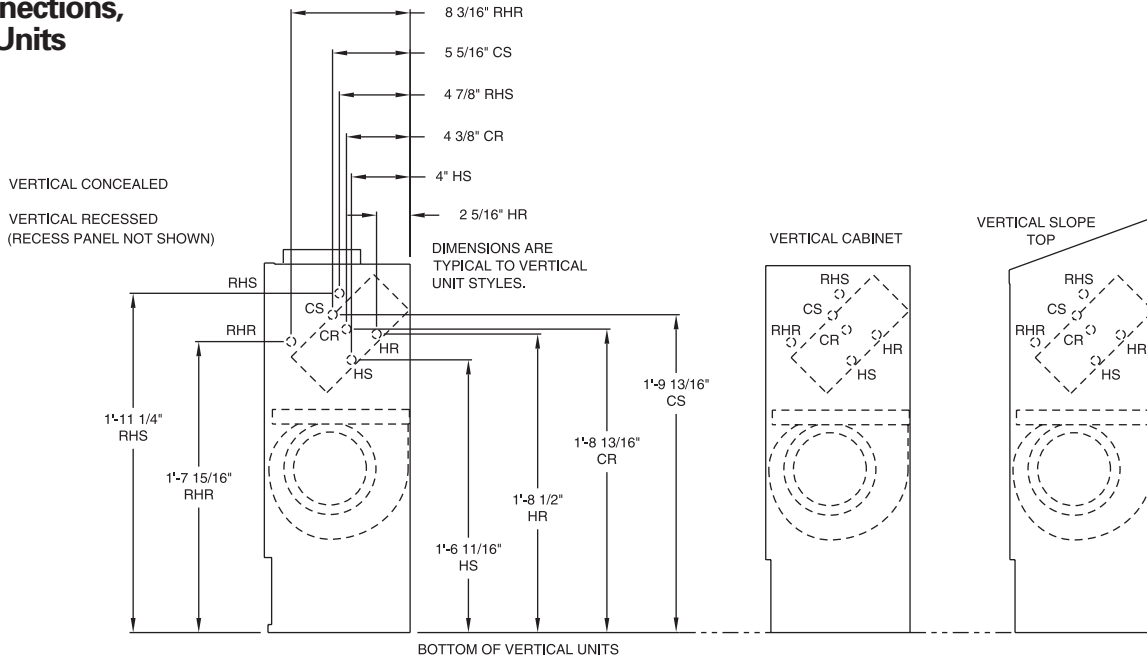

## Coil Connections, Horizontal Units

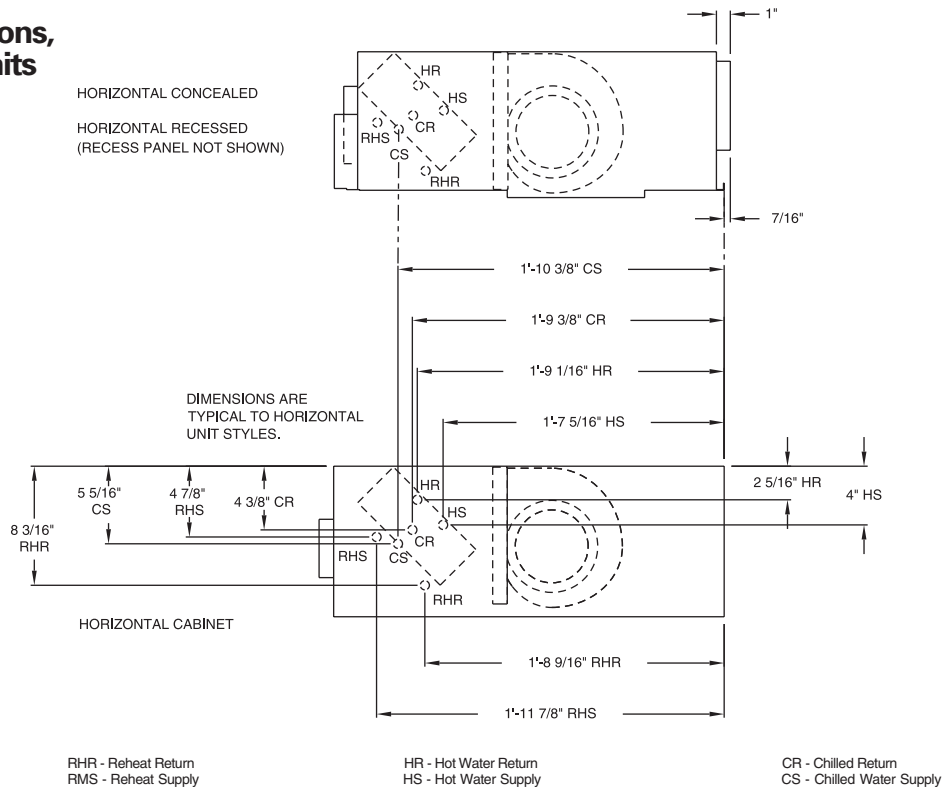

Note: Reheat coils are available with 2-pipe main coils only on units with either a fan speed switch or Tracer ZN520 control.

# Dimensions and Weights

# Fresh Air Opening

## Fresh Air Opening Locations Horizontal Units Models C, D, and E

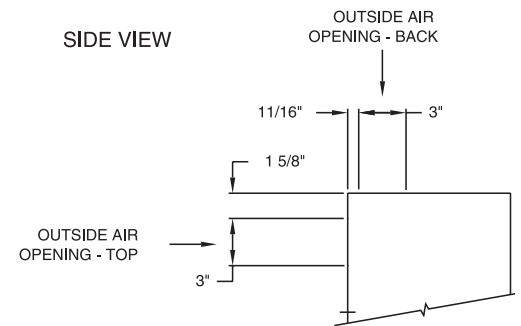
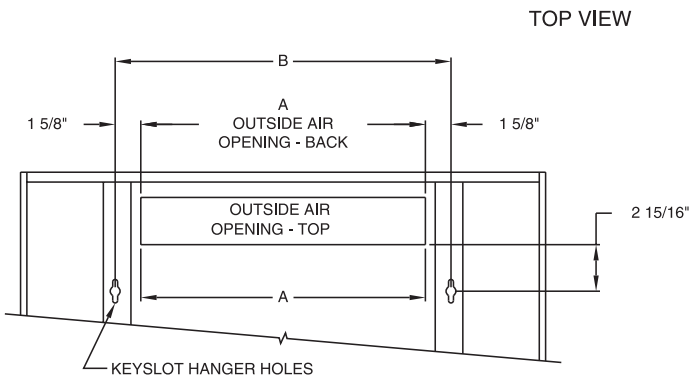
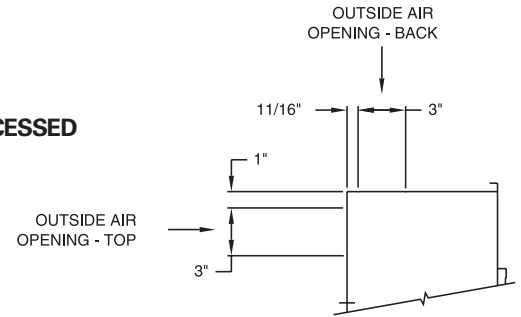
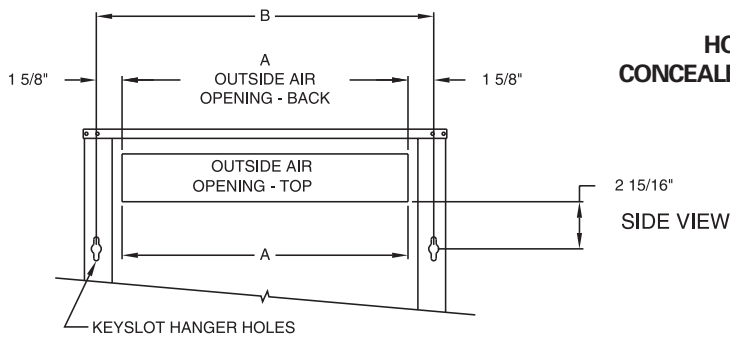

**Fresh Air Opening Dimensions, Horizontal Units**

Unit Size	02-03	04	06	08	10-12
A	1'-6"	1'-11"	2'-8 1/2"	3'-5"	5'-0"
B	1'-9 5/16"	2'-2 5/16"	2'-11 13/16"	3'-8 5/16"	5'-3 5/16"



# Dimensions and Weights

# Fresh Air Opening

## Fresh Air Opening Locations Vertical Units Models A, B, and J

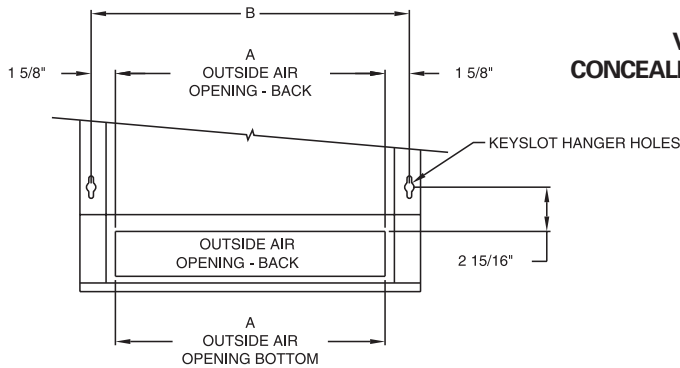

**VERTICAL  
CONCEALED AND RECESSED**

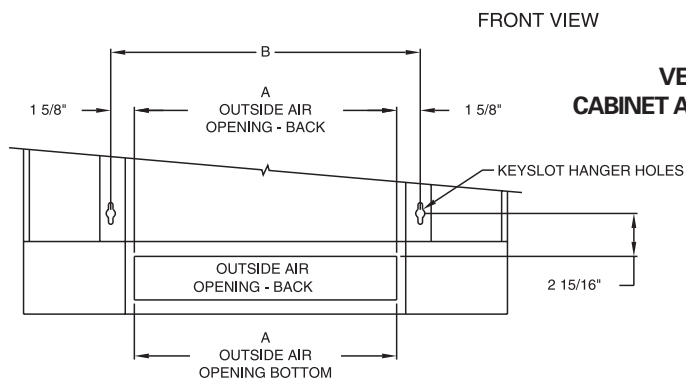
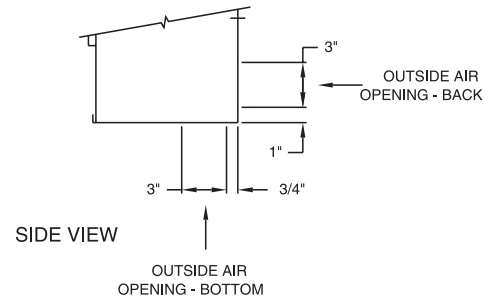

**VERTICAL  
CABINET AND SLOPE TOP**

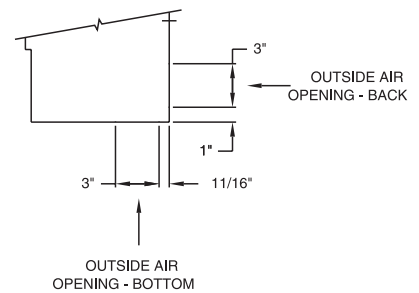

**Fresh Air Opening Dimensions, Vertical Units**

Unit Size	02-03	04	06	08	10-12
A	1'-6"	1'-11"	2'-8 1/2"	3'-5"	5'-0"
B	1'-9 5/16"	2'-2 5/16"	2'-11 13/16"	3'-8 5/16"	5'-3 5/16"

# Dimensions and Weights

# Fresh Air Opening

## Fresh Air Opening Locations Low Vertical Units Models K and L

*Fresh Air Opening Dimensions, Low Vertical Units*

Unit Size	03	04	06
A	2'-0 1/4"	2'-9 3/4"	3'-6 1/4"
B	2'-2 1/4"	2'-11 3/4"	3'-8 1/4"

**LOW VERTICAL CABINET  
REAR VIEW**

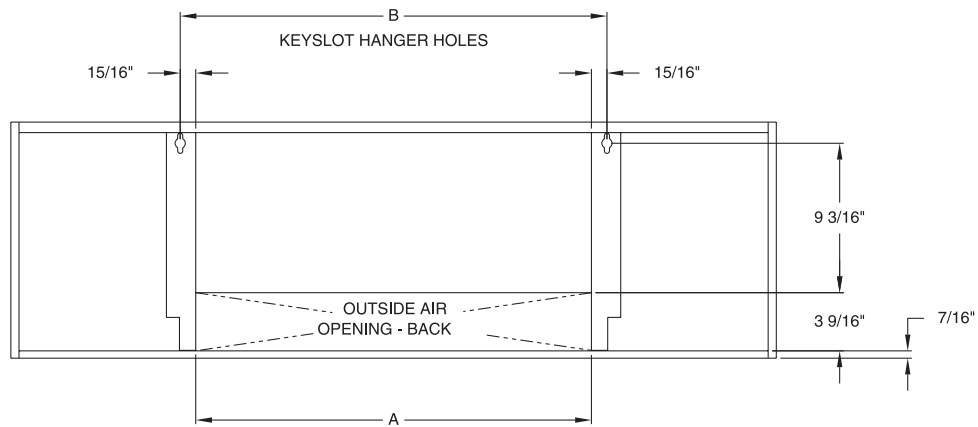

**LOW VERTICAL CONCEALED  
REAR VIEW**

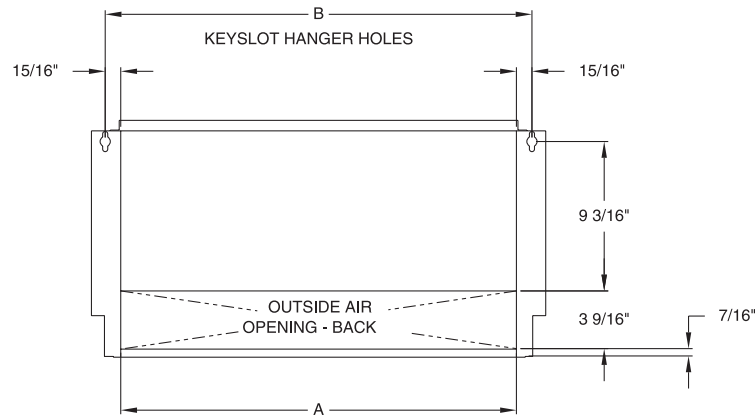

# Dimensions and Weights

## Wall Box

### Wall Box

#### Wall Box Dimensions

Unit Size Ref. Only	Dimensions A x B	Internal Supports
02 - 03	24 <sup>3</sup> / <sub>8</sub> x 4 <sup>3</sup> / <sub>4</sub>	1
04	24 <sup>3</sup> / <sub>8</sub> x 7 <sup>1</sup> / <sub>2</sub>	1
06	33 <sup>1</sup> / <sub>8</sub> x 7 <sup>1</sup> / <sub>2</sub>	2
08	37 <sup>1</sup> / <sub>2</sub> x 7 <sup>1</sup> / <sub>2</sub>	3
10 - 12	58 <sup>1</sup> / <sub>4</sub> x 7 <sup>1</sup> / <sub>2</sub>	4

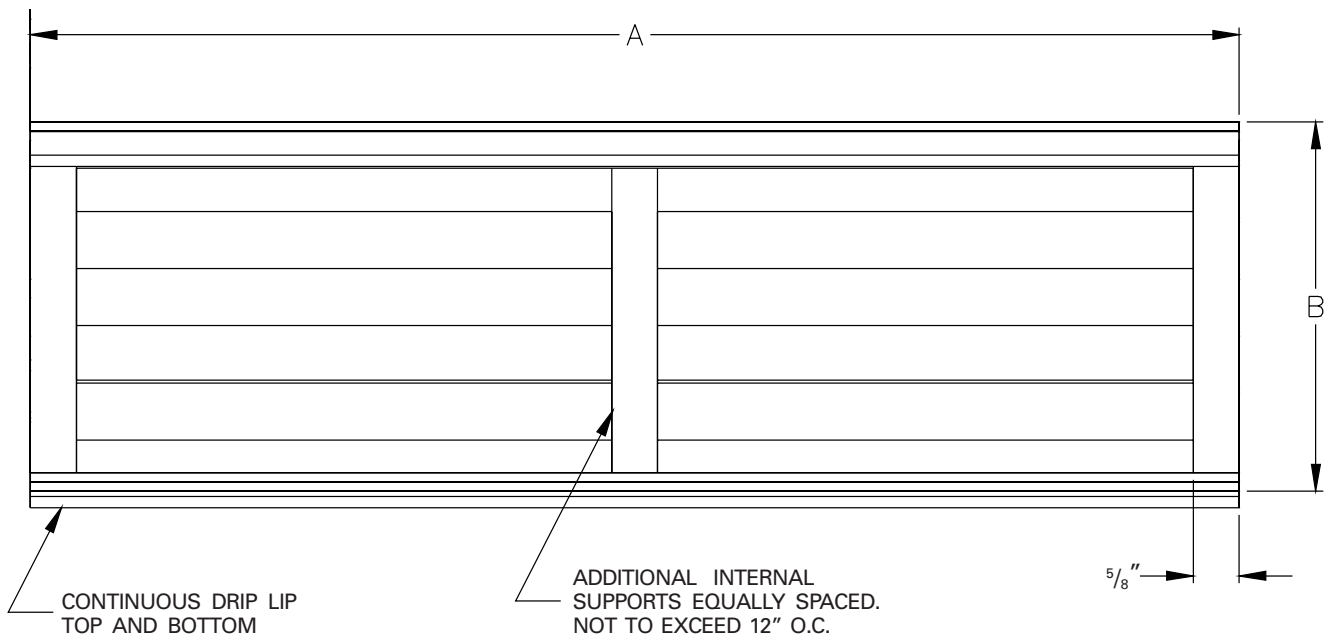
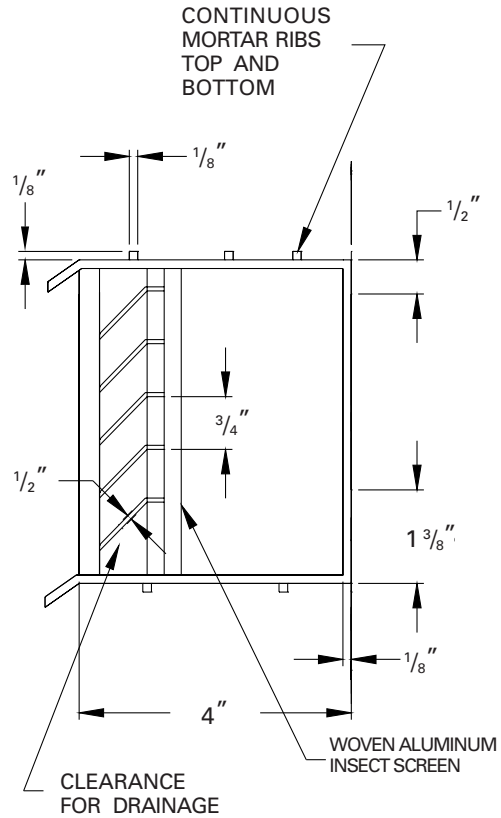

# Dimensions and Weights

# Projection Panel

## Projection Panel

### Projection Panel Dimensions

Unit Size	02 - 03	04	06	08	10 - 12
A	3'-11"	4'-3"	5'-3"	5'-5 1/2"	7'-5 1/2"
B	2'-6"	2'-6"	2'-6"	2'-9 1/2"	2'-9 1/2"

### Projection Panel, All Unit Sizes

C	2"	2 1/2"	3"	3 1/2"	4"	4 1/2"	5"	5 1/2"	6"
D	1 1/8"	1 5/8"	2 1/8"	2 5/8"	3 1/8"	3 5/8"	4 1/8"	4 5/8"	5 1/8"
E	8 5/8"	8 1/8"	7 5/8"	7 1/8"	6 5/8"	6 1/8"	5 5/8"	5 1/8"	4 5/8"

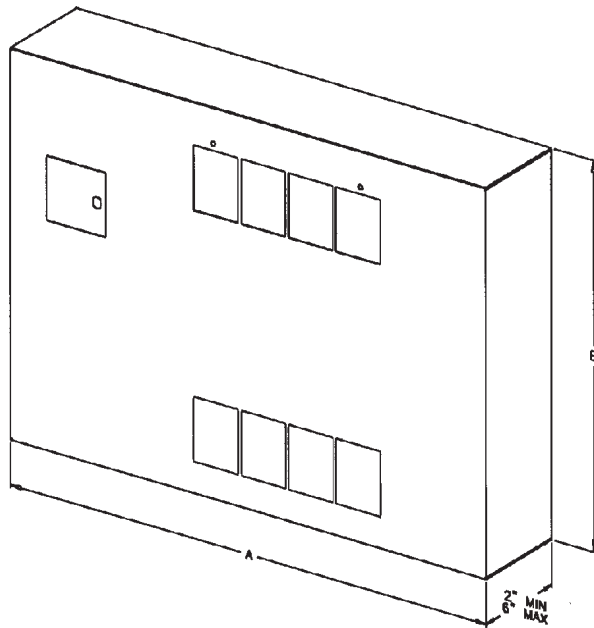

FRONT VIEW ISO

### UNIT TO WALL — TOP VIEW

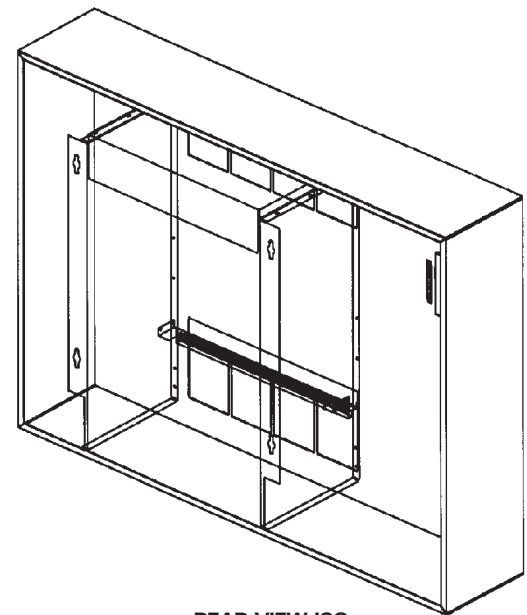
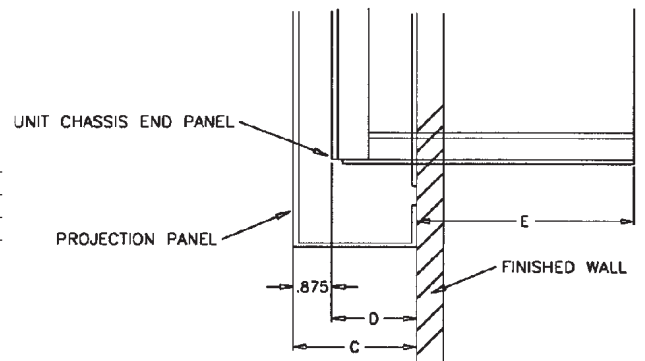

REAR VIEW ISO



# Mechanical Specifications

## UniTrane® Fan-Coil Mechanical Specifications

### Performance Data

Capacity: Unit capacities are certified under Industry Room Fan-Coil Air Conditioner Certification Program in accordance with ARI Standard 440-97. Safety: All standard units are UL listed in the United States and Canada and comply with NFPA 90A requirements.

### Construction

#### All Units

The unit includes a chassis, coil(s), fan wheel(s), fan casing(s), fan board and motor(s). Units also include a noncorrosive, ABS main drain pan, positively sloped in every plane and insulated with closed-cell insulation. Horizontal units and all units with standard piping packages also include a thermoplastic auxiliary drain pan. Steel parts exposed to moisture are galvanized. The fan board assembly and both drain pans are easily removable. The fan board assembly includes a quick-disconnect motor plug. The chassis construction is 18-gage galvanized steel, and continuous throughout the unit. The unit is acoustically and thermally insulated with closed-cell insulation. All panels are made rigid by channel forming.

#### Vertical Cabinet and Slope Top Units

Front panel fabrication is 16-gage galvanized steel. All other panels are 18-gage galvanized steel. The discharge grille is recessed to resist condensate formation. Hinged access door construction is 20-gage steel and is flush with top panel.

#### Horizontal Cabinet Units

All panels are 18-gage galvanized steel, including the bottom panel. Discharge grille is recessed to resist condensate formation. The hinged access door is flush with front panel. Bottom panels ship with tamperproof screw fasteners and a safety chain.

#### Concealed/Recessed Units

Exposed panels on recessed units are 18-gage steel construction and ship separate from the unit. Bottom panels on horizontal recessed models ship standard with tamperproof screw fasteners and a safety chain.

#### Low Vertical Unit

Front panels are of 16-gage galvanized steel. All cabinet parts are made rigid by channel forming. End panel is removable for piping access. Hinged access door construction is 20-gage steel and flush with top panel.

#### Unit Finish

All cabinet parts and exposed recessed panels are cleaned, bonderized, phosphatized, and painted with a baked powder finish available in six decorator colors. Standard finish meets ASTM B117 specifications (salt spray test).

#### Fans

The aluminum fan wheels are centrifugal forward-curved and double-width. Fan wheels and housings are corrosion resistant. Fan housing construction is formed sheet metal. Low vertical units utilize a tangential wheel design.

#### Motors

All permanent split capacitor motors are run tested in assembled units. All motors have integral thermal overload protection with a maximum ambient operating temperature of 104°F and are permanently lubricated. Motors are capable of starting at 78% of rated voltage and operating at 90% of rated voltage on all speed settings. Motors can operate up to 10% over voltage.

#### Coils

All water coils are burst tested at 450 psig (3,103 kPa) (air) and leak tested at 100 psig (690 kPa) (air under water). Maximum main coil working pressure is 300 psig (2,069 kPa). Maximum entering water temperature is 200°F (93°C). Tubes and u-bends are  $\frac{3}{8}$ " (10 mm) OD copper. Fins are aluminum and are mechanically bonded to the copper tubes. Coil stubouts are  $\frac{5}{8}$ " (16 mm) OD copper tubing.

#### Reheat Coils

Reheat coils are available for use with both hot water and steam. Hot water maximum working pressure is 300 psig (2,069 kPa), and the maximum entering water temperature is 200°F (93°C). The steam coil maximum working pressure is 15 psig (103 kPa). The reheat coils are constructed of single circuit  $\frac{5}{8}$ " (16 mm) copper tubes with aluminum fins. Piping connections are expanded to accept standard copper tubing  $\frac{5}{8}$ " (16 mm) OD.

#### Piping Packages

All piping packages are burst tested at 450 psig (3,103 kPa) (air) and leak tested at 100 psig (690 kPa) (air under water). The maximum working pressure of the interconnecting piping is 300 psig (2,069 kPa).

Piping packages are available in either basic or deluxe configurations. The deluxe package includes unions at the coil connections and a 20 mesh strainer on the supply side with a pressure rating on the strainer of up to 400 psig (2,758 kPa). The basic package does not include either unions or the strainer. A choice of end valves are available on both the basic and deluxe piping packages.

The piping package is designed so that any condensation is directed into the UniTrane® auxiliary drain pan. Insulation of piping package is not required.

#### Ball Valve Supply and Return

A ball-type stop valve is available on both the supply and return of the piping package. The ball valve is a shutoff valve only with a maximum working pressure of 400 psig (2,758 kPa).

#### Ball Valve Supply, Manual Circuit Setter Return

A ball valve is provided on the supply with a manual circuit setter on the return. The manual circuit setter is a combination flow-setting device and shutoff valve that includes two Schrader ports. The maximum working pressure of the valve is 300 psig (2,069 kPa).

#### Ball Valve S & R, Auto Circuit Setter Return

Ball type end valves are mounted on the supply and return, with an additional auto circuit setter mounted on the return. The auto circuit setter is an automatic flow control valve that is sized to allow a specific flowrate through the coil. Auto circuit setters also include two P/T plugs and have a maximum working pressure of 400 psig (2,758 kPa).

#### Two-Way, Two-Position Control Valves

Two-way, two-position valves are rated for a maximum pressure differential across the valves of 30 psig (207 kPa). The valves are also available with a close-off pressure of 50 psig (345 kPa). The valve actuator is easily removable for service without removing the valve

# Mechanical Specifications

body from piping. Use some means, such as a pump and chiller bypass, to ensure the maximum closed off  $\Delta P$  rating of the two-way valves is not exceeded.

### Three-Way, Two-Position Control Valves

Normally open three-way, two-position valves are rated for a maximum 28 psig (193 kPa) pressure differential across the valves. Normally closed three-way two-position valves are rated for a maximum pressure differential across the valves of 20 psig (138 kPa). A bypass line is piped on all three-way piping packages with a balance fitting to set flow through the bypass line. The balance fitting has a maximum working pressure of 150 psig (1,034 kPa). The valves are also available with a maximum close-off pressure of 50 psig (345 kPa). The valve actuator is easily removable for service without removing the valve body from piping.

### Modulating Control Valves

Two-way and three-way modulating valves are rated for a maximum pressure differential across the valves of 50 psig (345 kPa). The modulating valves are available in Cv values of 0.7, 1.5, 2.5 and 4.0.

All two-position and modulating control valves have a maximum working pressure of 300 psig (2,069 kPa). The maximum entering water temperature of the valve is 200°F (93°C).

### Electric Heat Coil

The auxiliary electric heating coil is provided as either the total source of heat or auxiliary intermediate season heating. The electric heat coils are located in the preheat position, and are the open-wire type. The coils are a nickel chromium element design. The electric heat operates at the same voltage as the unit, and only a single power connection is necessary.

All standard electric heat coils are UL listed and interlocked with the fan motor switch. Therefore, electric heat operation is possible only when the fan is running. A transformer is supplied on any voltage unit, eliminating the need for field

installation of a step-down transformer. A unit-mounted magnetic contactor is supplied on all voltages. A high temperature cutout with automatic reset is provided as an integral part of the elements to de-energize the electric heat in the event of an overheat condition.

### Filters

Filters are concealed from sight and easily removable. Filters are located behind an integral access door on horizontal type units. Filters are either 1" (25 mm) throwaway or 1" (25 mm) pleated media throwaway. Pleated media filters are Farr 30/30.

### Fresh Air Damper

A fresh air opening with a damper is a factory-installed option. Dampers are constructed of 18-gage steel. Fresh air is sealed off with gasket material when the damper is set in the closed position. Return and fresh air mixes when the damper is open.

#### • Manual Damper

The manual damper is field-adjustable to allow a zero to 100% fresh air position. The automatic two-position damper is accompanied by a factory-installed and wired two-position (spring-return) actuator.

#### • Auto Two-Position Damper

The auto two-position damper is factory set at 25% when open. The damper can be set in the field to allow a zero to 50% fresh air position.

#### • Economizer Damper

The economizer damper is accompanied by a factory-installed and wired modulating actuator. The damper is factory set at 25% default minimum and 100% maximum opening. The damper is field adjustable using Tracer Summit® or Rover™ to allow a zero to 100% fresh air



# Mechanical Specifications

# Options

### Disconnect Switch

A unit mounted disconnect switch is available as a standard option on all units.

### Colors

Six decorator colors are available in a baked powder finish. For a color chart, contact your local Trane office for a copy of UNT-S-10.

### Extended End Pockets

On vertical or horizontal cabinet units, an 8" (20 cm) extended end pocket is available on the piping end.

### Tamperproof Locks

Key-operated locking access doors and/or panels will help prevent nuisance tampering with unit and/or controls. Tamper proof locks are available on vertical cabinet, horizontal cabinet, vertical recessed, vertical slope top, and low vertical units.

### Leveling Feet

Refrigerator type screw-in bolts to level the unit are available on vertical and low vertical cabinet units.

### Quad Grille Outlet

Quad grilles are square multi-directional grilles that allow four different discharge directions by rotating the grilles 90°. The quad grille construction is a black plastic material (NORYL-SE 1-731) with a 15° angle on the discharge louvers. Quad grilles are recessed into the discharge panel to prevent condensation from forming on the grille exterior. Quad grilles are available on all cabinet style units.



*Quad Grille Outlet*

### Bar Grille Inlet/Outlet

Bar grilles are formed steel grille options available on the discharge of all cabinet units, the return of vertical cabinet, vertical slope tops and low vertical cabinet units. The grilles have a black paint finish with 18-gage steel construction. The louvers are formed at a 15° angle, and the discharge grilles are recessed to prevent condensate formation on the surface of the grille. The bar grilles are fixed in one discharge direction.

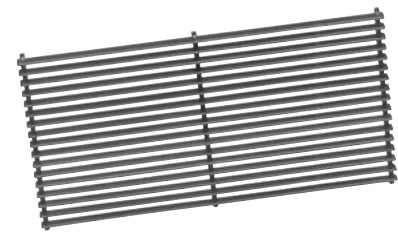

*Bar Grille Inlet and Outlet*

### Sub-bases

Sub-bases elevate vertical cabinet or slope top cabinet units to a specified height; for example, to reach the bottom of a window sill. The sub-base also provides a cavity through which to run piping underneath the fan-coil unit. Sub-bases are 16-gage steel construction and have the same black paint finish as the unit's base. The sub-base is available in heights between 2 - 7" (5 -18 cm) in 1/2" (1 cm) increments. The sub-base depth and width is identical to the unit's dimensions.



*Sub-base (shown turned on its side)*

# Mechanical Specifications

## Options

### False Backs

False backs increase the depth of a vertical cabinet unit and provide a cavity through which to run piping behind the fan-coil unit. False backs are also an excellent application when installing a unit beneath a window sill that extends out past the front of the unit.

False backs are 18-gage steel construction and have the same paint finish as the unit. The false back is available in depths between 2" - 8" (5 - 20 cm) in 1" (2.54 cm) increments, with height and width identical to the unit's dimensions.



*False Back*

### Recessing Flanges

Recessing flanges have 18-gage steel construction and are painted the same finish as the unit. Recessing flanges provide an aesthetic architectural border or frame around vertical and horizontal cabinet fan-coil units.

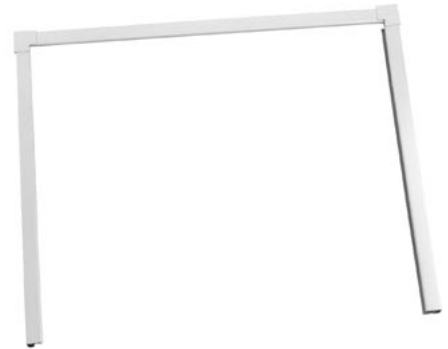

*Recessing Flange*

### Aluminum Wall Boxes

Wall boxes have a clear anodized finish and include a single core wire mesh insect screen. The frame is 10-gage extruded aluminum alloy 6063-T5 construction. Horizontal louvers have 16-gage extruded aluminum alloy 6063-T5 construction.

Wall boxes ship separate for field installation. A field supplied duct or sleeve from the wall box to the unit fresh air opening is required to provide fresh air.

Wall boxes are sized to handle up to 100% of nominal air flow.



*Wall Box*

### Projection Panels

Projection panels allow semi-recessing of vertical recessed units.

Panels are 16-gage steel construction, painted with a baked powder finish. They are available in projection depths ranging from 2" - 6" (5 - 15 cm) in  $\frac{1}{2}$ " (1 cm) increments. There is a distance of  $\frac{7}{8}$ " (2.2 cm) between the projection panel and the front of the unit.

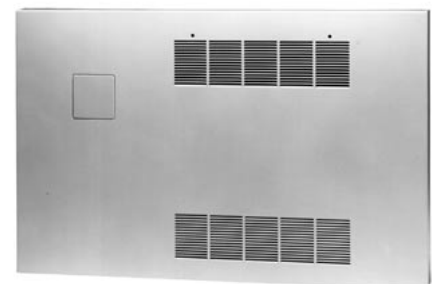

*Projection Panel*

# Mechanical Specifications

# Options



*Ball Valve*

## Piping Components

### Ball Valve

Part	Material	Spec ASTM
Lever	Steel, zinc plated	
Seat	Teflon	VTFE
Packing	Teflon	RTFE
Stem	Rod Brass	B16
G-Nut	Hex Brass	B16
Ball	Brass, chrome plated	B16
Retainer	Brass	B16
Body	Cast Brass	B584-C84400

**Working Pressure**  
400 psi (2,758 kPa)

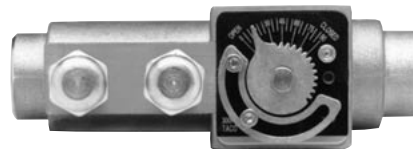

*Manual Circuit Setter*

## Manual Circuit Setter

**Material**  
Body — Forged Brass Alloy  
Trim — Forged Brass Alloy  
All Wetted Parts Brass

**Temperature**  
250°F MAX (121°C)

**Working Pressure**  
300 psi (2,069 kPa)



*Auto Circuit Setter*

## Auto Circuit Setter

**Material**  
Body — Forged Brass  
Flow Cartridge — Electroless Nickel and Stainless Steel

**Temperature**  
250°F MAX (121°C)

**Working Pressure**  
400 psi (2,758 kPa)

**Pressure Drop**  
0.5 - 9.0 gpm = 2 psi ΔP (14 kPa)  
10.0 - 12.0 gpm = 5 psi ΔP (34 kPa)

# Mechanical Specifications

## Options



**Control Valve**

### Control Valve

#### Material

Body — Forged Brass  
 Drive Shaft Stem — Chrome-Plated Brass (Modulating) Brass (2-Position)  
 Seat — Stainless Steel (Modulating)  
 Ball Plug — Buna N Rubber (2-Position)  
 Plug — High Temperature Thermoplastic (Modulating)  
 O-Ring Seals — EPDM Rubber (2-Position)  
 Actuator — Stainless Steel Base Plate, Aluminum Cover

#### Temperature

200°F Max. (94°C)  
 34°F Min. (1°C)

#### Working Pressure

300 psi (2,069 kPa)

#### Pressure Drop (Close-Off $\Delta P$ )\*

2-Way, Two-Position, N.O. = 30 psig (207 kPa)  
 2-Way, Two-Position, N.C. = 30 psig (207 kPa)  
 3-Way, Two-Position, N.O. = 28 psig (193 kPa)  
 3-Way, Two-Position, N.C. = 20 psig (138 kPa)  
 2-Way Modulating = 50 psig (345 kPa)  
 3-Way Modulating = 50 psig (345 kPa)

\*All valves are available with optional 50 psig (345 kPa).

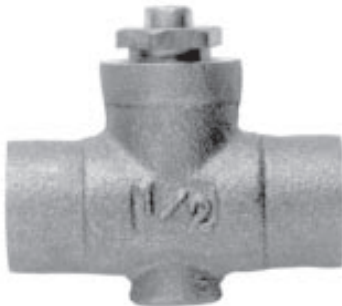

**Balance Fitting**

### Balance Fitting

#### Material

Packing Washer — 11 Ga. Brass  
 O-Ring — EPDM Rubber  
 Stem — Rod Brass  
 Gland Screw — Hex Brass  
 Valve Body — Cast Brass

### Union

#### Material

Nut — Forged Brass  
 Body — Copper  
 Tail — Copper

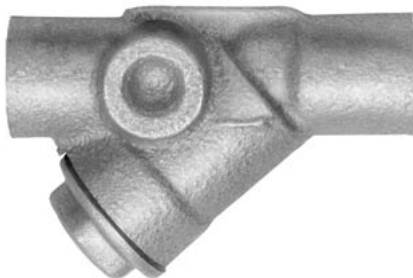

**Strainer**

### Strainer

#### Material

Body — Cast Bronze (85-5-5-5)  
 Cover — Cast Bronze (85-5-5-5)  
 Screen — Stainless Steel (20 Mesh)  
 Gasket — Teflon

#### Pressure and Temperature

400 psi (2,758 kPa) at 150°F (66°C)



# Features and Benefits

## Basic Series

### Basic Series Fan-Coil Sizes 04-08

The basic series fan-coil design is for the market that requires only the *basic* features of our standard UniTrane® fan-coil. Basic series units are horizontal concealed and are available with an exposed fan, plenum, or ceiling access panel.

The basic series unit features include:

- Quality
- Three or four-row coils
- Ship loose ball valves
- Ship loose fan mode switch

#### Quality

Built with the same high quality as the UniTrane®, coils and control end devices

are tested thoroughly before units are shipped.

Coils are air and leak-tested before being mounted in the unit.

All control end devices, fans, and motors are tested on assembled units.

#### Three or four-row coils

Three or four-row coils allow design of two and four-pipe systems.

#### Ship-loose ball valves

Ball valves are ship-loose accessories for field piping.

#### Ship-loose fan mode switch

Control options are simple. Units can be built with either no controls or a wall-mounted fan mode switch.

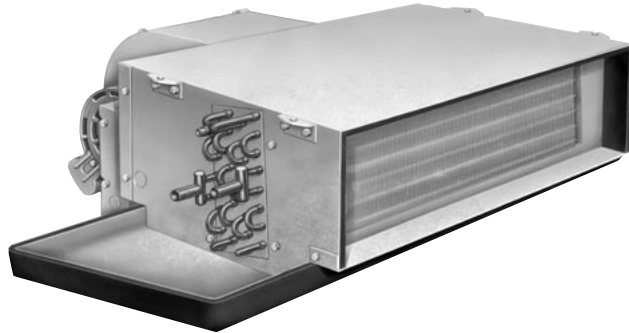



# Selection Procedure

# Basic Series Model Number

## Model Number Description

Following is a complete description of the basic series fan-coil model number. Each digit in the model number has a corresponding alphanumeric code to identify the specific option.

**FC X C 04 B 1 L A0 A F 0 1**  
1                      5                      10                      15

### Digits 1, 2 — Unit Type

FC = Fan-coil

### Digit 3 — Model

X = Exposed fan

P = With plenum

R = With ceiling access panel, ship separate

### Digit 4 — Development Sequence "C"

### Digits 5, 6 — Unit Size

04

06

08

### Digit 7 — Coil

B = 3 row cooling/heating

C = 4 row cooling/heating

D = 2 row cooling/1 row heating

E = 2 row cooling/2 row heating

F = 3 row cooling/1 row heating

L = 3 row cooling; aux. electric heat

M = 4 row cooling; aux. electric heat

### Digit 8 — Unit Voltage

1 = 115/60/1

2 = 208/60/1

4 = 230/60/1

5 = 110-120/50/1

6 = 220-240/50/1

### Digit 9 — Piping Connections

L = Left hand connections

R = Right hand connections

### Digits 10, 11 — Design Sequence "A0"

### Digit 12 — Motor

A = Free discharge

B = High static

### Digit 13 — Control

0 = None

F = Fan speed switch

### Digit 14 — Auxilliary Electric Heat

0 = None

A = 1.0 kW (.75 kW at 208V)

B = 1.5 kW (1.1 kW at 208V)

C = 2.0 kW (1.5 kW at 208V)

D = 2.5 kW (1.9 kW at 208V)

E = 3.0 kW (2.2 kW at 208V)

F = 4.0 kW (3.0 kW at 208V)

G = 5.0 kW (3.8 kW at 208V)

H = 6.0 kW (4.4 kW at 208V)

### Digit 15 — End Valve

0 = None

1 = Ball valve

### Digit 16 — Main Control Valve (Line Voltage Only)

0 = None

A = 2 way, 2 pos. NO

B = 3 way, 2 pos. NO

C = 2 way, 2 pos. NC

D = 3 way, 2 pos. NC



# General Data

# Basic Series

**Table B-GD-1. Coil Data**

Unit Size	04	06	08
Face Area — Ft.	1.1	1.6	2.1
(cm)	(1020)	(1490)	(1950)
LxDxH—In. (cm)			
3-Row	20x2.6x8 (51x7x20)	29.5x2.6x8 (75x7x20)	38x2.6x8 (97x7x20)
4-Row	20x3.5x8 (51x9x20)	29.5x3.5x8 (75x9x20)	38x3.5x8 (97x9x20)
Volume — Gal. (Liters)			
1-Row (4-pipe only)	.08 (.30)	.11 (.42)	.14 (.53)
2-Row (4-pipe only)	.15 (.57)	.22 (.83)	.28 (1.06)
3-Row	.23 (.87)	.33 (1.25)	.42 (1.59)
4-Row	.30 (1.14)	.44 (1.67)	.56 (2.12)
Fins per Ft. (cm)			
All coils	144 (4.7)	144 (4.7)	144 (4.7)

**Table B-GD-2. Fan/Motor Data**

Fan Quantity	1	2	2
Size — Dia" x Width" (cm)	6.31x7.5 (16x19)	6.31x6.5 (16x17)	6.31x7.5 (16x19)
Motor Quantity	1	1	1

**Table B-GD-3. Air Flow**

Unit Size	Motor Coil	ESP				
		FD		High Static		
		0.05	0.1	0.2	0.3	0.4
04	3R144	370	550	510	470	430
	4R144	340	510	480	440	400
06	3R144	610	890	830	770	710
	4R144	560	820	760	710	660
08	3R144	730	1000	930	870	800
	4R144	680	940	870	810	750



# Performance Data

# Basic Series Sizes 04-08

ARI cooling performance is based on 80/67°F (27/19°C) entering air temperature, 45°F (7°C) entering chilled water temperature with a 10°F (5.5°C) ΔT. Heating performance is based on 70°F (21°C) entering air temperature, 180°F (82°C) entering hot water temperature with a 30°F (17°C) ΔT. All performance measured on high speed tap, free discharge motor at zero ESP, high static motor at 0.2 ESP, with throwaway filter, and is valid for all voltages except 208.

**Table B-PD-1. Free Discharge Motor, Two-Pipe**

FC	Coil	Cooling					Heating					115V Watt	230V Watt	277V Watt
		Cfm (L/s)	TMBh (TkW)	SMBh (SkW)	Gpm (L/s)	WPD (kPa)	TMBh (TkW)	Q/ITD	Gpm (L/s)	WPD (kPa)				
4	3CH	374 (177)	11.5 (3.4)	8.1 (2.4)	2.37 (.15)	9.5 (28.3)	31.8 (9.3)	0.29	2.12 (.13)	6.4 (19.0)	100	107	106	
	4CH	350 (165)	13.0 (3.8)	8.7 (2.5)	2.66 (.17)	14.8 (44.4)	34.2 (10.0)	0.31	2.28 (.14)	9.1 (27.3)	100	107	106	
6	3CH	608 (287)	16.6 (4.9)	12.4 (3.6)	3.40 (.21)	4.9 (14.8)	49.7 (14.6)	0.45	3.31 (.21)	4.2 (12.6)	125	130	124	
	4CH	565 (267)	19.4 (5.7)	13.3 (3.9)	3.96 (.25)	7.8 (23.2)	53.8 (15.8)	0.49	3.59 (.23)	5.7 (17.0)	125	130	124	
8	3CH	731 (345)	20.6 (6.1)	14.7 (4.3)	4.21 (.27)	8.2 (24.4)	61.6 (18.1)	0.56	4.11 (.26)	6.9 (20.7)	120	123	133	
	4CH	688 (325)	22.8 (6.7)	15.5 (4.5)	4.65 (.29)	11.7 (35.0)	66.8 (19.6)	0.61	4.45 (.28)	9.4 (28.1)	120	123	133	

**Table B-PD-2. High Static Motor, Two-Pipe**

FC	Coil	Cooling					Heating					115V Watt	230V Watt	277V Watt
		Cfm (L/s)	TMBh (TkW)	SMBh (SkW)	Gpm (L/s)	WPD (kPa)	TMBh (TkW)	Q/ITD	Gpm (L/s)	WPD (kPa)				
4	3CH	484 (228)	14.0 (4.1)	10.2 (3.0)	2.94 (0.19)	13.9 (41.5)	38.6 (11.3)	.35	2.57 (0.16)	9.1 (27.0)	210	210	210	
	4CH	453 (214)	16.0 (4.7)	11.0 (3.2)	3.35 (0.21)	22.3 (66.7)	42.2 (12.4)	.38	2.81 (0.18)	13.4 (39.9)	210	210	210	
6	3CH	780 (368)	20.1 (5.9)	15.5 (4.5)	4.24 (0.27)	7.5 (22.3)	59.5 (17.4)	.54	3.96 (0.25)	5.9 (17.7)	320	320	320	
	4CH	725 (342)	23.9 (7.0)	16.8 (4.9)	4.99 (0.31)	11.9 (35.6)	65.6 (19.2)	.60	4.37 (0.28)	8.2 (24.6)	320	320	320	
8	3CH	886 (418)	24.6 (7.2)	17.9 (5.3)	5.13 (0.32)	11.8 (35.2)	71.2 (20.9)	.65	4.74 (0.30)	9.1 (27.1)	320	320	320	
	4CH	835 (394)	27.3 (8.0)	18.9 (5.5)	5.68 (0.36)	16.9 (50.6)	78.3 (22.9)	.71	5.22 (0.33)	12.7 (37.8)	320	320	320	

Note:

1. Cfm = Cubic feet per minute
2. TMBh = Total capacity (MBh)
3. Gpm = Gallons per minute
4. WPD = Water pressure drop (feet of water)
5. Q/ITD = MBh (kW)/(entering water temperature - entering air temperature) when ΔT and gpm (L/s) remain constant. To determine heating capacities at a different entering water temperature or entering air temp, compute the new ITD and multiply it by the Q/ITD shown.
6. Medium and low speed capacities are approximately 80% and 60% respectively of the high speed capacity.



# Performance Data

# Basic Series Sizes 04-08

ARI cooling performance is based on 80/67°F (27/19°C) entering air temperature, 45°F (7°C) entering chilled water temperature with a 10°F (5.5°C) ΔT. Heating performance is based on 70°F (21°C) entering air temperature, 180°F (82°C) entering hot water temperature with a 30°F (17°C) ΔT. All performance measured on high speed tap, free discharge motor at zero ESP, high static motor at 0.2 ESP, with throwaway filter, and is valid for all voltages except 208.

**Table B-PD-3. Free Discharge Motor, Four-Pipe**

FC	Coil	Cooling					Heating					115V Watt	230V Watt	277V Watt
		Cfm (L/s)	TMBh (TkW)	SMBh (SkW)	Gpm (L/s)	WPD (kPa)	TMBh (TkW)	Q/ITD	Gpm (L/s)	WPD (kPa)				
4	2C1H	374 (177)	8.4 (2.5)	6.6 (2.0)	1.74 (0.11)	3.9 (11.7)	15.0 (4.4)	.14	1.00 (0.06)	2.8 (8.4)	100	107	106	
	2C2H	350 (165)	8.0 (2.4)	6.4 (1.9)	1.67 (0.11)	3.7 (11.0)	23.8 (7.0)	.22	1.59 (0.10)	2.8 (8.3)	100	107	106	
	3C1H	350 (165)	11.1 (3.3)	7.8 (2.3)	2.28 (0.14)	8.9 (26.5)	14.4 (4.2)	.13	0.96 (0.06)	2.6 (7.8)	100	107	106	
6	2C1H	608 (287)	14.7 (4.3)	11.1 (3.2)	3.01 (0.19)	12.8 (38.4)	24.2 (7.1)	.22	1.61 (0.10)	8.4 (25.2)	125	130	124	
	2C2H	565 (267)	14.1 (4.1)	10.6 (3.1)	2.91 (0.18)	12.0 (36.0)	38.4 (11.3)	.35	2.56 (0.16)	8.0 (23.9)	125	130	124	
	3C1H	565 (267)	15.9 (4.7)	11.8 (3.5)	3.26 (0.21)	4.6 (13.7)	23.1 (6.8)	.21	1.54 (0.10)	7.8 (23.3)	125	130	124	
8	2C1H	731 (345)	15.4 (4.5)	12.5 (3.7)	3.16 (0.20)	3.8 (11.4)	30.2 (8.9)	.27	2.01 (0.13)	15.1 (45.1)	120	123	133	
	2C2H	688 (325)	14.8 (4.4)	12.0 (3.5)	3.05 (0.19)	3.6 (10.7)	46.2 (13.5)	.42	3.08 (0.19)	3.3 (9.9)	120	123	133	
	3C1H	688 (325)	20.0 (5.9)	14.2 (4.2)	4.08 (0.26)	7.7 (23.0)	29.1 (8.5)	.26	1.94 (0.12)	14.1 (42.1)	120	123	133	

**Table B-PD-4. High Static Motor, Four-Pipe**

FC	Coil	Cooling					Heating					115V Watt	230V Watt	277V Watt
		Cfm (L/s)	TMBh (TkW)	SMBh (SkW)	Gpm (L/s)	WPD (kPa)	TMBh (TkW)	Q/ITD	Gpm (L/s)	WPD (kPa)				
4	2C1H	484 (228)	9.9 (2.9)	8.1 (2.4)	2.13 (0.13)	5.6 (16.9)	17.5 (5.1)	.16	1.17 (0.07)	3.7 (11.1)	210	210	210	
	2C2H	453 (214)	9.6 (2.8)	7.8 (2.3)	2.06 (0.13)	5.3 (15.9)	28.4 (8.3)	.26	1.90 (0.12)	3.9 (11.6)	210	210	210	
	3C1H	453 (214)	13.5 (4.0)	9.7 (2.9)	2.84 (0.18)	13.0 (39.9)	16.9 (4.9)	.15	1.12 (0.07)	3.5 (10.3)	210	210	210	
6	2C1H	780 (368)	17.0 (5.0)	13.3 (4.0)	3.62 (0.23)	17.9 (53.4)	27.9 (8.2)	.25	1.86 (0.12)	10.9 (32.6)	320	320	320	
	2C2H	725 (342)	16.4 (4.8)	12.7 (3.7)	3.50 (0.22)	16.8 (50.1)	45.4 (13.3)	.41	3.03 (0.19)	10.9 (32.6)	320	320	320	
	3C1H	725 (342)	19.3 (5.7)	14.7 (4.3)	4.08 (0.26)	6.9 (20.7)	26.8 (7.9)	.24	1.79 (0.11)	10.1 (30.3)	320	320	320	
8	2C1H	886 (418)	18.1 (5.3)	15.0 (4.4)	3.85 (0.24)	5.5 (16.5)	34.0 (10.0)	.31	2.26 (0.14)	18.6 (55.5)	320	320	320	
	2C2H	835 (394)	17.6 (5.1)	14.4 (4.2)	3.73 (0.24)	5.2 (15.5)	52.8 (15.5)	.48	3.52 (0.22)	4.3 (12.8)	320	320	320	
	3C1H	835 (394)	23.8 (7.0)	17.3 (5.1)	4.98 (0.31)	11.1 (33.3)	32.8 (9.6)	.30	2.19 (0.14)	17.5 (52.2)	320	320	320	

- Note:
1. Cfm = Cubic feet per minute
  2. TMBh = Total capacity (MBh)
  3. Gpm = Gallons per minute
  4. WPD = Water pressure drop (feet of water)
  5. Q/ITD = MBh (kW)/(entering water temperature - entering air temperature) when ΔT and gpm (L/s) remain constant. To determine heating capacities at a different entering water temperature or entering air temp, compute the new ITD and multiply it by the Q/ITD shown.
  6. Medium and low speed capacities are approximately 80% and 60% respectively of the high speed capacity.

## Basic Series Accessories

### Controls



*Wall-mounted fan mode switch*

#### Manual Three-Speed Fan Switch

The manual three-speed fan switch is a simple four-position switch (OFF-HI-MED-LO) which allows fan mode selection.

The fan switch is wall-mounted and controls the fan motor by line voltage.

Off: Fan is turned off.

Hi, Med, Lo: Fan runs continuously at the selected speed setting.



*Ball valves are a ship-loose accessory.*

#### Ball Valves

Ball valves are available as ship-loose components with each unit:

Ball valves, also known as stop or end valves, allow waterflow into the unit to be cut off for service purposes. These valves have a two-inch handle that rotates 90° to a fully open position. The valve body is cast brass, the ball is chrome plated brass, and the seat is Teflon™. Ball valves are available as end valves for both the entering and leaving water pipe of field-installed piping. Working pressure is 400 psi (2,758 kPa).

#### Ball Valve Material

Part	Material	Spec ASTM
Lever	Steel, zinc plated w/vinyl	
Seat	Teflon	VTFE
Stem Packing	Teflon	RTFE
Stem	Rod Brass	B16
G-Nut	Hex Brass	B16
Ball	Brass, chrome plated	B16
Retainer	Brass	B16
Body	Cast Brass	B584-C84



# Electrical Data Basic Series

## Electric Heat

Basic series fan-coils with inlet plenums are available with electric heating coils.

### Coil Construction and Location

Electric heat coils are open wire type with a nickel chromium element design. All coils are located in the preheat position.

### Power Supply

Units have single-point power since the electric heating elements operate on line voltage.

## Electric Heat Features

- All basic series fan-coil units are UL approved.
- Units require only a single-point electrical connection.
- A unit mounted magnetic contactor(s) is (are) supplied on all unit voltages.
- A high temperature cutout with automatic reset de-energizes the electric heat in the event of an overheat condition.
- When hydronic heating is active, a lockout sensor will disable the electric heat.

**Table B-ED-1. Electric Heat kW**

Unit Size	Unit Voltage	kW	kW	kW	kW	kW	kW	kW	kW
04	115	1.0	1.5	2.0	2.5				
	230	1.0	1.5	2.0	2.5				
	208	0.75	1.1	1.5	1.9				
06	115			2.0		3.0			
	230			2.0		3.0	4.0	5.0	
	208			1.5		2.2	3.0	3.8	
08	115			2.0		3.0			
	230			2.0		3.0	4.0	5.0	6.0
	208			1.5		2.2	3.0	3.8	4.4

## Minimum Circuit Ampacity (MCA) and Maximum Fuse Size (MFS) Calculations for Fan-Coils with Electric Heat:

$$\text{Heater Amps} = (\text{Heater kW} \times 1000) / \text{Heater Voltage}$$

*Note: Use 120V heater voltage for 115V units. Use 240V heater voltage for 230V units.*

$$\text{MCA} = 1.25 \times (\text{heater amps} + \text{all motor FLA's})$$

$$\text{MFS or HACR Type Circuit Breaker} = (2.25 \times \text{Largest Motor FLA}) + \text{Second Motor FLA} + \text{Heater Amps}$$

HACR (Heating, Air-Conditioning and Refrigeration) type circuit breakers are required in the branch circuit wiring for all fan-coils with electric heat. See the Electrical Data section for motor FLA's.

*Note: Select a standard fuse size or HACR type circuit breaker equal to the MCA. Use the next larger standard size if the MCA does not equal a standard size. Standard fuse sizes are: 15, 20, 25, 30, 35, 40, 45, 50, and 60 amps*

$$\text{Fan-coil electric heat MBh} = (\text{heater kW}) (3.413)$$



# Electrical Data Basic Series

**Table B-ED-2. Three and Four-Row Coils — Free Discharge Motors**

FC	115 Volt		208 Volt		RPM		
	FLA	HP (kW)	FLA	HP (kW)	H	M	L
04	1.0	.06 (.04)	0.6	.06 (.04)	108	800	600
06	1.4	.12 (.09)	0.9	.12 (.09)	108	800	600
08	1.7	.13 (.10)	1.0	.13 (.10)	108	800	600

**Table B-ED-3. Three and Four-Row Coils — High Static Motors**

FC	115 Volt		208 Volt		RPM		
	FLA	HP (kW)	FLA	HP (kW)	H	M	L
04	2.1	.13 (.10)	0.9	.13 (.10)	1580	1375	1240
06	3.4	.24 (.18)	1.4	.24 (.18)	1475	1285	975
08	3.4	.24 (.18)	1.4	.24 (.18)	1475	1285	975

Note: Actual RPM will vary with application and configuration.

**Table B-ED.4. Decimal to Fractional HP (kW) Conversion**

Unit Size	Decimal	Fraction
04	.04	1/25
	.06	1/16
	.10	1/10
	.13	1/8
06	.09	1/11
	.12	1/8
	.18	1/6
	.24	1/4
08	.10	1/10
	.13	1/8
	.18	1/6
	.24	1/4

**Minimum Circuit Ampacity (MCA) and Maximum Fuse Size (MFS) Calculations for fan-coils: (Motors only)**

MCA = (1.25) × [Largest Motor Amperes (FLA)]

MFS or Heating, Air-Conditioning, and Refrigeration (HACR) Type Circuit Breaker = 15 amps for all fan-coils without electric heat



# Dimensions and Weights

# Basic Series Exposed Fan

## Basic Unit With Exposed Fan, Model X

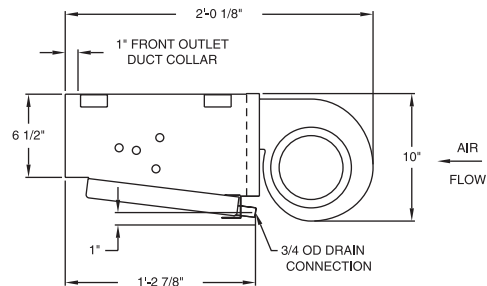
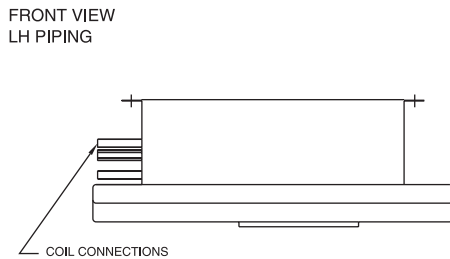
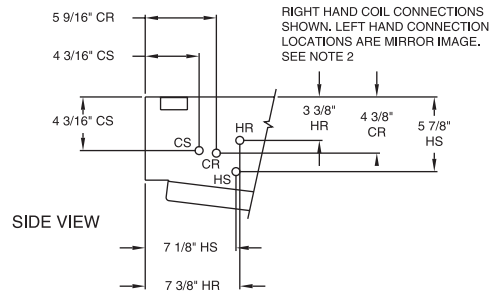
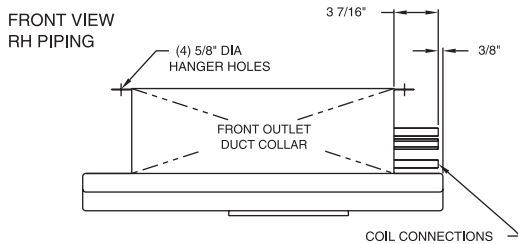
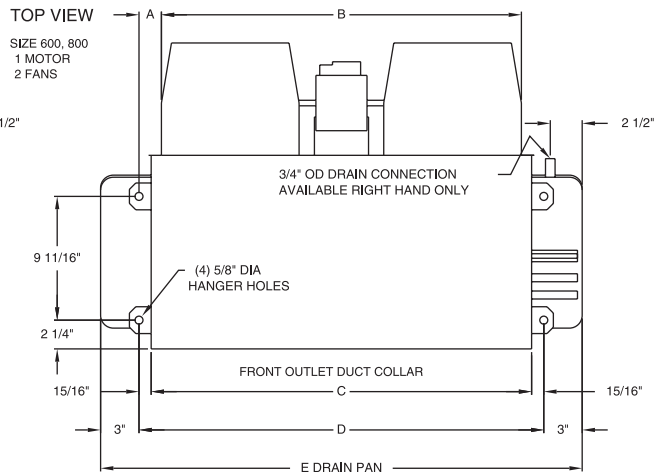
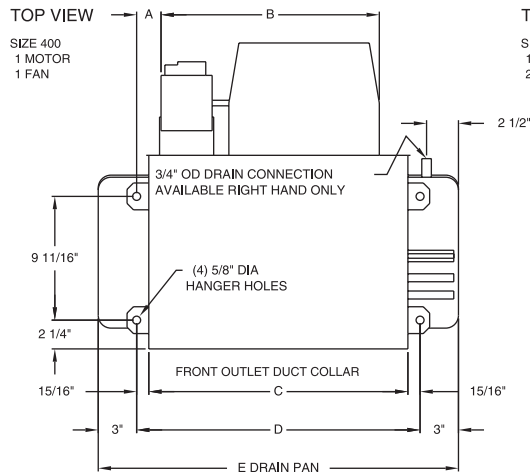

Unit Size	04	06	08
A	1 15/16"	1 3/4"	5 "
B	1'-5 1/16"	2'-4 3/16"	2'-6 3/16"
C	1'-8 5/16"	2'-5 13/16"	3'-2 5/16"
D	1'-10 3/16"	2'-7 11/16"	3'-4 3/16"
E	2'-4 3/16"	3'-1 11/16"	3'-10 3/16"
Shipping Wgt., lbs	96	123	131
Operating Wgt., lbs	109	139	147

- Note:
- The condensate drain connection is always on the right hand side of the unit as shown.
  - Coil connections are 5/8" OD sweat.  
CS - Cooling coil supply  
CR - Cooling coil return  
HS - Heating coil supply  
HR - Heating coil return
  - All duct collar dimensions are to the outside of the collar.

# Dimensions and Weights

# Basic Series With Plenum

## Basic Unit With Plenum, Model P

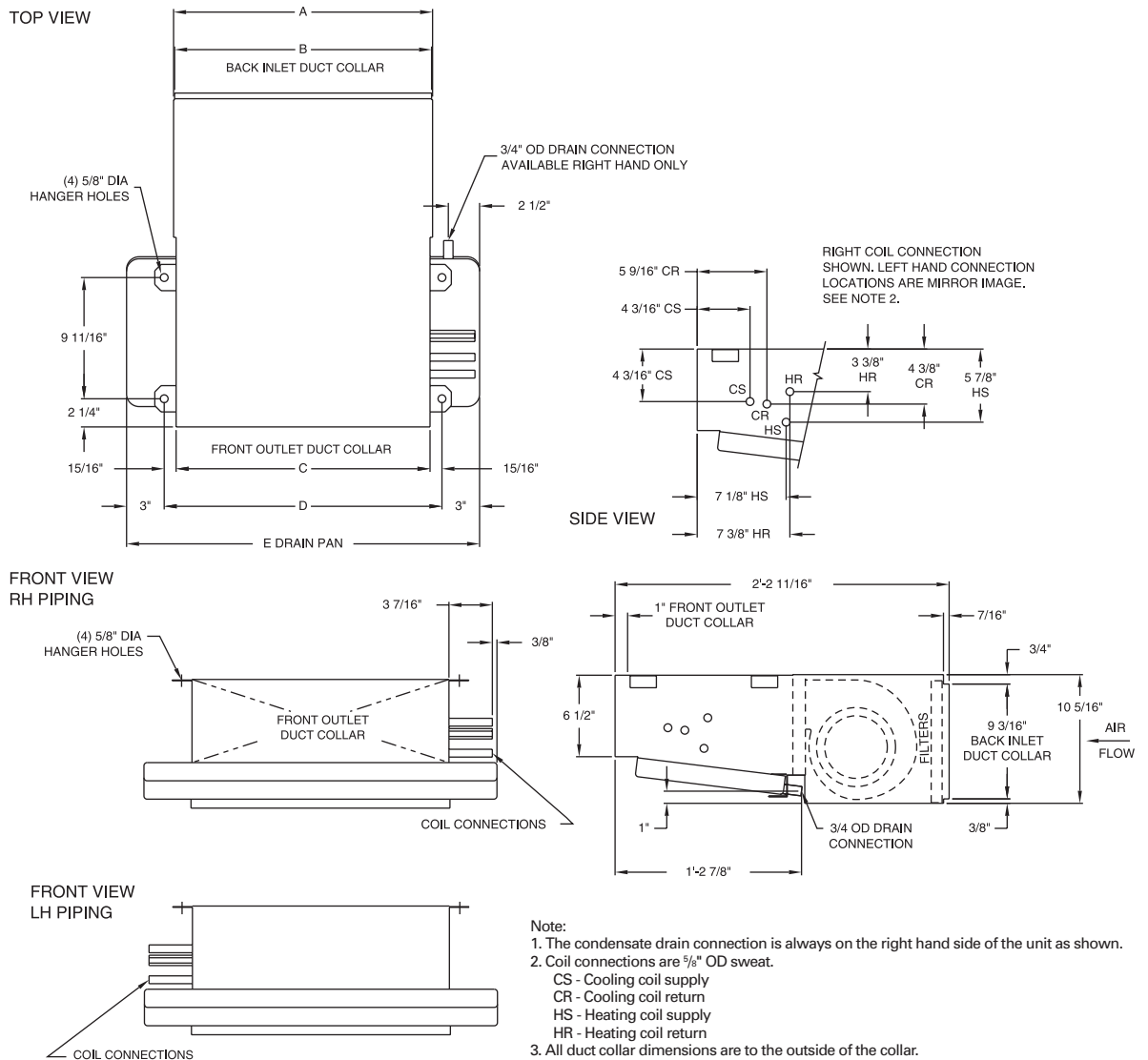

Unit Size	04	06	08
A	1'-8 11/16"	2'-6 3/16"	3'-2 11/16"
B	1'-8 1/2"	2'-6"	3'-2 1/2"
C	1'-8 5/16"	2'-5 13/16"	3'-2 5/16"
D	1'-10 3/16"	2'-7 11/16"	3'-4 3/16"
E	2'-4 1/4"	3'-1 3/4"	3'-10 1/4"
Shipping Wgt., lbs	107	138	149
Operating Wgt., lbs	120	154	165



# Dimensions and Weights

# Basic Series With Ceiling Panel

## Basic Unit With Ceiling Access Panel, Model R

Unit Size	04	06	08
A	3'-1 <sup>7</sup> / <sub>16</sub> "	3'-10 <sup>15</sup> / <sub>16</sub> "	4'-7 <sup>7</sup> / <sub>16</sub> "
B	3'-3 <sup>5</sup> / <sub>16</sub> "	4'-0 <sup>13</sup> / <sub>16</sub> "	4'-9 <sup>5</sup> / <sub>16</sub> "
C	3'-4 <sup>13</sup> / <sub>16</sub> "	4'-2 <sup>5</sup> / <sub>16</sub> "	4'-10 <sup>13</sup> / <sub>16</sub> "
Shipping Wgt, lbs	114	123	131
Operating Wgt, lbs	127	161	181

TOP VIEW

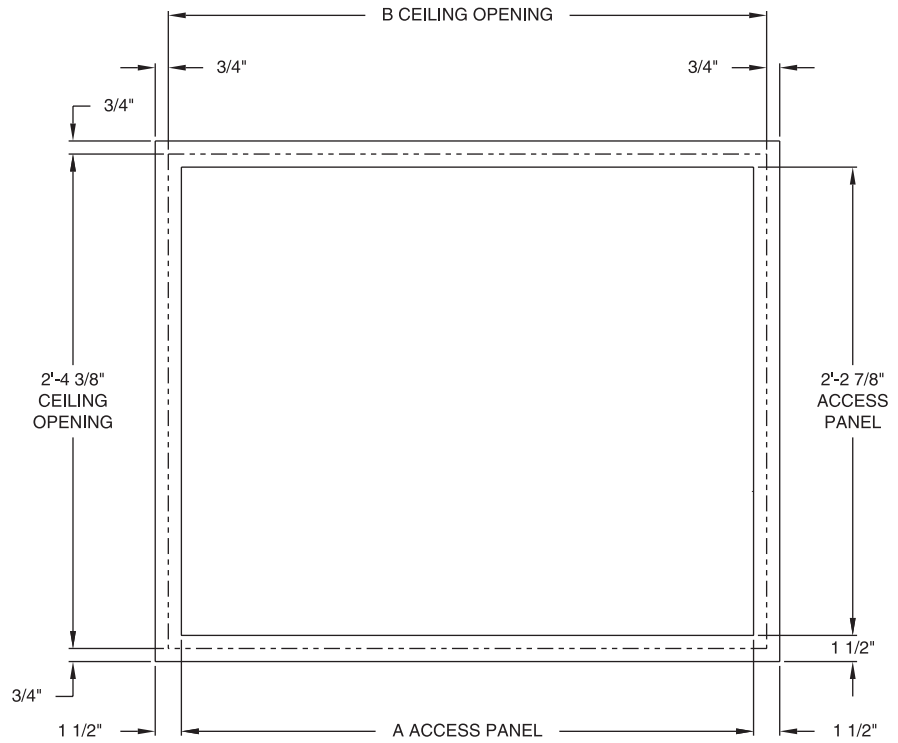

FRONT VIEW

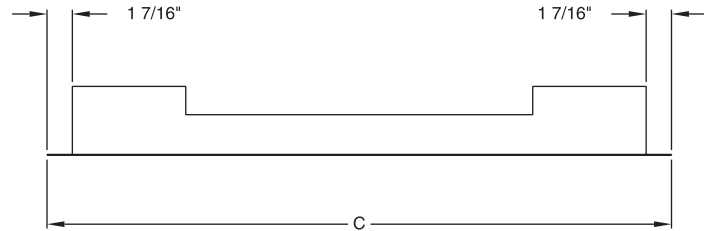

SIDE VIEW

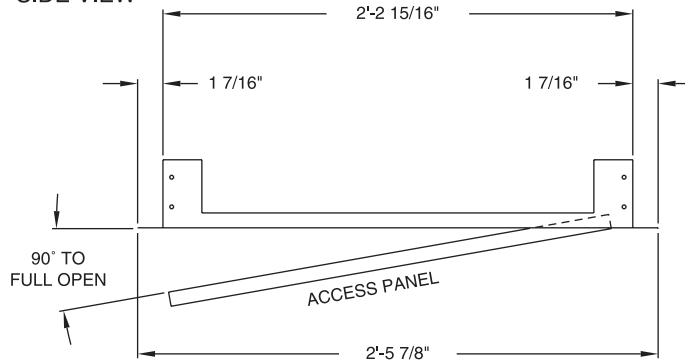

# Mechanical Specifications

## Basic Series

### Basic Series Fan-Coil Mechanical Specifications

#### Capacity

Unit capacities are certified under Industry Room Fan-Coil Air Conditioner Certification Program in accordance with ARI Standard 440-97.

#### Safety

All basic series units are UL listed.

#### Construction

The basic series unit includes a chassis, coil, fan wheel(s), fan board, and motor. Units also include a sloped, galvanized main drain pan. Steel parts exposed to moisture are galvanized. The chassis construction is 18-gage galvanized steel, and is continuous throughout the unit. The unit is insulated with closed-cell insulation.

#### Ceiling Access Panel

The ceiling access panel fabrication is 18-gage steel and ships separate from the unit. Also, the ceiling access panel includes tamperproof screw fasteners and a safety chain. Panels are made rigid by channel forming. All ceiling access panels are cleaned, bonderized, and painted with deluxe beige baked powder finish. Standard finish meets ASTM B117 specifications (salt spray test).

#### Inlet Plenum

The inlet plenum construction is 18-gage galvanized steel. It includes a 1" (25 mm) throwaway filter.

#### Fan

The aluminum fan wheels are centrifugal forward-curved and double-width. Fan wheels and housings are corrosion resistant. Fan housings construction is formed sheet metal.

#### Motor

The motor has a permanent split capacitor, integral thermal overload protection,

and is permanently lubricated. It is capable of starting at 78% of rated voltage and operating at 90% of rated voltage on all speed settings. The motor is run tested in assembled units.

#### Coil

All water coils are burst tested at 450 psig (3,103 kPa) (air) and leak tested at 100 psig (690 kPa) (air under water). Maximum main coil working pressure is 300 psig (2,069 kPa). Maximum entering water temperature is 200°F (93°C). Tubes and u-bends are  $\frac{3}{8}$ " (10 mm) OD copper. Fins are aluminum and are mechanically bonded to the copper tubes. Coil stubouts are  $\frac{5}{8}$ " (16 mm) OD copper tubing. All coils include a manual air vent.

#### Ball Valve

A ball-type stop valve is available for field-installation on both the entering and leaving water pipe. The ball valve is a shutoff valve with a maximum working pressure of 400 psig (2,758 kPa).

#### Electric Heat Coil

The auxiliary electric heating coil is provided as either the total source of heat or auxiliary intermediate season heating. The electric heat coils are located in the preheat position, and are the open-wire type. The coils are a nickel chromium element design. The electric heat operates at the same voltage as the unit, and only a single power connection is necessary. All standard electric heat coils are UL listed. A unit-mounted magnetic contactor is supplied on all voltages. A high temperature cutout with automatic reset is provided as an integral part of the elements to de-energize the electric heat in the event of an overheat condition.



**TRANE®**

**A Division of American Standard Inc.**  
**[www.trane.com](http://www.trane.com)**

*For more information contact  
your local Trane office or  
e-mail [comfort@trane.com](mailto:comfort@trane.com)*

---

Literature Order Number	UNT-PRC001-EN
File Number	PL-TD-UNT-PRC001-EN-0302
Supersedes	UNT-PRC001-EN 12/00
Stocking Location	La Crosse - Inland Printing

Trane has a policy of continuous product improvement and reserves the right to change design and specifications without notice.